

Model GX-2001

Operator's Manual

Part Number: 71-0053RK

Revision: J

Released: 10/21/10

WARNING

Read and understand this instruction manual before operating instrument. Improper use of the gas monitor could result in bodily harm or death.

Periodic calibration and maintenance of the gas monitor is essential for proper operation and correct readings. Please calibrate and maintain this instrument regularly!

Frequency of calibration depends upon the type of use you have and the sensor types.

Typical calibration frequencies for most applications are between 1 and 3 months, but can be required more often or less often based on your usage.

Warranty

RKI Instruments, Inc., warrants the Model GX-2001 sold by us to be free from defects in materials, workmanship, and performance for a period of two years from the date of shipment from RKI Instruments, Inc. This includes the instrument and the original sensors. Replacement parts are warranted for 1 year from the date of their shipment from RKI Instruments, Inc. Any parts found defective within their warranty period will be repaired or replaced, at our option, free of charge. This warranty does not apply to those items which by their nature are subject to deterioration or consumption in normal service, and which must be cleaned, repaired, or replaced on a routine basis. Examples of such items are:

Absorbent cartridges

Filter elements, disks, or sheets

Pump diaphragms and valves

Warranty is voided by abuse including mechanical damage, alteration, rough handling, or repair procedures not in accordance with the instruction manual. This warranty indicates the full extent of our liability, and we are not responsible for removal or replacement costs, local repair costs, transportation costs, or contingent expenses incurred without our prior approval.

THIS WARRANTY IS EXPRESSLY IN LIEU OF ANY AND ALL OTHER WARRANTIES AND REPRESENTATIONS, EXPRESSED OR IMPLIED, AND ALL OTHER OBLIGATIONS OR LIABILITIES ON THE PART OF RKI INSTRUMENTS, INC., INCLUDING BUT NOT LIMITED TO THE WARRANTY OF MERCHANTABILITY OR FITNESS FOR A PARTICULAR PURPOSE. IN NO EVENT SHALL RKI INSTRUMENTS, INC., BE LIABLE FOR INDIRECT, INCIDENTAL, OR CONSEQUENTIAL LOSS OR DAMAGE OF ANY KIND CONNECTED WITH THE USE OF ITS PRODUCTS OR FAILURE OF ITS PRODUCTS TO FUNCTION OR OPERATE PROPERLY.

This warranty covers instruments and parts sold to users only by authorized distributors, dealers, and representatives as appointed by RKI Instruments, Inc.

We do not assume indemnification for any accident or damage caused by the operation of this gas monitor and our warranty is limited to replacement of parts or our complete goods.

Table of Contents

Introduction	1
Specifications	2
Description	4
Case	4
Sensors	5
Scrubber Filters/Sensor Cover	6
LCD	7
Control Buttons	7
Printed Circuit Boards	8
Alarm Lights	8
Buzzer/Vibrator	9
Battery Pack	9
Belt Clip	9
Battery Charger	9
Start Up	10
Start-up Procedure	10
Performing a Demand Zero	11
Turning Off the Model GX-2001	11
Operation	12
Normal Operation	12
Displaying Peak Readings	12
Displaying STEL and TWA Readings	13
Combustible Gas Detection	14
Alarms	15
Aspirator Adapter	19
Displaying and Setting the Alarm Points	21
Setting the Time and Date	23

Calibration	24
Setting the Zero Readings for All Target Gasses	24
Single Calibration	25
Auto Calibration	28
Maintenance	30
Troubleshooting	30
Recharging the Battery Pack	32
Replacing the Battery Pack	33
Replacing the Scrubber Filters	35
Replacing the Sensor Cover	36
Replacing a Sensor	37
Rotating the Belt Clip	38
Parts List	39

WARNING: Understand manual before operating. Substitution of components may impair intrinsic safety. To prevent ignition of a hazardous atmosphere, batteries must only be changed or charged in an area known to be nonhazardous. Not tested in oxygen enriched atmospheres (above 21%).

Introduction

Using an advanced detection system consisting of four gas sensors, the Model GX-2001 Personal Four-Gas Monitor detects the presence of combustible gas, oxygen (O₂), carbon monoxide (CO), and hydrogen sulfide (H₂S) simultaneously. The Model GX-2001's compact size and easy-to-use design makes it ideally suited for a wide range of applications, including sewage treatment plants, utility manholes, tunnels, hazardous waste sites, power stations, petrochemical refineries, mines, paper mills, drilling rigs, and fire fighting stations. The Model GX-2001 offers a full range of features, including:

- Simultaneous four-gas monitoring of combustible gases, O₂, CO, and H₂S
- Liquid crystal display (LCD) for complete and understandable information at a glance
- Distinctive audible/vibrating alarms for dangerous gas conditions and audible alarms for unit malfunction
- Glow in the dark control buttons.
- Microprocessor control for reliability, ease of use, and advanced capabilities
- Alarm trend data
- Data logging functions
- STEL/TWA and over range alarm display
- Peak hold and average readouts
- Built-in time function
- RF shielded and high impact plastic case of very compact size and light weight
- Belt clip for "hands-free" gas monitoring
- CSA classified for Class I, Division I, Groups A, B, C, and D hazardous atmospheres

WARNING: The Model GX-2001 detects oxygen deficiency and elevated levels of oxygen, combustible gases, carbon monoxide, and hydrogen sulfide, all of which can be dangerous or life threatening. When using the Model GX-2001, you must follow the instructions and warnings in this manual to assure proper and safe operation of the unit and to minimize the risk of personal injury. Be sure to maintain and periodically calibrate the GX-2001 as described in this manual.

Specifications

Table 1: Model GX-2001 Specifications

Model Name	Model GX-2001			
Target Gas	Combustibles (Methane calibration standard)	Oxygen (O ₂)	Hydrogen Sulfide (H ₂ S)	Carbon Monoxide (CO)
Range (Increment)	0-100% LEL (1% LEL)	0-40.0 vol% (0.1 vol%)	0-100 ppm (0.5 ppm)	0-500 ppm (1 ppm)
Detection Method	Diffusion			
Response Time	T90 Within 30 Seconds			
Display	7-Segment Digital LCD			
Gas Alarms (Factory Settings)	Alarm 1: 10% LEL Alarm 2: 50% LEL Over: 100% LEL	Alarm 1: 19.5 vol% (Decreasing) Alarm 2: 23.5 vol% Over: 40.0 vol%	Alarm 1: 10 ppm Alarm 2: 30 ppm TWA: 10 ppm STEL: 15 ppm	Alarm 1: 25 ppm Alarm 2: 50 ppm TWA: 25 ppm STEL: 200 ppm
Operating Temperature and Humidity	-10 to 40° C/Below 85% RH (Without Condensation)			
Safety/Regulatory	 CSA classified, "C/US", as Intrinsically Safe. Exia. Class I, Groups A, B, C, &D. Class I, Zone 0, Group IIC. Temperature Code T3C.			
Power Supply	Ni-cad or Ni-MH Battery Pack (2.4 VDC Nominal), Direct Charging			
Continuous Operating Hours	Up to 10 Hours (Non Alarm Operation After Full Charge), Ni-Cad Up to 18 Hours (Non Alarm Operation After Full Charge), Ni-MH			
Case	High-impact Plastic, RF Shielded, Dust and Weather Proof			
Required Accessories	Charger Station or Charger/Downloading Station w/Software & Cable			

Table 1: Model GX-2001 Specifications

Model Name	Model GX-2001
Other Accessories	<ul style="list-style-type: none">• Charging Station with PC Communication Function for Datalog Downloading• Communication Computer Cable• Communication Software (Windows® 95, 98, NT)• Automatic Calibration Station• Hand Aspirated Sample Draw with Hose and Probe• Wrist Strap (included with every unit)• Neck Strap
Dimensions and Weight	Dimensions: 2.8 (H), 2.2 (W), 1.1 (D) inches Weight: Approximately 6 oz.

Description

This section describes the components of the Model GX-2001. These components include the Model GX-2001's case, sensors, LCD, control buttons, printed circuit boards, alarm lights, buzzer/vibrator, battery pack, belt clip, and battery charger.

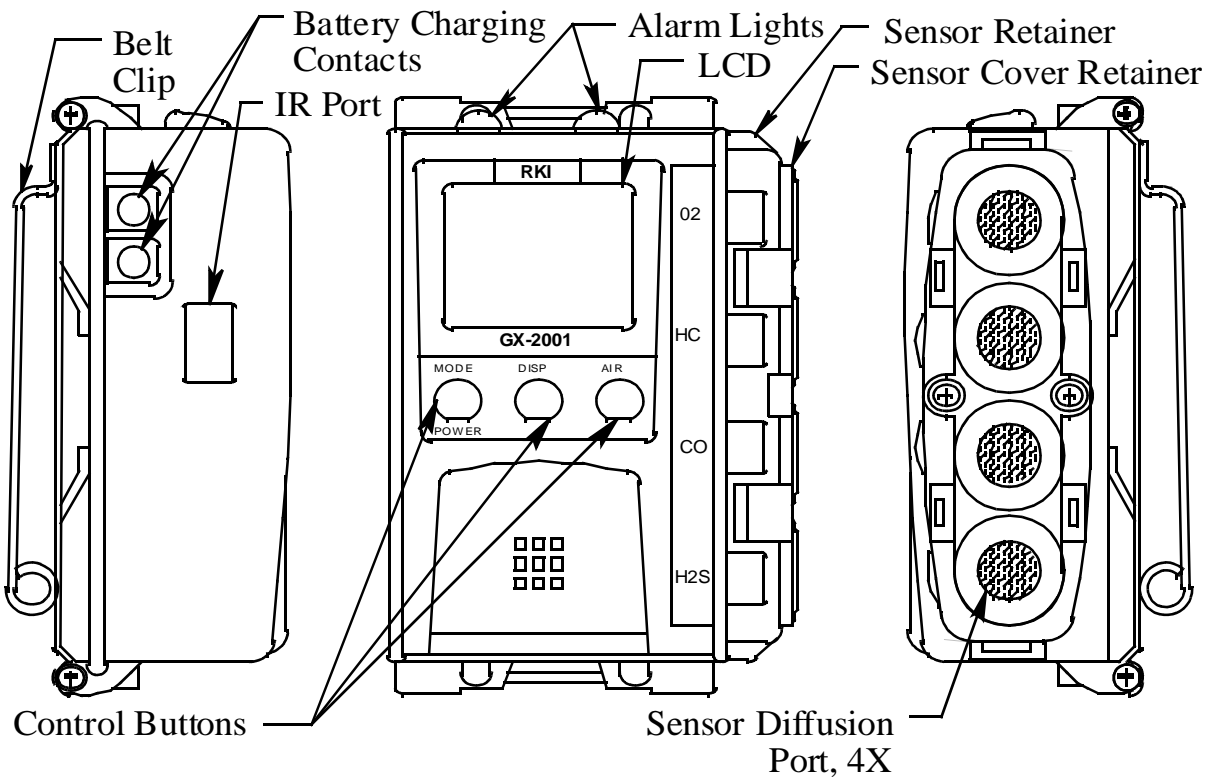

Figure 1: Components of the Model GX-2001

Case

The Model GX-2001's sturdy, high-impact plastic and metal case is radio frequency (RF) resistant, and is suitable for use in many environmental conditions, indoors and out. The unit is dust proof and weather resistant.

On the front of the case is a digital LCD, which shows gas concentrations, battery level, time, and other readings including TWA, STEL, and peak gas levels. Below the LCD are three glow in the dark control buttons. The first button on the left is labeled MODE/POWER. The other buttons are labeled DISP and AIR, respectively.

Beneath the control buttons is the buzzer/vibrator, which is located inside the unit.

On the right side of the Model GX-2001 are the diffusion ports for the gas sensors located inside the case. These sensors are, from top to bottom (and are marked on the case), O₂, HC (combustible gases), CO, and H₂S.

On the left side of the case are two brass recharging contacts, which are used when the unit is placed in the battery charger, and on top of the case are two alarm lights. There is also an IR (infrared) communications port on the left side which is used when downloading data to a computer using the datalogging station. On the back of the unit is a rugged metal belt clip enabling hands-free gas monitoring. The belt clip may be oriented as shown in Figure 1 or rotated 180° depending on how the instrument is used.

Sensor Retainer/Sensor Cover Retainer

The sensor retainer holds the gas sensors in place and snaps onto the right side of the case. It has 4 diffusion ports, one for each sensor, and has recessed areas in it for the charcoal filter, the H₂S removal filters, and the sensor cover. The sensor cover retainer snaps onto the sensor retainer. Two screws secure the sensor retainer and the sensor cover retainer to the case.

Sensors

The Model GX-2001 uses four sensors to monitor HC (combustible gases), O₂, CO, and H₂S simultaneously. The sensors are protected by filters that allow atmosphere to diffuse inward. The sensors use different detection principles, as described below.

Combustible Gas Sensor

The LEL sensor detects combustible gas and vapors in the atmosphere with a catalytic element. The reaction of gas with oxygen on the catalyst causes a change in the resistance of the element which affects the current flowing through it. The current is amplified by the Model GX-2001's circuitry, converted to a measurement of combustible gas concentration, and displayed on the LCD.

CAUTION: *Do not expose the combustible sensor to high concentrations of combustible gas such as that from a butane lighter. Exposure to high concentrations of combustible gas may adversely affect the performance of the sensor.*

Oxygen Sensor

The O₂ sensor is a galvanic type of sensor. A membrane covers the cell and allows gas to diffuse into the cell at a rate proportional to the partial pressure of oxygen. The oxygen reacts in the cell and produces a voltage proportional to the concentration of oxygen. The voltage is measured by the Model GX-2001's circuitry, converted to a measurement of gas concentration, and displayed on the LCD.

CO and H₂S Sensors

The CO and H₂S sensors are electrochemical cells that consist of two precious metal electrodes in an acid electrolyte. A gas permeable membrane covers the sensor face and allows gas to diffuse into the electrolyte. The gas reacts in the sensor and produces a current proportional to the concentration of the target gas. The current is amplified by the Model GX-2001's circuitry, converted to a measurement of gas concentration, and displayed on the LCD.

Scrubber Filters/Sensor Cover

Charcoal Filter Disk

The charcoal filter disk is located in the CO sensor diffusion port of the sensor retainer. It is black, has a woven texture, and is impregnated with an H₂S absorbing material. It fits into a recessed area of that port. The CO sensor will respond if exposed to H₂S and certain hydrocarbon gasses. The charcoal filter scrubs these gasses out of the gas sampled to avoid false CO readings. The H₂S absorbing material added to the charcoal filter extends its H₂S absorbing life. If false or elevated CO readings are noticed, especially in the presence of H₂S, change the charcoal filter disk.

NOTE: One H₂S removal filter disk is used over the charcoal filter as an additional guard against false CO readings as described below.

H₂S Removal Filter Disks

The H₂S removal filter disks are used in two locations. One H₂S removal filter disk is located in a recessed area of the combustible gas sensor diffusion port in the sensor retainer. One is also used over the charcoal filter disk in the CO diffusion port to extend the life of the charcoal filter. The H₂S removal filter disks are white when new. They scrub H₂S out of the gas sampled to increase the life of the combustible sensor and the charcoal filter disk. They darken as they absorb H₂S and must be changed when they turn to a dark brown color. The recommended replacement frequency will depend on how often the unit is exposed to H₂S and the concentration. Check the condition of the H₂S removal filter disks quarterly.

Sensor Cover

The sensor cover is white and protects the scrubber filters and sensors from dust and water. It fits over all the sensor diffusion ports and is secured in place by the sensor cover retainer. If the sensor cover becomes dirty, the accuracy of the GX-2001 will be affected. Replace the sensor cover if it appears dirty.

LCD

The LCD is visible through the GX-2001's front panel. Target gas concentrations, the time, battery condition, and alarm indications are displayed on the LCD. When any of the control buttons are pressed, the LCD backlight comes on for 20 seconds.

Control Buttons

Below the LCD are the glow in the dark control buttons. These buttons are MODE/POWER, DISP, and AIR. They turn on the power to the Model GX-2001, and turn it off. They control what is displayed on the LCD, including battery level, time, date, and year, gas concentrations, peak, TWA, and STEL readings, as well as other messages. They also allow you to perform a Demand Zero, change alarm points, change the date and time, and calibrate the instrument. The functions performed by the control buttons are summarized in the following table:

Table 2: The Control Buttons of the Model GX-2001

Button	Function
MODE/POWER	<ul style="list-style-type: none">• Turns the unit on and off.• Turns the LCD back light on.• Displays peak readings (low minimum and high maximum readings for O₂).• Resets the alarm circuit (gas alarms).• Enters Calibration Mode with the AIR button.• Enters Alarm Adjustment Mode with the AIR button.• Enters Time Adjustment Mode with the DISP button.

Table 2: The Control Buttons of the Model GX-2001

Button	Function
DISP	<ul style="list-style-type: none"> • Turns the LCD back light on. • Displays the next target gas when the unit is in Measuring Mode. • Enters Time Adjustment Mode with the MODE/POWER button. • Decreases settings when the unit is in Alarm Adjustment Mode or Time Adjustment Mode. • Toggles between field calibration and auto calibration when the unit is in Calibration Mode.
AIR	<ul style="list-style-type: none"> • Turns the LCD back light on. • Adjusts LCD readings when the a Demand Zero is performed. • Enters Calibration Mode with the MODE/POWER button. • Enters Alarm Adjustment Mode with the MODE/POWER button. • Increases settings when the unit is in Alarm Adjustment Mode or Time Adjustment Mode. • Toggles between field calibration and auto calibration when the unit is in Calibration Mode.

Printed Circuit Boards

The primary function of the Model GX-2001's three printed circuit boards are to amplify the current sent to them from the four gas sensors, convert the current to a meaningful measurement of gas concentration, display the gas concentration on the LCD, store peak, STEL, and TWA readings, and activate the alarm circuit if an alarm point has been reached. They monitor battery level, battery failure, and sensor failure. They also control the Model GX-2001's time function and the various operating modes of the unit.

NOTE: The printed circuit boards contain no user serviceable parts.

Alarm Lights

The Model GX-2001 has two alarm lights located on top of the unit. The alarm lights are two red LEDs that alert you to gas, low battery, and sensor failure alarms.

Buzzer/Vibrator

A solid-state electronic buzzer/vibrator is mounted inside the front case of the Model GX-2001. The buzzer/vibrator sounds and vibrates for gas alarms, and it sounds for unit malfunctions, low battery voltage, and as an indicator during normal use of the many display options of the Model GX-2001.

Battery Pack

Inside the Model GX-2001 is either a Ni-cad or Ni-MH battery pack that supplies 2.4 V to the unit. The battery will run the unit for approximately 10 hours (Ni-Cad) or 18 hours (Ni-MH) when no alarms have been activated during that time period. The battery is fully rechargeable when the Model GX-2001 is placed into the battery charger. The battery icon on the LCD shows the charge remaining in the battery. When the Model GX-2001 detects a low battery voltage, a low battery warning is activated. The battery can be replaced by removing the belt clip on the back of the Model GX-2001. See the maintenance section of this manual for instructions about recharging and replacing the battery.

Belt Clip

On the back of the Model GX-2001 is a belt clip. The belt clip permits the unit to be worn on a belt or to be clipped to a pocket for hands-free gas monitoring. The belt clip may oriented as shown in Figure 1 or rotated 180°. See the Maintenance section for instructions on how to rotate the clip.

Battery Charger

The Model GX-2001 has three battery charger accessories available. All three are used to recharge the unit's battery pack and serve as a convenient station for auto calibration. The battery charger with the PC communication feature has a datalogging port for the down loading of data from the Model GX-2001 to a computer and allows autocalibration using a computer. See "Parts List" for more information.

Start Up

This section explains how to start up the Model GX-2001 and to get it ready for operation.

Start-up Procedure

1. Press and hold the MODE/POWER button for one second to turn on the Model GX-2001 and to activate its LCD. The alarm lights flash, the buzzer sounds, and the vibrator vibrates.
2. The Model GX-2001 tests all elements of the LCD, then displays the year, month, day, and time before displaying the battery voltage. The buzzer sounds again after the battery voltage is displayed.

CAUTION: *If the battery level is low or if the battery icon is flashing and the unit's buzzer sounds, recharge the Model GX-2001's battery.*

3. The four gas sensors inside the Model GX-2001 begin working, and the concentrations of the target gases are displayed on the LCD in the following order: O₂, H₂S, CO, and HC. The Model GX-2001 is now in Measuring Mode. Oxygen is displayed as a percentage (%), H₂S and CO as parts per million (ppm), and HC (combustible gases) as a percentage of the lower explosive limit (% LEL).

NOTE: You can test the oxygen sensor and alarm circuit by exhaling into the oxygen sensor. When the LCD reading falls below the alarm point for oxygen, the buzzer will sound, the vibrator will activate, the LCD reading for oxygen will flash, and the alarm lights will turn on.

Performing a Demand Zero

Before using the Model GX-2001, it is recommended to set the zero reading (demand zero) for the target gasses to ensure accurate gas readings in the monitoring environment.

1. Find a fresh-air environment. This is an environment free of toxic or combustible gasses and of normal oxygen content (20.9%).
2. With the unit on and in Measuring Mode, press and hold the AIR button for about three seconds to allow the Model GX-2001 to set the zero reading for HC, CO, and H₂S and to set the span for O₂.

While you are pressing the AIR button, the LCD displays "Hold," a prompt for you to keep pressing the AIR button.

3. When the zero readings have been set, the LCD displays "Adj," which prompts you to release the AIR button.

Turning Off the Model GX-2001

1. Press and hold the MODE/POWER button for about five seconds to turn off the unit.
2. The buzzer will sound and the LCD back light will flash.
3. Release the button when the LCD is blank. The unit is off.

Operation

This section describes the normal operation of the Model GX-2001. It explains how the unit can be used to display peak gas readings of the four target gasses and to display STEL and TWA readings for H₂S and CO. It covers important issues regarding combustible gas detection. It also covers alarm indications and use of the aspirator adapter accessory.

Normal Operation

After you have powered up the Model GX-2001 and performed a demand zero for the four target gasses following the instructions of the previous section, "Start Up," the Model GX-2001 is in Measuring Mode.

In Measuring Mode, the battery level, time, and gas concentrations are displayed on the LCD. The Model GX-2001 cycles through the four target gases, starting with O₂, then H₂S, CO, and HC. Oxygen is displayed as a percentage (%), H₂S and CO as parts per million (ppm), and HC (combustible gases) as a percentage of the lower explosive limit (% LEL).

Target gas ———— **O2**  ———— Battery charge

Gas concentration ———— **20.9%**

21:19 ———— Time

Figure 2: LCD in Measuring Mode

Displaying Peak Readings

You can display peak readings of the four target gasses when the Model GX-2001 is in Measuring Mode using the MODE/POWER and DISP buttons. With oxygen, you can display both peak and minimum readings.

1. Make sure the Model GX-2001 is in Measuring Mode. The four target gasses should be displaying in sequential order on the LCD.
2. Press the MODE/POWER button once to put the Model GX-2001 in Peak Reading Mode. A small peak (minimum for O₂) symbol is displayed in the lower left corner of the LCD.
3. Press the DISP button to cycle through the four target gases. The peak readings of these gasses are displayed on the LCD.

NOTE: Oxygen has both a peak and minimum reading.

4. To return to Measuring Mode, normal operation, press and release the MODE/POWER button until the normal screen is displayed.

NOTE: While in Peak Reading Mode, if no control button has been pushed for about 15 seconds, the Model GX-2001 returns to Measuring Mode automatically.

Displaying STEL and TWA Readings

With the Model GX-2001, you can display STEL and TWA readings for H₂S and CO. STEL is an acronym for short-term exposure limit, and it shows the average reading for H₂S and CO during the last 15 minutes. TWA is an acronym for time-weighted average, and it shows the average reading for H₂S and CO during the last eight (8) hours. If eight (8) hours has not elapsed since the last time the STEL/TWA readings were cleared, the TWA is still calculated over eight hours, with the missing time assigned a zero (0) value for the readings.

1. Make sure the Model GX-2001 is in Measuring Mode. The four target gasses should be displaying in sequential order on the LCD.
2. Using the DISP button, display either H₂S or CO on the LCD.
3. With either H₂S or CO displayed on the LCD, press the MODE/POWER button twice to put the Model GX-2001 in STEL Reading Mode. "STEL" displays next to the time reading on the LCD.
4. To put the Model GX-2001 in TWA Reading Mode, press the MODE/POWER button again while the unit is in STEL Reading Mode. "TWA" displays next to the time reading on the LCD.
5. Press the DISP button to toggle between the TWA reading for H₂S and CO.
6. To return to Measuring Mode, normal operation, press the MODE/POWER button.

NOTE: While in STEL or TWA Reading Mode, if no control button has been pushed for about 15 seconds, the Model GX-2001 returns to Measuring Mode automatically.

Combustible Gas Detection

There are two issues that must be considered when checking for combustible gas.

- The combustible sensor will respond to any combustible gas. The standard calibration for the GX-2001 combustible channel is to methane (CH₄). If the instrument is to be used to monitor for a different combustible gas, such as hexane or propane, it should be calibrated to that gas.

The table below lists the conversion factors for several hydrocarbon gasses **if the GX-2001 is calibrated to methane**. To use this table, multiply the display reading on the combustible gas channel by the factor in the appropriate row to obtain the actual gas concentration. For example, if you are detecting pentane and the display reads 10% LEL on the combustible channel, you actually have 10% LEL x 1.35 = 13.5% LEL pentane present.

Table 3: LEL Hydrocarbon Conversions

Gas	LEL Conversion Factor (Methane Calibration)	Gas	LEL Conversion Factor (Methane Calibration)
Acetone	1.92	Iso Butane	1.56
Acetylene	2.00	MEK	1.92
Benzene	2.00	Methane	1.00
Ethane	1.25	Methanol	1.65
Ethanol	1.75	Pentane	1.35
Ethylene	1.20	Propane	1.52
Heptane	1.92	Propylene	1.33
Hexane	1.65	Toluene	2.00
Hydrogen	1.00	Xylene	0.93
IPA	2.50		

- The GX-2001 provides the combustible sensor with some protection against exposure to high levels of combustible gas. It does this by turning off the combustible sensor power temporarily when it determines that an over scale (more than 100% LEL) concentration of combustible gas is present that may damage the sensor. Nevertheless, concentrations of combustible gas of more than 100% LEL can still affect the zero level or calibration of the combustible sensor if the concentration is high enough.

CAUTION: *Do not expose the combustible sensor to high concentrations of combustible gas such as that from a butane lighter. Exposure to high concentrations of combustible gas may adversely affect the perform of the sensor.*

Alarms

This section covers alarm indications, including multiple alarms and trouble alarms. It also tells you how to reset the Model GX-2001 after an alarm has occurred and how to respond to an alarm condition.

NOTE: False alarms may be caused by radio frequency (RF) or electromagnetic (EMI) interference. Keep the GX-2001 away from RF and EMI sources such as radio transmitters or large motors.

Alarm Indications

The Model GX-2001 will sound an alarm and the unit will vibrate when one of the target gas concentrations rises above the first alarm point, or in the case of oxygen, falls below the low point alarm setting for that gas.

The Model GX-2001 also sounds an alarm and vibrates when the second alarm point is reached for HC, CO, and H₂S, when the concentration of oxygen rises above 23.5% in the monitoring area, and when the STEL and TWA alarm points are reached for CO and H₂S.

When a trouble condition occurs, such as a sensor failure or low battery charge, the unit will also sound an alarm but it will not vibrate.

The table below summarizes the types of alarms produced by the Model GX-2001.

Table 4: Alarm Types and Indications

Alarm Type	LCD Indications	Other Indications
<p>Alarm 1 Concentration of gas rises above the first alarm point, or for O₂, falls below the low point setting.</p>	<ul style="list-style-type: none"> Name of gas displayed. Alarm light flashes once per second. Back light turns on. Gas reading flashes. 	<p>Pulsing tone once per second Unit vibrates once per second</p>
<p>Alarm 2 Concentration of gas rises above second alarm point, or for O₂, rises above the high point setting.</p>	<ul style="list-style-type: none"> Name of gas displayed. Alarm light flashes twice per second. Back light turns on. Gas reading flashes. 	<p>Pulsing tone twice per second Unit vibrates twice per second</p>
<p>TWA or STEL Concentration of CO or H₂S rises above the TWA or STEL alarm point setting.</p>	<ul style="list-style-type: none"> Name of gas displayed. Alarm light flashes once per second. Back light turns on. TWA or STEL blinking. 	<p>Pulsing tone once per second Unit vibrates once per second</p>
<p>Over Range</p>	<ul style="list-style-type: none"> Name of gas displayed. Gas reading replaced by blinking brackets. □□□□ Alarm light flashes. Back light turns on. 	<p>Pulsing tone once per second Unit vibrates once per second</p>
<p>Low Battery Warning</p>	<ul style="list-style-type: none"> Battery icon flashes. 	<p>None</p>
<p>Dead Battery Alarm</p>	<ul style="list-style-type: none"> Gas reading replaced by FAIL. Battery icon flashes. 	<p>Double Pulsing Tone (two pulses in quick succession)</p>

Table 4: Alarm Types and Indications

Alarm Type	LCD Indications	Other Indications
Sensor Failure	<ul style="list-style-type: none">• Name of gas sensor displayed.• Gas reading replaced by FAIL.	Double Pulsing Tone (two pulses in quick succession)

Multiple Alarms

If more than one gas alarm is activated, the LCD shows the concentration of the gas that triggered the last alarm. To see the concentration of the other gasses, press the DISP button until the gas of interest is displayed. When the DISP button is pressed, the displayed gas will stay displayed for 20 seconds, then the display will cycle.

For example, if concentrations of both CO and H₂S in the monitoring environment were to rise above their respective alarm points and CO was the first to do so, the concentration of H₂S would display on the LCD since it was the most recent alarm event. Pressing the DISP button would display the concentration of CO for 20 seconds, then HC for three seconds, etc.

If the TWA and STEL alarms are triggered, alarm indications for both gasses occur at the same time. The LCD would then display both "TWA" and "STEL" next to the time and both "TWA" and "STEL" would be blinking.

Resetting Alarms

To reset an alarm, press the MODE/POWER button after the gas reading falls below the Alarm 1 point (or above for oxygen). If a TWA alarm has been activated, it cannot be reset unless you turn off the unit.

NOTE: Even though gas concentrations may have returned to normal or have fallen below the alarm point, the alarm indications will continue until you have reset the alarm using the MODE/POWER button.

Responding to Alarms

This section describes response to gas, over range, battery, and sensor failure alarms.

Responding to Gas Alarms

1. Determine which gas alarm has been activated.
2. Follow your established procedure for an increasing gas condition or a decreasing oxygen condition.
3. Reset the alarm using the MODE/POWER button once the alarm condition has been cleared.

Responding to Over Range Alarms

WARNING: An over range condition may indicate an extreme combustible gas, toxic gas, or oxygen content condition. Confirm a normal condition with a different Model GX-2001 or with another gas detecting device.

1. Determine which gas alarm has been activated.
2. Follow your established procedure for an increasing gas condition.
3. Reset the alarm using the MODE/POWER button once the alarm condition has cleared.
4. Calibrate the Model GX-2001 as described in the calibration section of this manual.
5. If the over range condition continues, you may need to replace the sensor that has triggered the over range alarm.
6. If the over range condition continues after you have replaced the sensor, contact RKI Instruments, Inc. for further instructions.

Responding to Battery Alarms

WARNING: The Model GX-2001 is not operational as a gas monitoring device during a dead battery alarm. Take the Model GX-2001 to a non-hazardous area and recharge the battery as described in "Recharging the Battery Pack."

The Model GX-2001 is fully functional during a low battery warning. However, depending upon conditions, the Model GX-2001 has only two-to-three hours of operating time left after the low level battery alarm has been triggered. Recharge the battery pack as soon as possible as described in "Recharging the Battery Pack."

NOTE: Alarms and the back light feature consume battery power and reduce the amount of operating time remaining.

Responding to Sensor Failure Alarms

1. Determine which sensor has triggered the sensor failure alarm.
2. Try calibrating the sensor first, as described in “Calibration,” before replacing it.
3. If the sensor failure continues, replace the sensor as described in “Replacing a Sensor.”
4. If the sensor failure condition continues after you have replaced the sensor, contact RKI Instruments, Inc. for further instructions.

Aspirator Adapter

The aspirator adapter accessory is used when it is necessary to draw sample from an area that cannot be entered or that must be checked for safety before entry, such as a tank or confined space.

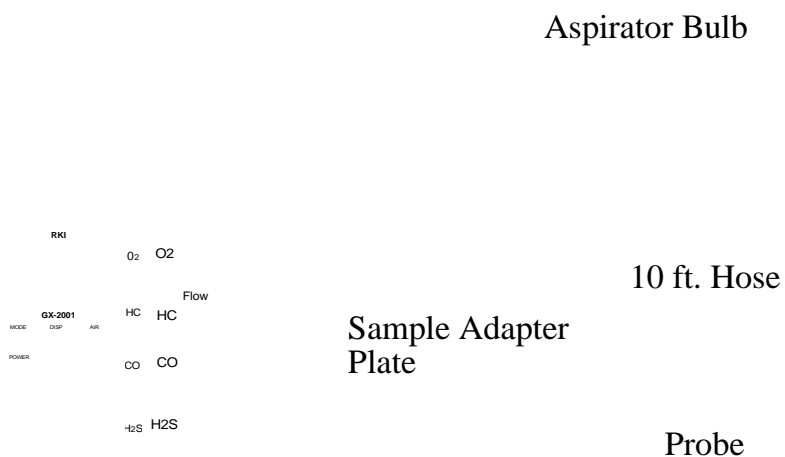

Figure 3: GX-2001 Aspirator Adapter

1. Turn on the GX-2001 as directed in the Startup section.
2. Attach the adapter plate of the aspirator adapter to the sensor side of the instrument.
3. Screw the probe onto the threaded end of the 10 ft. hose.
4. Attached the 10 ft. hose and probe to the aspirator bulb.
5. Insert the end of he probe into the area to be sampled.
6. Squeeze and release the aspirator bulb 15 times.

Monitor the readings and note if any alarms occur. The readings will peak shortly after the last squeeze and may decrease before all the channels can be checked. To see the maximum readings for each channel, display the peak readings for each channel (see the Displaying Peak Readings section).

NOTE: The peak readings for each channel are saved until a higher peak is recorded or the instrument is turned off. If a gas is present but the level does not exceed the previous peak level, the previous peak will be displayed on the Peak Reading Screen.

Displaying and Setting the Alarm Points

The Model GX-2001 allows you to display and set the alarm points of the four target gasses. Each of the target gasses has both a low (Alarm 1) and high (Alarm 2) alarm setting. Two gasses, CO and H₂S, have STEL and TWA alarm points. The alarm point for oxygen is measured as a percentage of oxygen in the atmosphere. The alarm point for HC is measured as a percentage of the lower explosive limit (% LEL), and CO and H₂S alarm points are measured in parts per million (ppm). The alarm points and their factory settings are summarized in the table below:

Table 5: Alarm Points of the Four Target Gasses

Gas	Alarm 1	Alarm 2	STEL	TWA
O ₂	19.5% Decreasing	23.5%	None	None
HC Combustibles	10% LEL	50% LEL	None	None
CO	25 ppm	50 ppm	200 ppm	25 ppm
H ₂ S	10 ppm	30 ppm	15 ppm	10 ppm

In the table above, Alarm 1 and Alarm 2 for HC, CO, and H₂S refer to a rising concentration of these gasses. The first alarm is triggered at the Alarm 1 concentration listed in the table. For HC that would be 10% LEL, for CO that would be 25 ppm, and for H₂S that would be 10 ppm. The second alarm is triggered when the Alarm 2 concentration is reached. For oxygen, Alarm 1 is triggered when the concentration of oxygen falls below 19.5%. When the concentration of oxygen rises above 23.5%, Alarm 2 is activated.

Display and Adjust the Alarm Points

1. Make sure the Model GX-2001 is turned off. The LCD should be blank.
2. Press and hold the AIR button, then press and hold the MODE/POWER button.
3. As soon as segments appear on the display (approximately one second), release the AIR button. When the unit “beeps,” release the MODE/POWER button to put the Model GX-2001 into Alarm Point Adjustment Mode. The LCD should show the Alarm 1 setting for O₂ and the battery level.

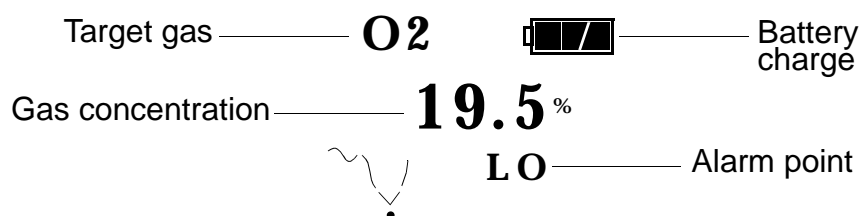

Figure 4: LCD in Alarm Adjustment Mode

NOTE: If the LCD should show “CAL,” the Model GX-2001 is in Calibration Mode. You will need to press and hold the MODE/POWER button to turn off the unit. Begin again with step 2 above.

4. Use the MODE/POWER button to cycle through the alarm points of the target gasses. Oxygen is displayed first followed by H₂S, CO, then HC. Use the AIR button to increase the alarm point and the DISP button to decrease the alarm point. When using the MODE/POWER button, press it once to display the next reading. If you press and hold the MODE/POWER button, you may turn off the unit.

NOTE: You can only cycle through the target gasses once before the Model GX-2001 goes into Start-up Mode followed by Measuring Mode. If you want to cycle through the gasses again, press and hold the MODE/POWER button to turn off the Model GX-2001. Then begin with step 2 above to put the unit back into Alarm Point Adjustment Mode.

5. When you are finished viewing or adjusting the alarm point settings, press the MODE/POWER button repeatedly until the ROM number for your unit appears on the LCD. (the ROM is the component that contains the software that runs the Model GX-2001.) The Model GX-2001 will then go into Start-up Mode followed by Measuring Mode.

Setting the Time and Date

The Model GX-2001 allows you to set the time and date.

1. Make sure the Model GX-2001 is turned off. The LCD should be blank.
2. Press and hold the DISP button, then press and hold the MODE/POWER button to put the Model GX-2001 into Time Adjustment Mode. Release the buttons when the unit beeps. The LCD shows the year, month, day, and time. The year is flashing at the top of the LCD.

2000 _____ Year
Month _____ 11.13 _____ Day
Hour _____ 21:06 _____ Minute

Figure 5: LCD in Time Adjustment Mode

3. To change the time and date,
 - Use the MODE/POWER button to cycle through the time and date values.
 - You can only change a value if it is flashing.
 - Use the AIR button to increase a value.
 - Use the DISP button to decrease a value.

NOTE: Once you have cycled through the time and date values, the Model GX-2001 will go into Start-up Mode followed by Measuring Mode. If you want to cycle through the time and date values again, press and hold the MODE/POWER button to turn off the Model GX-2001. Then begin with step 2 above to put the unit back into Time Adjustment Mode.

4. To leave Time Adjustment Mode, press the MODE/POWER button to cycle through to the end of the time and date values. The Model GX-2001 then enters Start-up Mode followed by Measuring Mode.

Calibration

This section covers the calibration of the Model GX-2001. Setting the zero reading is described first followed by single calibration and auto calibration. For single calibration, you are told what is needed to complete the task, how to assemble the calibration kit, and how to set the span readings of the four target gasses. The same topics are covered for auto calibration.

WARNING: *Use a 0.5 LPM (liters per minute) fixed flow regulator when calibrating. Use of a different flow rate may adversely affect the accuracy of the calibration.*

CAUTION: *BEFORE EACH DAY'S USAGE SENSITIVITY MUST BE TESTED ON A KNOWN CONCENTRATION OF THE COMBUSTIBLE TARGET GAS, TYPICALLY METHANE, EQUIVALENT TO 25 - 50% OF FULL SCALE CONCENTRATION. ACCURACY MUST BE WITHIN -0 - + 20% OF ACTUAL. ACCURACY MAY BE CORRECTED BY FOLLOWING THE CALIBRATION INSTRUCTIONS FOR THE COMBUSTIBLE CHANNEL BELOW.*

If the combustible channel passes the above response test and does not require calibration, the unit should still be calibrated periodically. The optimum frequency of calibration depends heavily on how the GX-2001 is used. For example, instruments used daily may need to be calibrated weekly or monthly, while instruments that are used only a few times a year may need to be calibrated before each use. Typical calibration frequencies range from monthly to quarterly. Make sure to perform the combustible channel response test as described above and make sure to develop a calibration schedule tailored to your application that takes this test and required calibration resulting from this test into account.

Setting the Zero Readings for All Target Gasses

Whether you will calibrate the Model GX-2001 using single calibration or auto calibration, you will need to set the zero readings first before setting the span readings for each gas.

1. Find a fresh-air environment. This is an environment free of toxic or combustible gasses and of normal oxygen content (20.9%).
2. Turn on the Model GX-2001 by pressing and holding the MODE/POWER button for one second.
3. Press and hold the AIR button for about three seconds to allow the Model GX-2001 to set the zero reading for HC, CO, and H₂S and to set the span for O₂.

4. While you are pressing the AIR button, the LCD displays “Hold,” a prompt for you to keep pressing the AIR button.
5. When the zero readings have been set, the LCD displays “Adj,” which prompts you to release the AIR button.

Single Calibration

This section tells you how to calibrate the Model GX-2001 using the single calibration (CAL) menu.

Preparation

Before you calibrate the Model GX-2001, you must set the zero readings as described in “Setting the Zero Readings for All Target Gasses.” You will also need the supplies listed below. Calibration kits from RKI Instruments, Inc. are available for this purpose (see “Parts List”).

- Either a 3-gas or 4-gas calibration cylinder with the following recommended concentrations:
 - 50% LEL methane (CH₄)
 - 12% oxygen
 - 50 ppm CO
 - 25ppm H₂S (4-gas cylinder only)
 - Balance of nitrogen
- To carry out the calibration, you will need a fixed-flow regulator with a flow rate of 0.5 LPM (liters per minute), non-absorbent tubing, and a calibration adapter plate that will fit over the Model GX-2001’s four sensors.

Assembling the Calibration Kit

WARNING: Calibrate the Model GX-2001 in a non-hazardous environment.

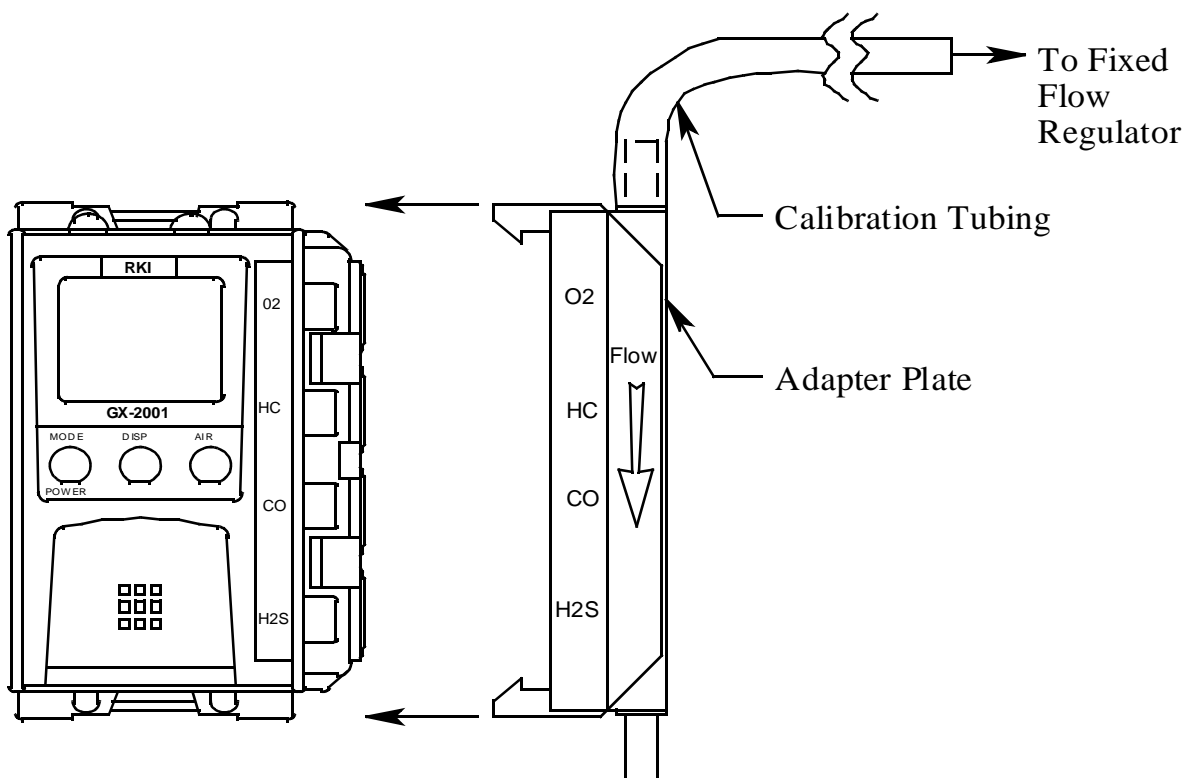

Figure 6: Assembling the Calibration Kit and Attaching It to the Model GX-2001

1. Attach the adapter plate to the unit. It snaps onto the sensor area.
2. Attach the calibration tubing to the adapter plate, then attach the opposite end of the tubing to the regulator.

NOTE: Do not attach the regulator to the gas cylinder at this time.

If you are going to calibrate the Model GX-2001 for all the target gasses at one time, it is recommended that you start with the oxygen sensor first followed by the H₂S, CO, and HC sensors in that order.

The reason for this calibration sequence is that while the Model GX-2001 is in Calibration Mode, you will only be able to toggle through the target gasses one time, using the MODE/POWER button, before the unit goes into its start-up sequence.

If you want to go back to a target gas, you will need to turn off the Model GX-2001 before putting the unit back into Calibration Mode.

Setting the Span Readings for All Target Gasses

When setting the span readings manually for one gas sensor at time, you will calibrate each gas sensor individually.

1. Make sure you have set the zero readings for all the target gasses and have set up the calibration kit as described in the procedure above. If you are going to calibrate all the target gasses, start with O₂ followed by H₂S, CO, and HC.
2. Make sure the Model GX-2001 is off.
3. Press and hold the AIR button, then press and hold the MODE/POWER button. Release both buttons when you hear a “beep.” The LCD displays “CAL,” the battery level, and the time.
4. Pressing the MODE/POWER button allows you to toggle through each target gas once so you can calibrate that gas. In the upper left corner of the LCD, “CAL” and the name of the target gas being calibrated, such as “O₂,” are displayed alternately in rapid succession.
5. Attach the regulator to the gas cylinder. The fixed-flow regulator automatically begins introducing the calibration sample to the sensors.
6. Let the gas flow for two minutes before adjusting the span.
7. Use the AIR button to increase the reading and the DISP button to decrease the reading until you have matched the concentration of the calibration sample.

NOTE: If you cannot adjust the display reading to match the calibration sample, you may need to replace the sensor you are calibrating, as described in “Replacing a Sensor.”

8. After you have set the span for the sensor, press the MODE/POWER button to display the next sensor. In the upper left corner of the LCD, “CAL” and the name of the target gas being calibrated, such as “H₂S” are displayed alternately in rapid succession.
9. Repeat steps 7 and 8 above to set the span for the remaining target gasses.
10. When you are finished setting the span for the target gasses, remove the regulator from the cylinder, remove the adapter plate from the unit, then store the contents of the calibration kit in a safe place for future use. The tubing may be left on the adapter plate for convenience.
11. Use the MODE/POWER button to place the Model GX-2001 in Measuring Mode or to turn the unit off.

Auto Calibration

This section tells you how to calibrate the Model GX-2001 using the auto calibration (AUTO CAL) menu.

Preparation

Before you calibrate the Model GX-2001, you must set the zero readings as described in “Setting the Zero Readings for All Target Gasses.” You will also need the supplies listed below. Calibration kits from RKI Instruments, Inc. are available for this purpose (see “Parts List”).

- Either a 3-gas or 4-gas calibration cylinder with the following recommended concentrations:
 - 50% LEL methane (CH₄)
 - 12% oxygen
 - 50 ppm CO
 - 25 ppm H₂S (4-gas cylinder only)
 - Balance of nitrogen
- To carry out the calibration, you will need a fixed-flow regulator with a flow rate of 0.5 LPM and non-absorbent tubing.

Setting Up the Model GX-2001 for Auto Calibration

WARNING: Calibrate the Model GX-2001 in a non-hazardous environment.

1. Attach the adapter plate to the unit.
2. Attach the calibration tubing to the adapter plate, then attach the opposite end of the tubing to the regulator.

Setting the Span Readings for All the Target Gasses

1. Make sure you have set the zero readings for all the target gasses and have set up the GX-2001 for calibration as described in the procedure above.
2. **Turn off the Model GX-2001 if it is on.**
3. With the GX-2001 off, press and hold the AIR button, then press and hold the MODE/POWER button. Release both buttons when you hear a “beep.” The LCD displays “CAL,” the battery level, and the time.
4. Press either the DISP or AIR button to select Auto Calibration Mode. The word, “Auto” is displayed next to the battery icon at the top of the LCD.

5. Press the MODE/POWER button again. You may now check the current auto calibration settings of the unit's gas sensors, beginning with oxygen. In the upper left corner of the LCD, the word, "CAL," and the name of the gas sensor being checked will flash alternately. The LCD will also show the current auto calibration setting (e.g., 12.0% for O₂).

To skip checking the autocalibration settings, go to step 6.

To check the autocalibration settings, press either the DISP or AIR button to check the current auto calibration setting of the next gas sensor. (By using the DISP or AIR button, you will be able to cycle through all the sensors.)

NOTE: The auto calibration settings should match the gas concentration levels in the four-gas (or three-gas) cylinder. They cannot be changed in the Auto Calibration menu. If an auto calibration setting must be changed to match a cylinder concentration, the datalogging software must be used, so the Datalogging/Charger Station, 49-2156RK, must be used.

6. Press the MODE/POWER button to proceed. The current gas reading is shown. Press the DISP or AIR button to scroll through the gasses.
7. Attach the regulator to the cylinder. The fixed flow regulator automatically starts introducing the calibration sample to the sensors.
8. Let the gas flow for two minutes, then press the MODE/POWER button to perform auto calibration for all sensors.

NOTE: If "FAIL" displays on the LCD and the buzzer sounds while auto calibration is being performed, you may need to replace sensor(s), as described in "Replacing a Sensor." Press the MODE/POWER button to see what sensors have failed.

9. The Model GX-2001 will enter its start-up sequence if no sensors have failed the auto calibration.
10. Remove the regulator from the cylinder, remove the adapter plate from the unit, then store the contents of the calibration kit in a safe place for future use. The tubing may be left on the adapter plate for convenience.

Maintenance

This section describes troubleshooting procedures for the Model GX-2001. It also describes how to recharge the Model GX-2001's battery pack as well as how to replace the unit's battery, sensor cover, and gas sensors.

WARNING: *RKI Instruments, Inc. recommends that service, calibration, and repair of RKI instruments be performed by personnel properly trained for this work. Replacing sensors and other parts with original equipment does not affect the intrinsic safety of the instrument.*

Troubleshooting

The troubleshooting table describes error messages, symptoms, probable causes, and recommended action for problems you may encounter with the Model GX-2001.

Table 6: Troubleshooting the Model GX-2001

Symptoms	Probable Causes	Recommended Action
<ul style="list-style-type: none">The LCD is blank.	<ul style="list-style-type: none">The unit may have been turned off.The battery pack may need recharging.The battery pack may need replacement.	<ol style="list-style-type: none">To turn on the unit, press and hold the MODE/POWER button.If the unit does not turn on, the battery pack may need to be recharged. Place the Model GX-2001 in its battery charger and recharge the battery pack.If recharging the unit does not work, replace the battery pack.If the difficulties continue, contact RKI Instruments, Inc. for further instruction.

Table 6: Troubleshooting the Model GX-2001

Symptoms	Probable Causes	Recommended Action
<ul style="list-style-type: none"> The LCD shows abnormally high or low readings but other gas detection instruments do not. 	<ul style="list-style-type: none"> The Model GX-2001 may need to be recalibrated. The sensor for the affected channel(s) may need replacement. 	<ol style="list-style-type: none"> Recalibrate the unit. Replace the sensor for the affected channel(s). If the difficulties continue, contact RKI Instruments for further instruction.
<ul style="list-style-type: none"> “FAIL” displays during auto calibration or unable to set the response readings during single calibration. 	<ul style="list-style-type: none"> The auto calibration values may not match the cylinder gas concentrations. (auto calibration only) The H₂S removal filter disk or the charcoal filter disk over the CO sensor are saturated. The sample gas is not reaching the sensor because of a bad connection The calibration cylinder may be out of gas or is outdated. The sensor for the affected channel(s) may need replacement. 	<ol style="list-style-type: none"> Check all calibration tubing for leaks or for any bad connections. Make sure the Model GX-2001 has been properly set up for calibration. Change the charcoal filter disk and the H₂S removal filter over the CO sensor diffusion port. Verify that the calibration cylinder contains an adequate supply of fresh test sample. If the fail condition continues, replace the sensor(s). If the difficulties continue, contact RKI Instruments, Inc. for further instruction.

Recharging the GX-2001's Battery Pack

WARNING: *To prevent ignition of a hazardous atmosphere, batteries must only be changed or charged in an area known to be nonhazardous.*

CAUTION: *To be used with RKI Ni-cad battery pack p/n 49-1602RK or Ni-MH battery pack 49-1605RK. Charge only with RKI charger p/n 49-2155RK, 49-2156RK, or 49-2163RK.*

1. Verify that the Model GX-2001 is off.
2. Plug the battery charger's AC power cord into an electrical outlet.

NOTE: Two of the three GX-2001 chargers, the 49-2155RK and 49-2156RK, may be powered from 100-240 VAC 50/60 Hz. The 49-2163RK may only be powered from 100-120 VAC 50/60 Hz. The 49-2156RK has a PC communication feature for data downloading. See "Parts List" for more information.

3. Place the Model GX-2001 in the battery charger.
4. While the unit is being charged, the red LED on the top face of the charger is on.
5. When the red LED turns off, the GX-2001's battery pack is fully charged. It takes approximately 90 minutes to recharge a fully discharged battery pack.
6. To verify whether the battery pack is fully recharged, remove the unit from the battery charger, then press the MODE/POWER button to start up the unit. If the battery icon on the LCD is fully colored in, then the unit has been completely recharged.



NOTE: A battery pack will have a typical service life of 500 charging cycles minimum.

When using the GX-2001, be sure to drain the battery as much as possible before recharging. If the battery is regularly only partially drained before charging, the battery will experience a "memory effect" and the run time of the instrument will be decreased.

Replacing the Battery Pack

WARNING: Replace the battery pack in a non-hazardous environment.

Replace the battery pack when it no longer holds a charge.

1. Verify that the Model GX-2001 is off.
2. On the left or right side of the Model GX-2001, unscrew two of the screws securing the belt clip retaining pins to the unit.
3. Carefully slide out the small pins holding the belt clip to the unit by grasping them with your fingers.
4. Unscrew the four screws holding the metal plate to the back of the Model GX-2001, then remove the plate.
5. Carefully press on the upper tab of the battery with a small flat blade screw driver and gently pry up to remove the battery from the GX-2001's housing.

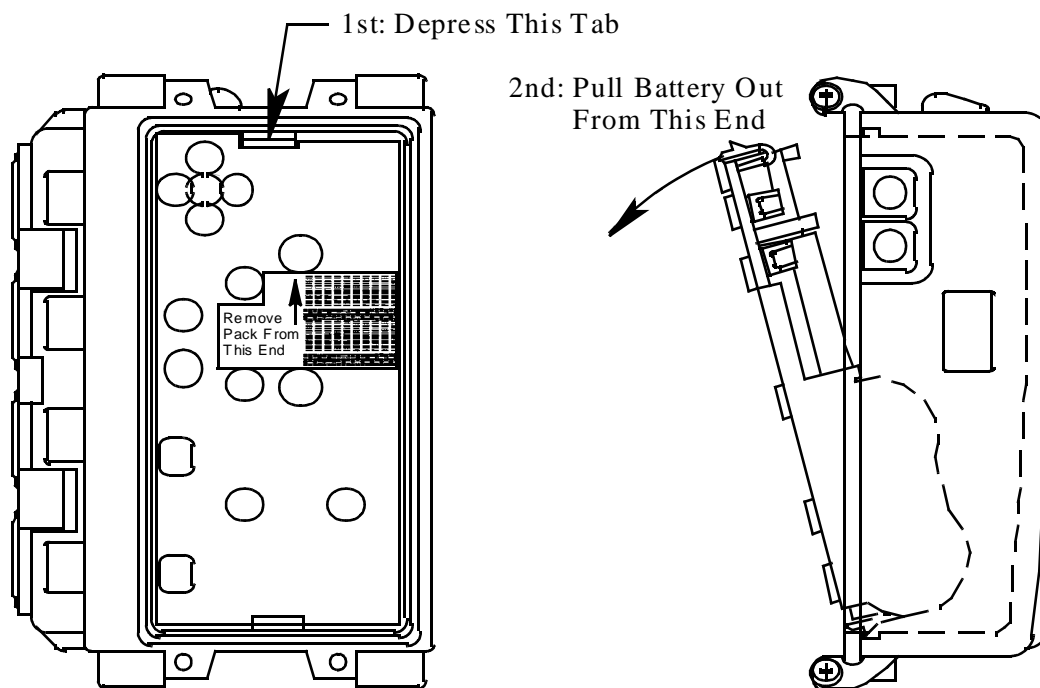

Shown Without Clip & Rear Cover Plate

Figure 7: Removing the Battery from the Model GX-2001

6. Replace the battery. Insert the bottom first so it snaps into place, then the top.

CAUTION: When replacing the battery, be certain to insert the bottom of the battery (the thickest and largest part) **first** into the housing of the Model GX-2001 before inserting the top. Inserting the top of the battery first before the bottom may damage the circuit board underneath.

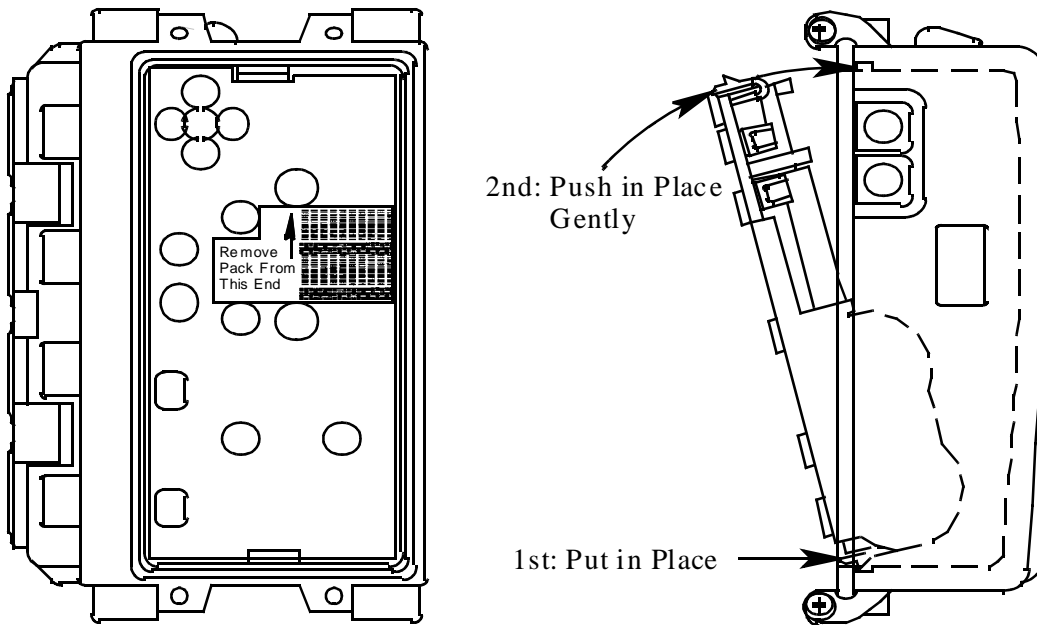

Shown Without Clip & Rear Cover Plate

Figure 8: Inserting a New Battery into the Model GX-2001

7. Replace the screws, small pins, metal plate, and belt clip in reverse order as described in steps 2 through 4 above.

Replacing the Scrubber Filters

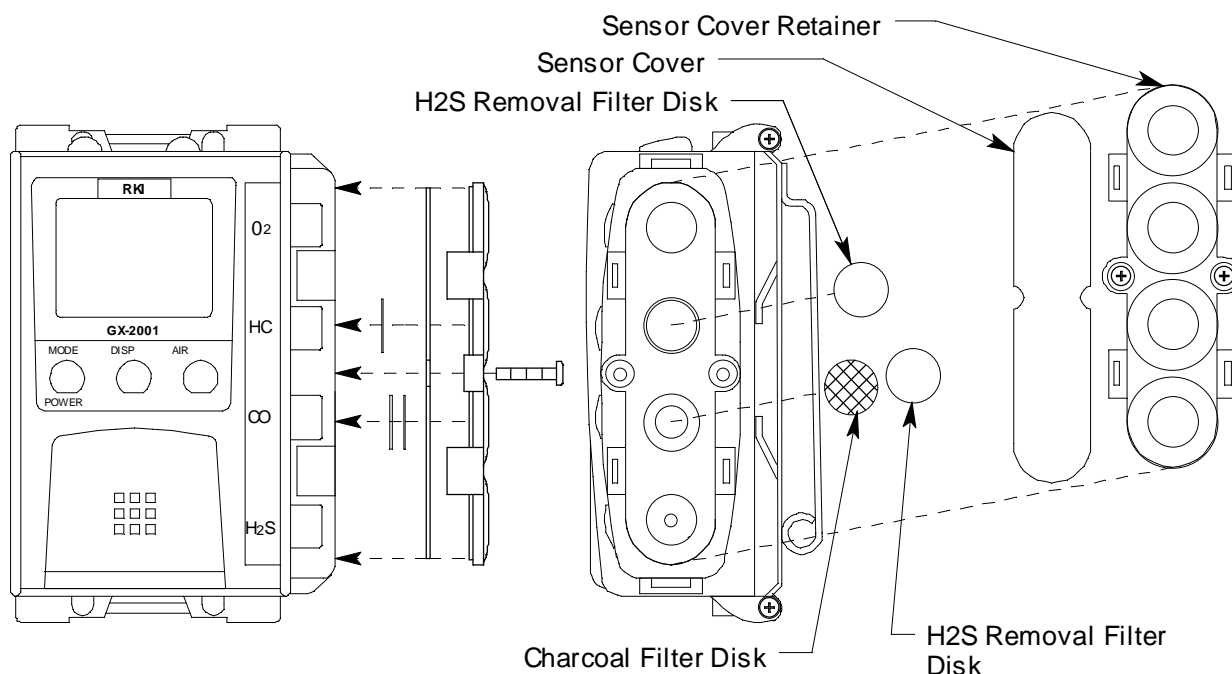

Figure 9: Removing the Sensor Retainer and Replacing the Scrubber Filters

1. Verify that the Model GX-2001 is off.
2. Unscrew the two screws that secure the sensor retainer and sensor cover retainer to the Model GX-2001 and remove them.
3. Using a small flat blade screwdriver, gently pry each side of the sensor cover retainer away from the sensor retainer.
4. Remove the sensor cover to gain access to the scrubbers.
5. The charcoal filter disk is located in the CO sensor diffusion port. One filter disk is used. One H₂S filter disk is also used in the CO sensor diffusion port. It is installed over the charcoal filter disk.
One H₂S removal filter disk is also located in the combustible gas diffusion port.
6. When the appropriate scrubber filters have been replaced, reinstall the sensor cover.
7. Reattach the sensor cover retainer in its original position. It should snap into place onto the sensor retainer.
8. Replace the two screws that secure the sensor retainer and sensor cover retainer to the Model GX-2001, which you removed in step 2 above.

Replacing the Sensor Cover

WARNING: Replace the sensor cover in a non-hazardous environment.

1. Verify that the Model GX-2001 is off.
2. Unscrew the two screws that secure the sensor retainer and sensor cover retainer to the Model GX-2001 and remove them.
3. Using a small flat blade screwdriver, gently pry each side of the sensor cover retainer away from the sensor retainer.
4. Remove the sensor cover, then insert the replacement cover.
5. Reattach the sensor cover retainer in its original position. It should snap into place onto the sensor retainer.
6. Replace the two screws that secure the sensor retainer and sensor cover retainer to the Model GX-2001, which you removed in step 2 above.

Replacing a Sensor

WARNING: Replace the sensors in a non-hazardous environment.

1. Verify that the Model GX-2001 is off.
2. Unscrew the two screws that secure the sensor retainer (with the sensor cover retainer still attached) to the Model GX-2001 enough to remove the sensor retainer with the screws still in place.

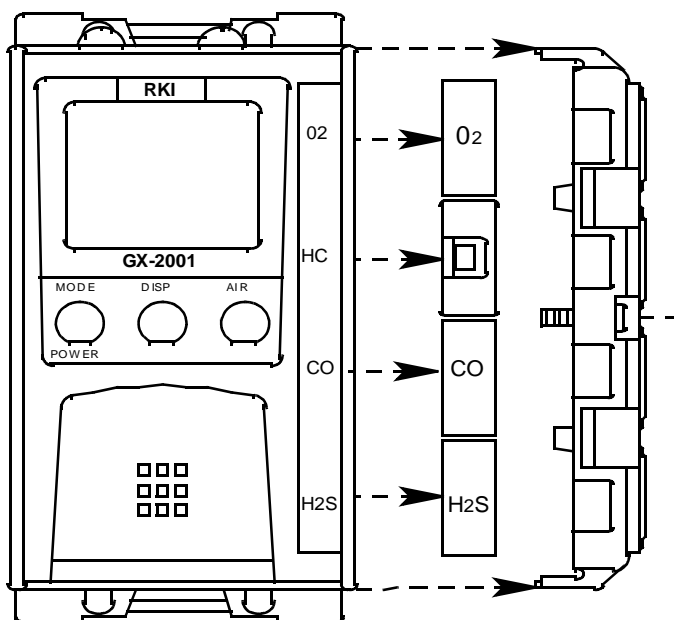

Figure 10: Removing the Sensor Retainer to Replace a Sensor

3. Remove the sensor from its socket.
4. Carefully insert the replacement sensor in the socket.

CAUTION: When replacing a sensor, verify that the sensor is properly aligned with its socket before inserting it into the socket. The CO and H₂S sensors have alignment slots which match up with alignment tabs in the sockets. The combustible gas sensor has two non-polarized contacts which must line up with the contacts in the socket. Forcing a sensor into its socket may damage the sensor or the socket.

Shown w/out Sensor Retainer

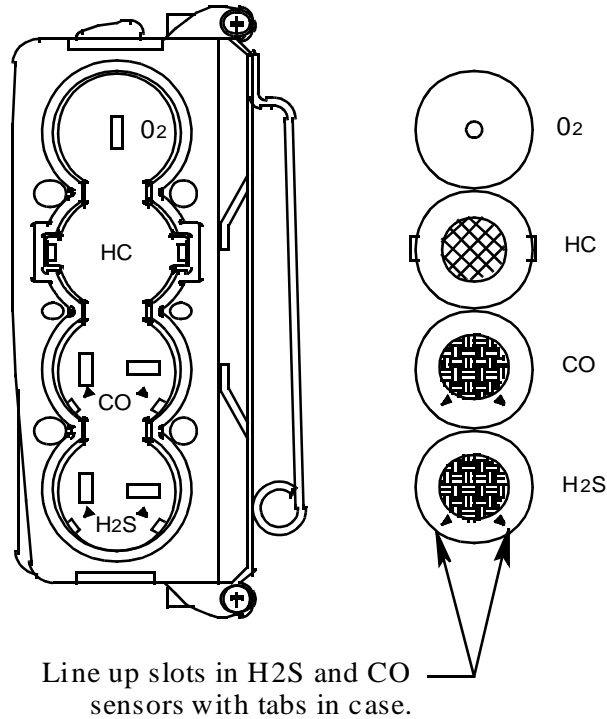

Figure 11: Replacing the Sensors and Their Locations in the Model GX-2001

5. Place the sensor retainer in its original position, then secure it to the Model GX-2001 with the two screws.
6. Start up the Model GX-2001 by pressing and holding the MODE/POWER button.
7. Calibrate the new sensor as described in the calibration section of this manual.

Rotating the Belt Clip

1. On the same side of the unit, remove two of the 4 screws that retain the belt clip retaining pins.
2. Grasp the pins and slide them out.
3. Rotate the belt clip and replace the pins.
4. Replace the two screws that were removed in step 1.

Parts List

Table 7 lists replacement parts and accessories for the Model GX-2001.

Table 7: Parts List

Part Number	Description
06-1248RK	Calibration kit tubing (specify length in feet)
13-0112RK	Wrist strap
13-0113RK	Neck strap
10-1100RK	Screw, self tapping, for case
10-1100RK-02	Replacement screw kit, 8 case screws/4 sensor retainer screws
10-1104RK	Screw, for sensor retainer
21-1823RK	Sensor cover retainer
21-1824RK	Sensor retainer
33-0158RK	Sensor cover, water proof
33-7106RK	Charcoal filter disk, 10 pack, for CO diffusion port
33-7114RK	Filter disk, H ₂ S scrubber, 5 pack, for combustible diffusion port
49-1602RK	Ni-cad battery pack
49-1605RK	Ni-MH battery pack
49-2155RK	Battery charger, 100-240 VAC 50/60 Hz input
49-2156RK	Datalogging/charger station with cable and software for datalogging, 100-240 VAC 50/60 Hz input
49-2163RK	Battery charger, 100-120 VAC 50/60 Hz input
81-GX01HSCO	One 58 ltr. aluminum cylinder, regulator, calibration plate, case & tubing
81-GX01HSCO-LV	One 34 ltr. aluminum cylinder, regulator, calibration plate, case & tubing
81-GX01CO	One 103 ltr. cylinder, regulator, calibration plate, case & tubing

Table 7: Parts List

Part Number	Description
81-GX01CO-LV	One 34 ltr. steel cylinder, regulator, calibration plate, case & tubing
81-0090RK-01	Three-gas calibration cylinder, 50% LEL CH ₄ /12% O ₂ /50 ppm CO, 34 liter steel
81-0090RK-03	Three-gas calibration cylinder, 50% LEL CH ₄ /12% O ₂ /50 ppm CO, 103 liter steel
81-0154RK-02	Four-gas calibration cylinder, 50% LEL CH ₄ /12% O ₂ /50 ppm CO/25 ppm H ₂ S, 58 liter aluminum
81-0154RK-04	Four-gas calibration cylinder, 50% LEL CH ₄ /12% O ₂ /50 ppm CO/25 ppm H ₂ S, 34 liter aluminum
81-1003RK	Regulator, fixed flow, 0.5 LPM, 17/34 liter steel
81-1004RK	Regulator, fixed flow, 0.5 LPM, 58/34 liter aluminum, 103 liter steel
81-1107RK	Calibration/sample cap, rubber
81-1160RK	Hand aspirated sampler, w/10' hose, probe
ES-1821	Carbon monoxide sensor
ES-1821L	Carbon monoxide sensor, for low humidity use
ES-1827	Hydrogen sulfide sensor
ES-1821L	Hydrogen sulfide sensor, for low humidity use
NC-6264AT	Combustibles sensor
OS-BM2	Oxygen sensor