



Optical interferometric method based on image sensor

GAS ANALYZER

MODEL FI-800

Explosion proof for Hydrogen
Exd II B + H₂T4
Approval No.C16730

SOLVENT GAS MONITORING

In drying oven
MEK, Toluene, Xylene, IPA,
Ethyl acetate

FUEL GAS CALORIE CONTROL

City gas, LPG

PURITY CONTROL

In inert gas, in air
H₂ in air



Display



■ Features

- Minimal maintenance cost.
- Applied LED as light source makes low deterioration.
- Optical interferometric sensor makes no sensitivity deterioration.
- No sensor poisoning by corrosive gases and silicone vapors.
- Provides temperature and pressure compensation.



95QR 007

Classified place of business
Tokyo Branch, Chiba-branch



97ER 005

Classified place of business
Tokyo Branch



RIKEN KEIKI

Only one in the world !! Explosion-proof with H₂T4

GAS

- Explosion-proof indicator for Hydrogen gas accepts any installation places.
- Applied optical interferometer as measuring principle keeps distinguished long stability.
- No sensitivity deterioration against corrosive gases, silicon vapors, etc.
- Long life light source with LED.
- High accurate measurement with Fourier analysis technology.
- No reference gas required for the measurement of fuel gas calorie.
- Continuous measurement, minimal maintenance cost.

Measuring method

Case1 : Measurement of pressurized gas

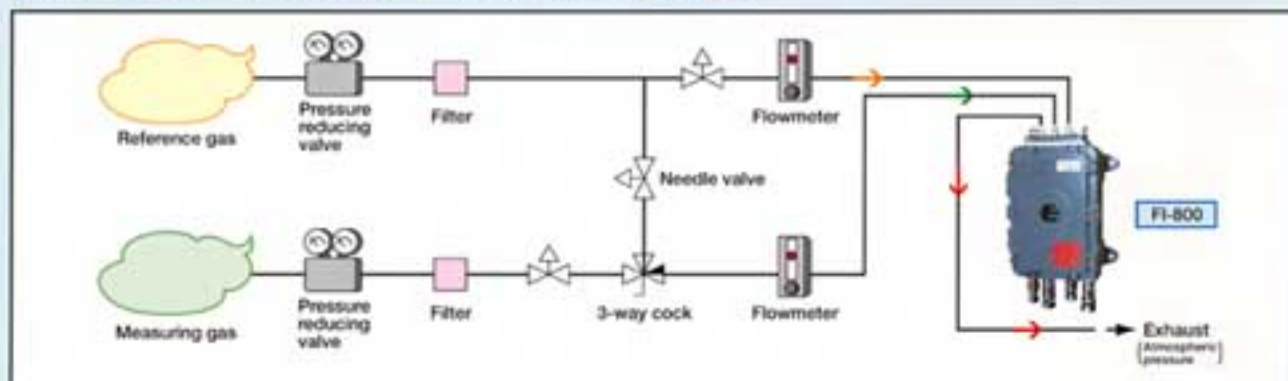

Case2 : Measurement of gas in atmospheric pressure (Sample drawing with pump)

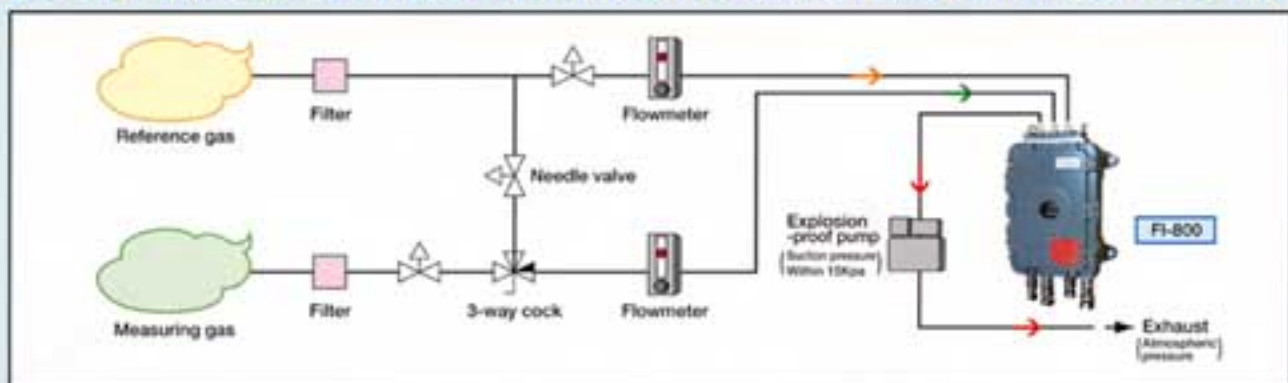

Case3 : Measurement of gas in atmospheric pressure (Sample drawing with air aspirator)

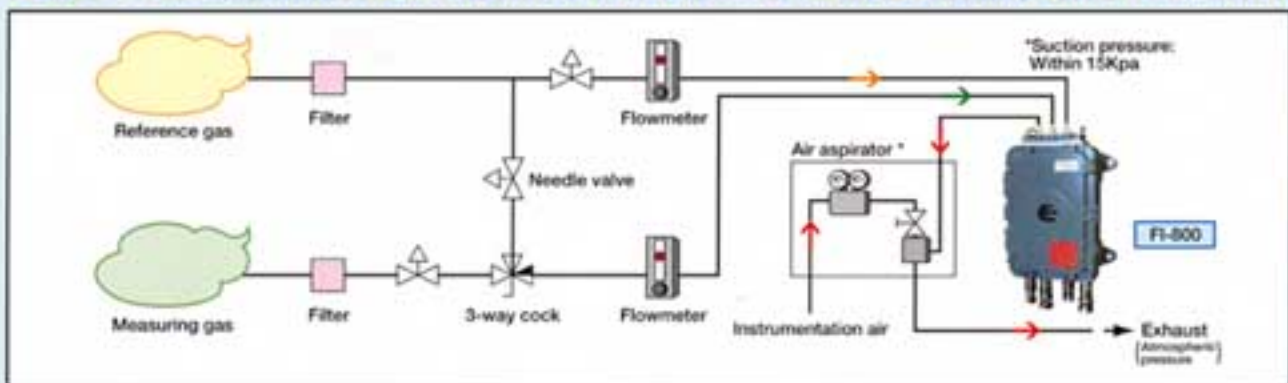

Applications

To Control solvent gas concentration in drying facilities

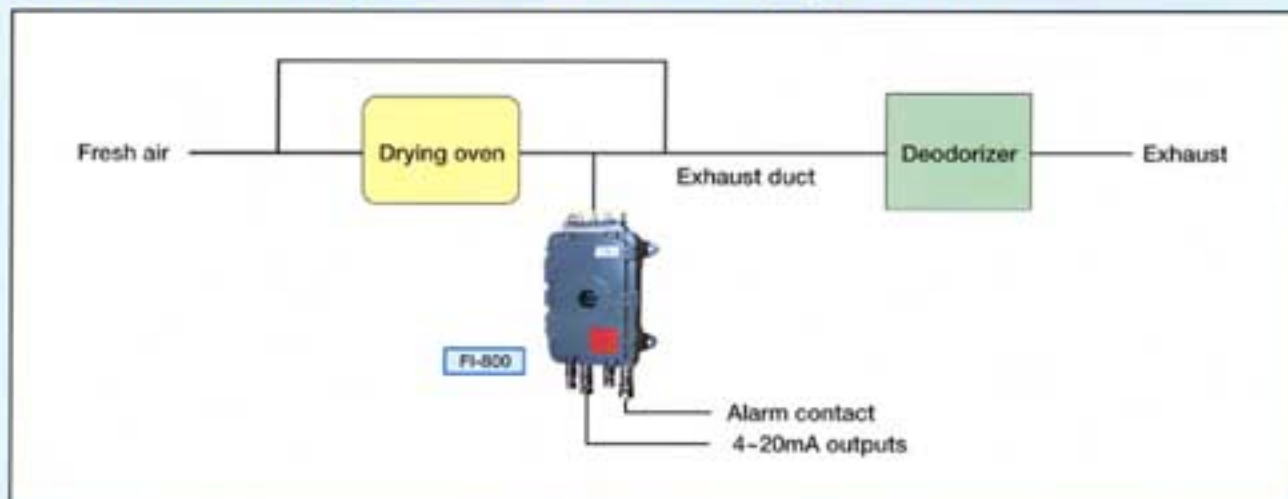

To Control the calorie of city gas, etc.

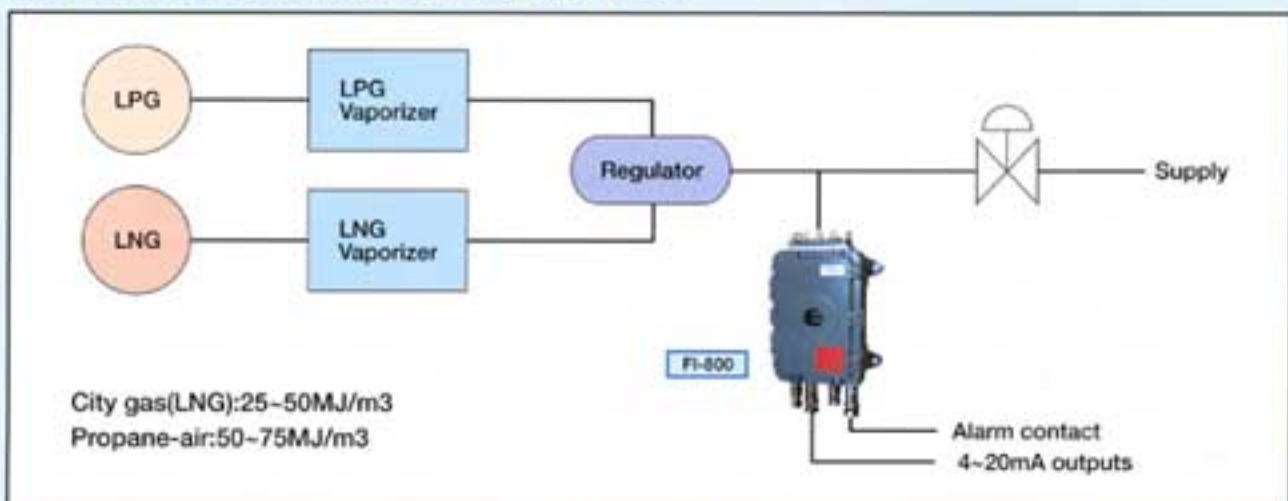

To Control the purity of several gases

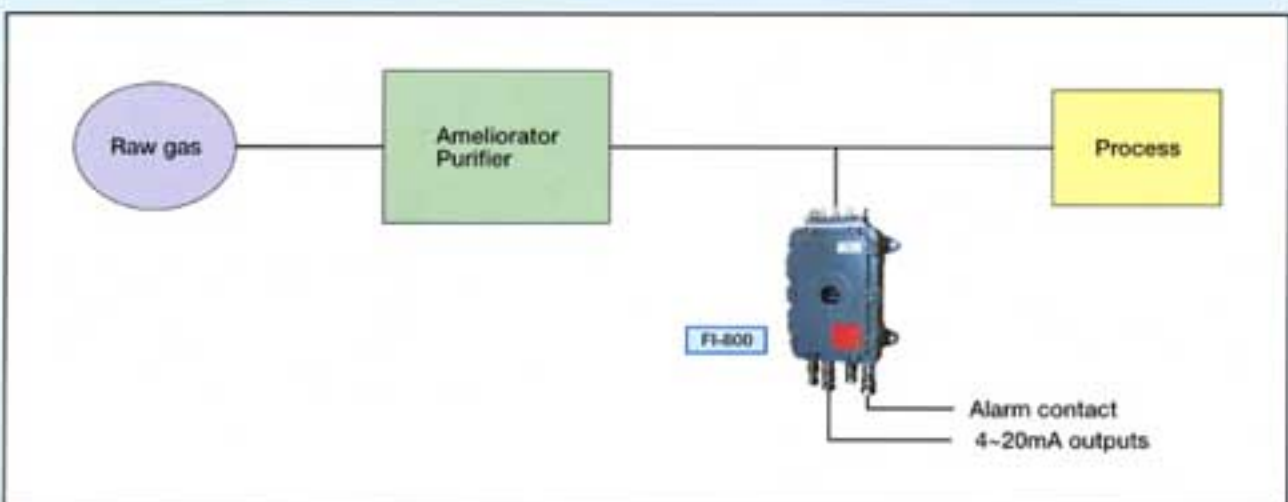

SPECIFICATIONS

Model	FI-800
Detection principle	Optical interferometric method
Measuring gas	Combustible gases & vapors (Please specify when ordering)
Outputs	4-20mA DC (Current output type), resistive load Max 300 Ω
Display	Digital LCD display
Relay contacts	1 st alarm contact, 2 nd alarm contact
Alarm indication	AL1, AL2, LED light
Self-diagnostic function	Low sample flow, decrease of light amount for interferometer light source, decrease of interferometer contrast
Operating temp. & humidity	-10°C - +40°C, below 80%RH (Condensing gas inside FI-800 is not available)
Power requirement	100VAC ~ 220VAC ± 10%, 50/60Hz, max.80VA
Structure	Flame-proof Exd II B + H ₂ T4, Approval No.C16730 in Japan
Outer dimensions	Approx. 220 (W) × 332 (H) × 122 (D)mm
Weight	Approx. 16kg

•Specifications subject to change without notice.

MEASURING RANGE

Measuring gas	Measuring range
Hydrogen	0 - 100vol.%
Toluene	0 - 100%LEL
MEK	0 - 100%LEL
Xylene	0 - 100%LEL
IPA	0 - 100%LEL
Ethyl acetate	0 - 100%LEL
Ethyl alcohol	0 - 100%LEL
Normal hexane	0 - 100%LEL
Methyl alcohol	0 - 100%LEL
Buthyl acetate	0 - 100%LEL
MIBK	0 - 100%LEL
Propane-air	50 - 75MJ/m ³
City gas (LNG)	25 - 50MJ/m ³

DESIGNATIONS

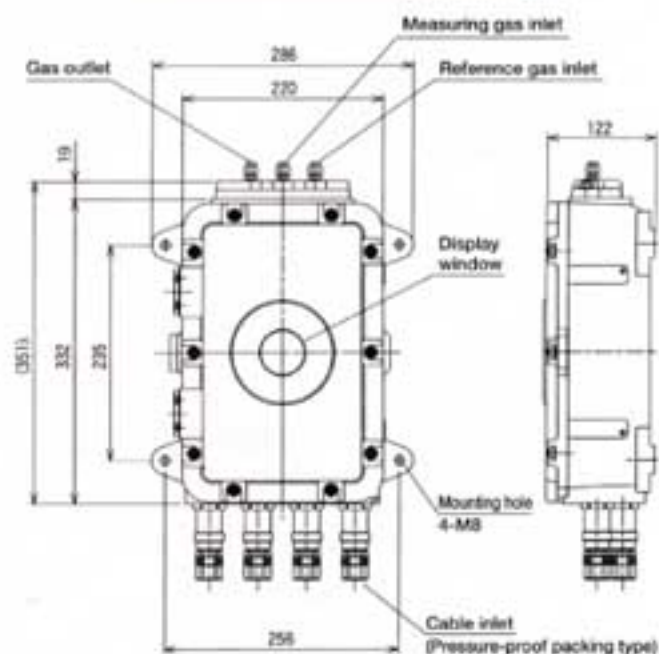

Unit : mm



A9812



ISO 9001:2000

33248 Central Avenue Union City, CA 94587

Toll Free: (800) 754-5165 • Phone: (510) 441-5656 • Fax: (510) 441-5650
 mail4rki@rkiinstruments.com • www.rkiinstruments.com

★ Distributed by: