



**INSTRUMENTS**

**82-5223**  
**115 VAC Pneumatic ESTOP**  
**Operator's Manual**

*Part Number: 71-0572*

*Revision: P1*

*Released: 8/13/21*

---

## Product Warranty

RKI Instruments, Inc. warrants gas alarm equipment sold by us to be free from defects in materials, workmanship, and performance for a period of one year from the date of shipment from RKI Instruments, Inc. Any parts found defective within that period will be repaired or replaced, at our option, free of charge. Parts must be returned to RKI Instruments, Inc. for repair or replacement. This warranty does not apply to those items which by their nature are subject to deterioration or consumption in normal service, and which must be cleaned, repaired or replaced on a routine basis. Examples of such items are:

- |                               |                    |
|-------------------------------|--------------------|
| a) Pump diaphragms and valves | c) Batteries       |
| b) Fuses                      | d) Filter elements |

Warranty is voided by abuse including mechanical damage, alteration, rough handling, or repair procedures not in accordance with instruction manual. This warranty indicates the full extent of our liability, and we are not responsible for removal or replacement costs, local repair costs, transportation costs, or contingent expenses incurred without our prior approval.

*THIS WARRANTY IS EXPRESSLY IN LIEU OF ANY AND ALL OTHER WARRANTIES AND REPRESENTATIONS, EXPRESSED OR IMPLIED, AND ALL OTHER OBLIGATIONS OR LIABILITIES ON THE PART OF RKI INSTRUMENTS, INC. INCLUDING BUT NOT LIMITED TO, THE WARRANTY OF MERCHANTABILITY OR FITNESS FOR A PARTICULAR PURPOSE. IN NO EVENT SHALL RKI INSTRUMENTS, INC. BE LIABLE FOR INDIRECT, INCIDENTAL OR CONSEQUENTIAL LOSS OR DAMAGE OF ANY KIND CONNECTED WITH THE USE OF ITS PRODUCTS OR FAILURE OF ITS PRODUCTS TO FUNCTION OR OPERATE PROPERLY.*

This warranty covers instruments and parts sold to users only by authorized distributors, dealers and representatives as appointed by RKI Instruments, Inc.

We do not assume indemnification for any accident or damage caused by the operation of this gas monitor and our warranty is limited to the replacement of parts or our complete goods. Warranty covers parts and labor performed at RKI Instruments, Inc. only, and does not cover field labor or shipment of parts back to RKI.

---

## Table of Contents

<b>Overview</b> .....	<b>4</b>
<b>About the 82-5223</b> .....	<b>4</b>
<b>Specifications</b> .....	<b>4</b>
<b>Description</b> .....	<b>5</b>
External Description .....	5
Internal Description .....	6
<b>Installation</b> .....	<b>7</b>
Mounting .....	7
Factory Wiring .....	9
Field Wiring .....	10
Making Tubing Connections .....	12
<b>Start Up</b> .....	<b>13</b>
<b>Operation</b> .....	<b>13</b>
Normal Operation .....	13
Alarms .....	13
<b>Replacing the Fuse</b> .....	<b>14</b>
<b>Parts List</b> .....	<b>15</b>

---

## Overview

This manual describes the 82-5223 emergency shutoff. It also describes how to install and start up the device. A spare parts list at the end of this manual lists replacement parts.

---

## About the 82-5223

The 82-5223 is a fixed-mounted device with a solenoid valve, relay, power supply, stack light, and emergency stop button. It requires 115 VAC and compressed air to operate. The solenoid valve inside the 82-5223 is field-plumbed via the “In” and “Out” ports to a user-supplied pneumatic device. When the emergency stop button on the front of the housing door is pushed, the internal solenoid valve de-energizes and the pneumatic line between the 82-5223 and the user-supplied pneumatic device depressurizes through the vent port. A set of remote relay contacts may optionally be used to de-energize the solenoid.

---

## Specifications

Table 1 lists specifications for the sample drawing gas detector.

**Table 1: Specifications**

<b>Construction (housing)</b>	<ul style="list-style-type: none"><li>• PBT/PC blend</li><li>• NEMA 4X</li></ul>
<b>Dimensions</b>	18.82 in. (478 mm) H x 8.09 in. (205 mm) W x 7.19 in. (183 mm) D
<b>Weight</b>	6.6 lbs.
<b>Input Power for Device</b>	115 VAC
<b>“In” and “Out” Ports Pressure Rating</b>	160 psi

---

**WARNING:** *When using the 82-5223, you must follow the instructions and warnings in this manual to assure proper and safe operation of the 82-5223 and to minimize the risk of personal injury.*

---

## Description

### External Description

This section describes the external components of the 82-5223.

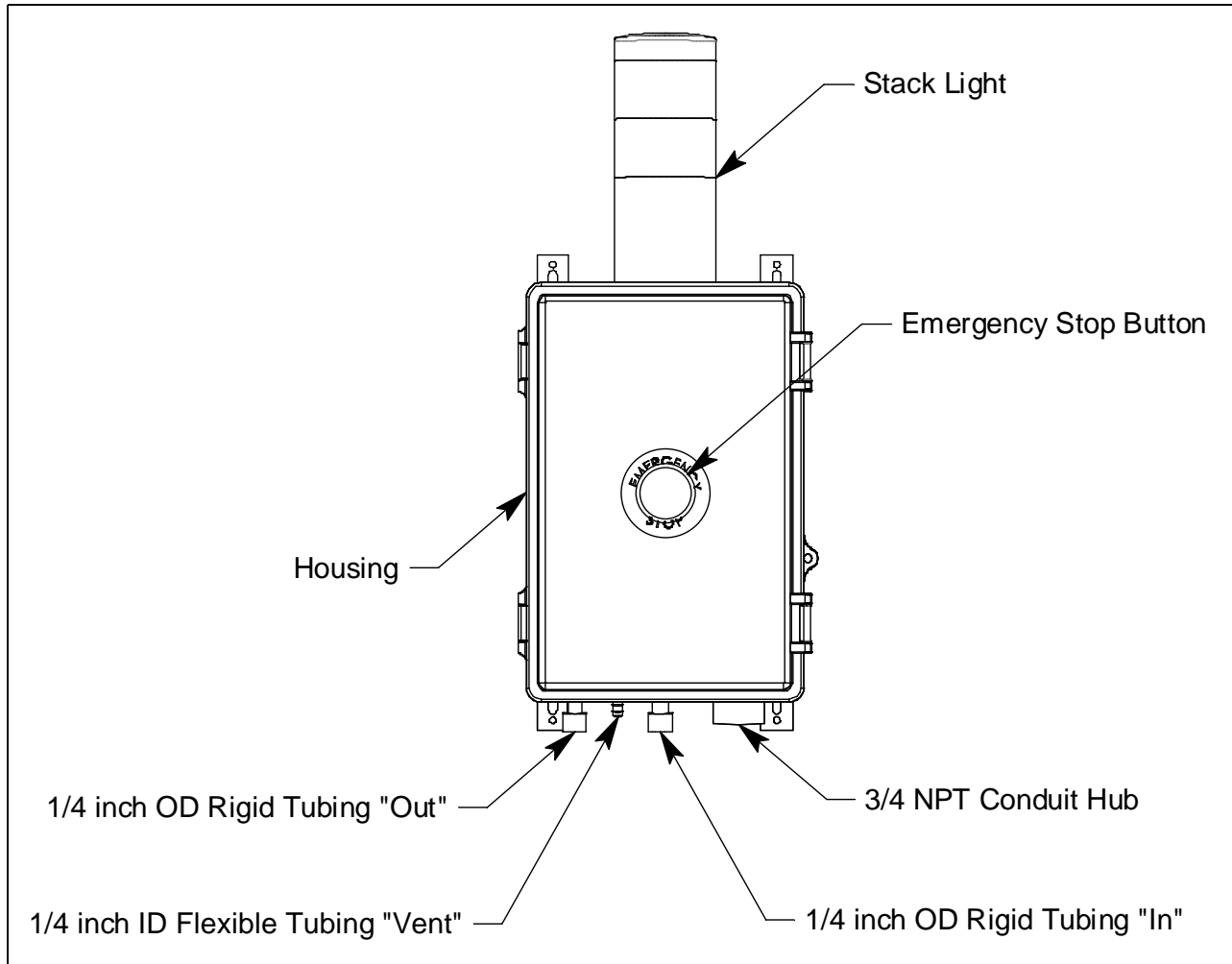

**Figure 1: External Component Location**

### Housing

The 82-5223's PBT/PC blend housing is weather- and corrosion-resistant. It is suitable for installation where general purpose equipment is in use. The housing door is hinged on the left side and is secured by two latches on the right side. A panel inside the housing allows for component installation and mounting. Four mounting feet are attached to the back of the housing (one at each corner). The mounting feet are used to install the housing to a wall.

One conduit hub on the bottom of the housing is for external wiring connections. Two compression fittings for 1/4 inch OD rigid tubing allow for compressed air to be routed to and from the 82-5223. One hose barb fitting for 1/4 inch ID flexible tubing allows for vented air to be routed away from the 82-5223, if desired.

### **Emergency Stop Button**

When the emergency stop button on the front of the 82-5223 is pushed, the internal solenoid valve de-energizes which closes the “In” port and causes the pneumatic line between the 82-5223 and the user-supplied pneumatic device to depressurize through the vent port.

Reset a pushed button by turning it clockwise.

### **Stack Light**

The stack light installed on the top of the housing indicates the status of the solenoid valve’s power line. When the light is green, the pneumatic line between the 82-5223 and the connected pneumatic device is pressurized. When the light is red, the “In” port is closed and the pneumatic line between the 82-5223 and the connected pneumatic device depressurizes through the vent port.

### **Internal Description**

This section describes the internal components of the 82-5223.

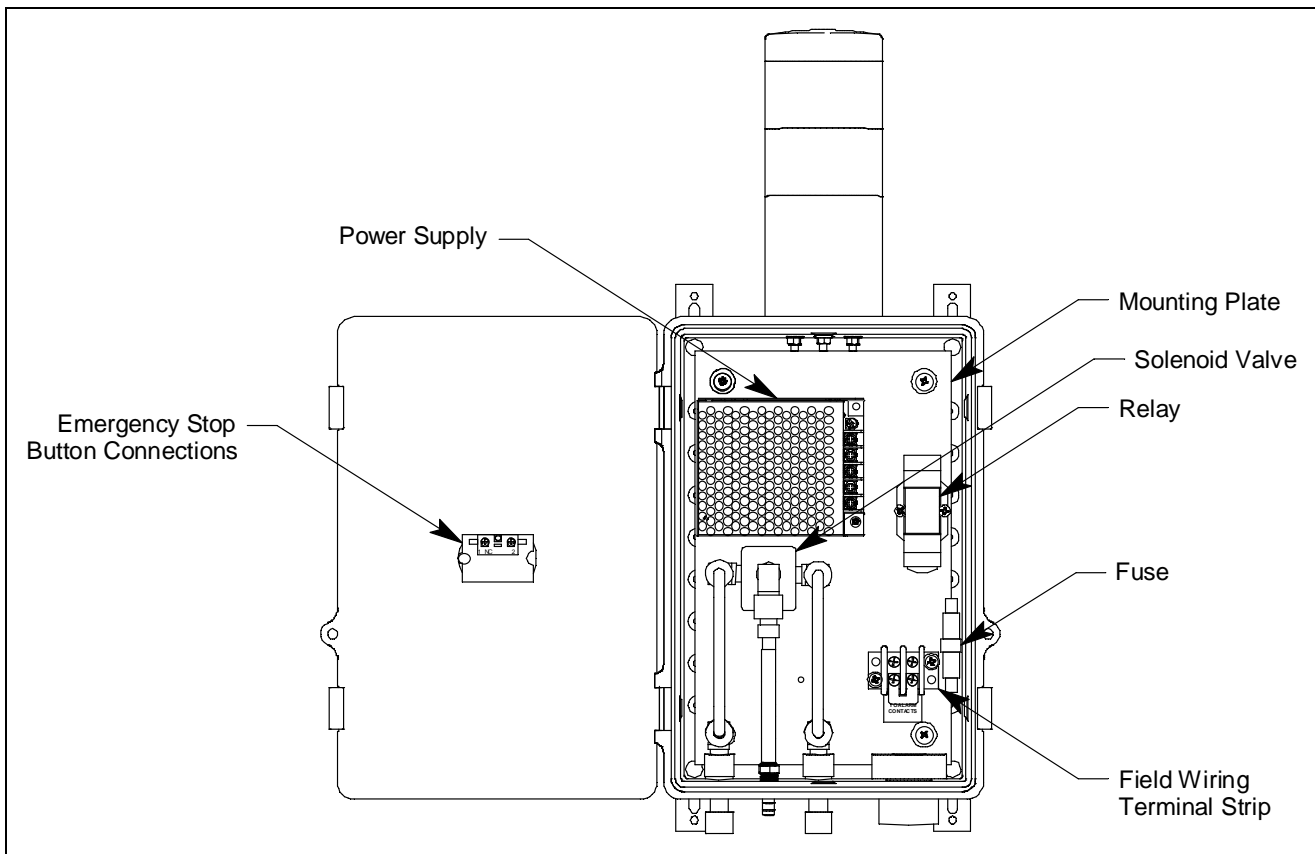

**Figure 2: Internal Component Location**

### **Relay**

A DPDT relay installed on the right side of the 82-5223 controls the stack light’s LED color and also controls the power to the solenoid valve.

### ***Solenoid Valve***

A 3-way solenoid valve installed on the left side of the 82-5223 controls the flow of connected compressed air. When the solenoid is energized, the pneumatic line between the 82-5223 and the connected pneumatic device is pressurized. When the solenoid de-energizes, it closes the “In” port and depressurizes the pneumatic line between the 82-5223 and the connected pneumatic device through the vent port.

### ***Power Supply***

An AC/DC power supply installed on the left side of the 82-5223 converts user-supplied 115 VAC to the 24 VDC that the 82-5223 requires for operation.

### ***Emergency Stop Button Connections***

The emergency stop button’s wiring connections are visible on the back of the door. They are factory wired to the Field Wiring Terminal Strip and the power supply.

### ***Fuse***

A 250V, 1A slow blow fuse is installed in the power line that runs to the stack light. The fuse holder is secured to the right side of the housing with a zip tie.

### ***Field Wiring Terminal Strip***

The Field Wiring Terminal Strip allows for a set of remote relay contacts to be wired into the system as an additional control over the solenoid valve. A factory-installed jumper should be left installed if remote relay contacts are not being wired to the terminal strip.

---

## **Installation**

This section describes how to mount and wire the 82-5223.

### **Mounting**

1. Select the mounting site. When you select the mounting site, consider the following factors:
  - Is an AC power source available?
  - Is a vertical surface available to mount the 82-5223?
  - Is there enough room to open the housing door, make tubing connections, and make wiring connections at the bottom of the housing?
  - Is the stack light visible?
  - Is the location easily accessible in case of an emergency?
2. The 82-5223 is shipped with the mounting feet positioned under the housing. Loosen the screws that secure the feet to the housing, rotate the feet to their mounting position as shown in Figure 3, then tighten the screws.
3. Position the 82-5223 on the vertical mounting surface.

4. Insert 3/16 in. screws through the mounting slots to secure the housing to the mounting surface.

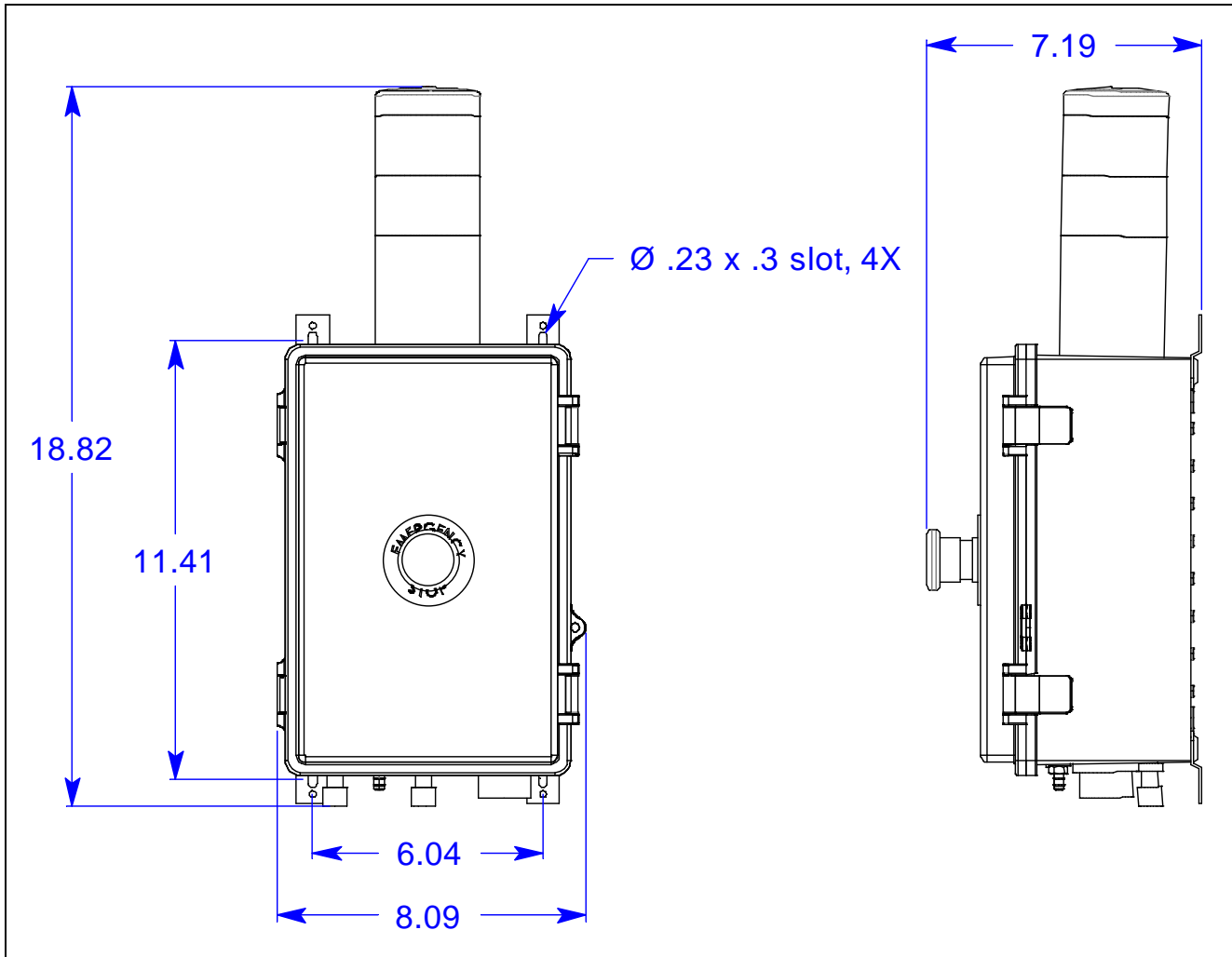

Figure 3: Outline & Mounting Dimensions



## Factory Wiring

The figure below shows factory wiring connections. These wiring connections should not need adjustment.

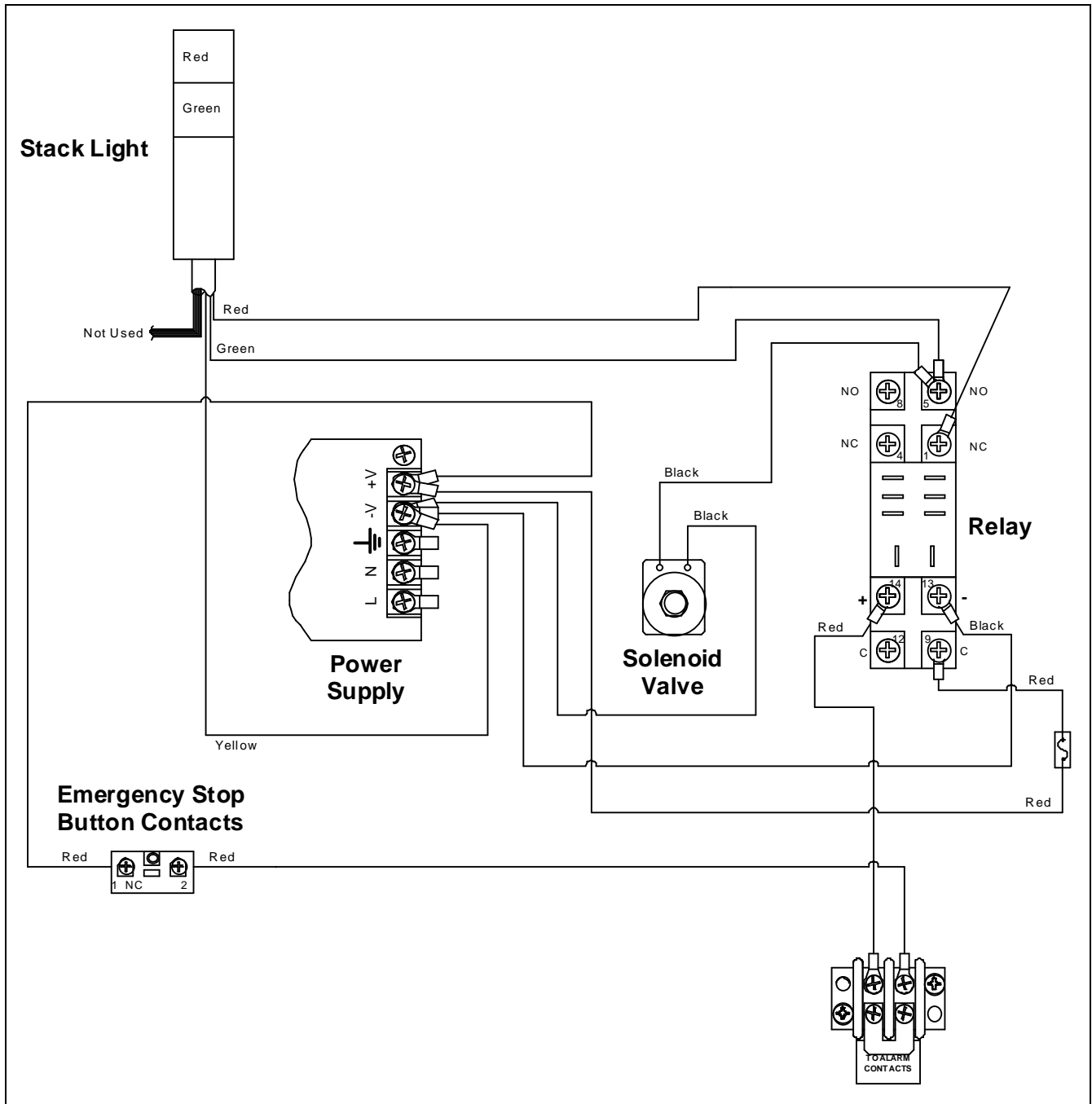

Figure 4: Factory Wiring

## Field Wiring

This section describes how to wire 115 VAC to the power supply and how to wire a remote relay contact into the 82-5223 (optional).

1. Turn off or unplug power to the 82-5223.
2. Open the housing door.

## Power Wiring

3. Guide a 3-conductor cable or 3 wires in conduit through the conduit hub on the bottom of the housing. Use appropriate conduit fittings and construction technique for the environmental rating of the housing. The housing is rated NEMA 4X.
4. Connect one end of the three wires to the L, N, and ground terminals on the power supply.
5. Connect the other end of the three wires to the line, neutral, and ground terminals on a 115 VAC power source (as shown in Figure 5 below).

## Remote Relay Contact Wiring

Connecting the 82-5223 to a remote relay contact is not necessary for operation. Connecting the 82-5223 to a remote relay contact provides another way to de-energize the solenoid valve and depressurize the pneumatic line between the 82-5223 and the connected pneumatic device. If you do connect the 82-5223 to a remote relay contact, the relay contact set used must be normally open and the relay must be configured as normally energized.

6. Remove the jumper from the Field Wiring Terminal Strip.

---

**NOTE:** If you are not connecting a remote relay contact to the 82-5223, the jumper must stay installed.

---

7. Guide a 2-conductor cable or 2 wires in conduit through the conduit hub on the bottom of the 82-5223 housing. Use appropriate conduit fittings and construction technique for the environmental rating of the housing. The housing is rated NEMA 4X.
8. Connect the wires to the Field Wiring Terminal Strip.
9. Guide the other end of the wires to the normally open remote relay contact. Use appropriate conduit fittings and construction technique for the environmental rating of the relay contact's housing. RKI's controllers are rated NEMA 4X.
10. Connect the wires to the NO and C contacts on the remote relay that you want to use to control the solenoid valve (as shown in Figure 5 below). When the relay contact is closed, the solenoid valve is energized and the pneumatic line between the 82-5223 and the connected pneumatic device is pressurized. When the relay contact opens, the solenoid valve de-energizes, the "In" port closes, and the pneumatic line between the 82-5223 and the pneumatic device depressurizes through the vent port.

---

**NOTE:** The relay that you connect to the 82-5223 must be configured as normally energized.

---

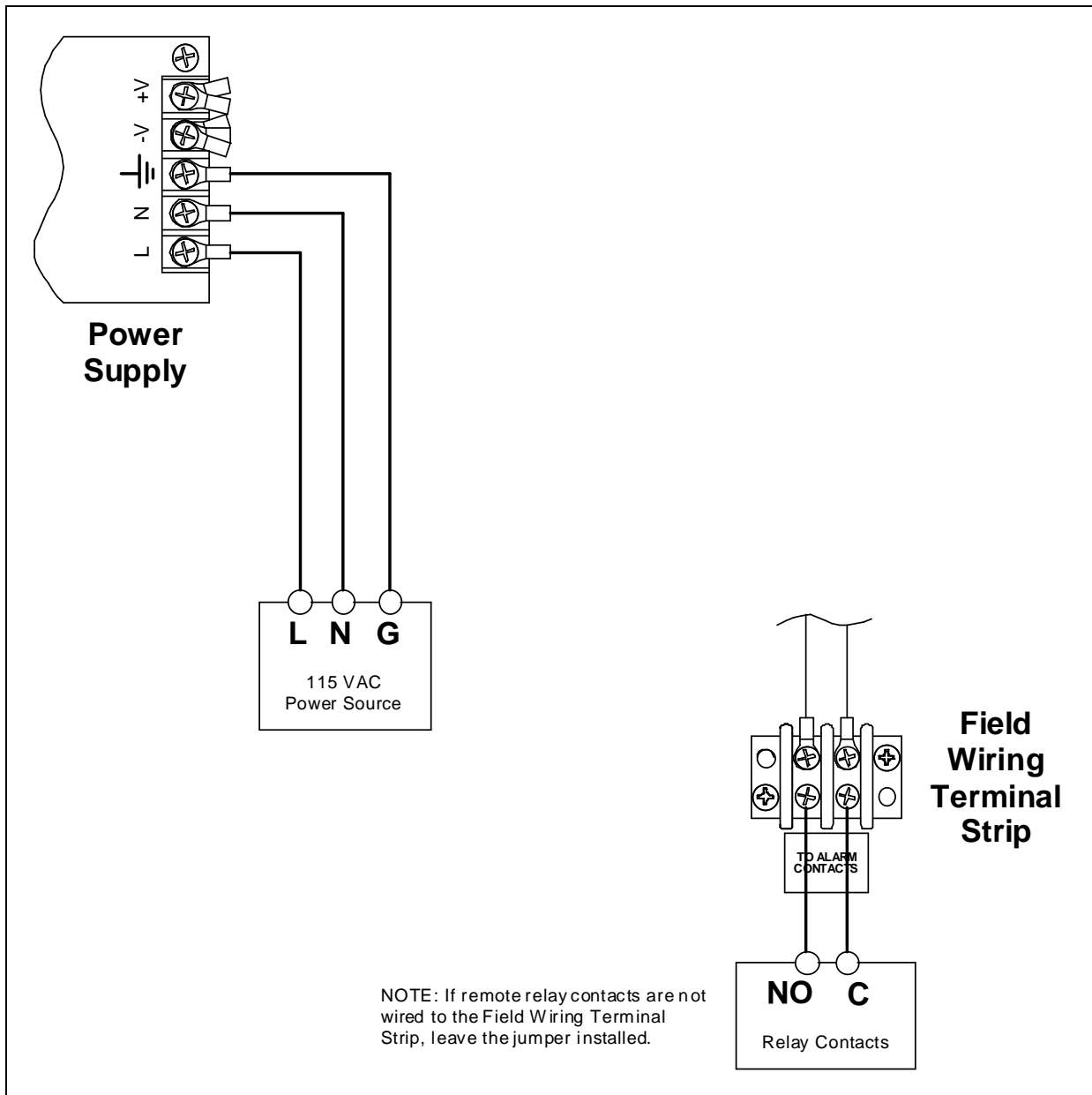

**Figure 5: Field Wiring**

11. Close the housing door.

## Making Tubing Connections

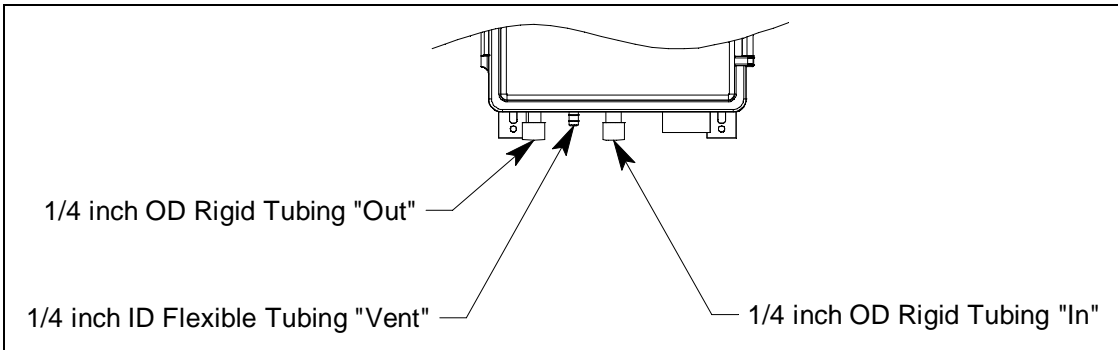

1. Connect a compressed air source up to a maximum of 160 psi to the compression fitting labelled "In" using 1/4 inch OD stainless steel, copper, or aluminum tubing.
2. Connect the compression fitting labelled "Out" to the user-supplied pneumatic device using 1/4 inch OD stainless steel, copper, or aluminum tubing.
3. For each of the 82-5223's compression fittings, hold the fitting still using a 5/8 inch open-end wrench or an adjustable wrench and firmly tighten the nut with a 9/16 inch open-end wrench or an adjustable wrench so the ferrules crimp onto the tubing and make a seal.

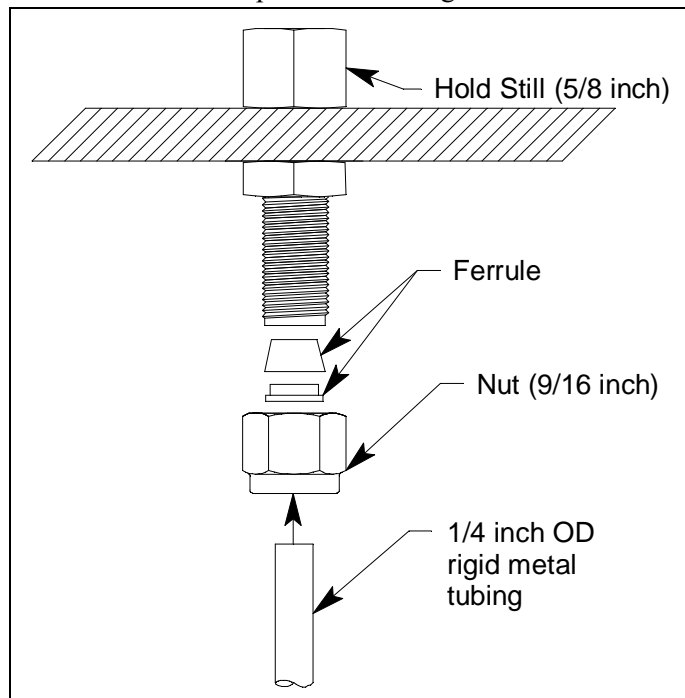

4. If desired, connect a piece of 1/4 inch ID flexible tubing to the hose barb labelled "Vent" and route it away from the 82-5223.

---

## Start Up

1. Be sure the emergency stop button is not pushed. If it is pushed, turn it clockwise to reset it.
2. Turn on the compressed air source, power to the 82-5223, and power to the device whose relay contact is wired to the 82-5223 (if used).
3. Power is immediately applied to the solenoid valve, the pneumatic line between the 82-5223 and the connected pneumatic device pressurizes, and the green LED on the stack light turns on.

---

## Operation

### Normal Operation

During normal operation, the stack light is green, the solenoid valve is energized, and the pneumatic line between the 82-5223 and the connected pneumatic device is pressurized.

### Alarms

If the emergency stop button is pushed or if the remote relay contact opens (if used), the stack light turns red, the solenoid valve de-energizes, the “In” port closes, and the pneumatic line between the 82-5223 and the connected pneumatic device depressurizes through the vent port.

Twist the emergency stop button clockwise to reset it and restore power to the solenoid valve. Reset a remote relay contact alarm as described in the device’s manual.

## Replacing the Fuse

1. Turn off or disconnect power to the 82-5223.
2. Open the 82-5223 housing door.
3. Locate the fuse. It is in the power line shown below and is secured to the right side of the housing with a zip tie.

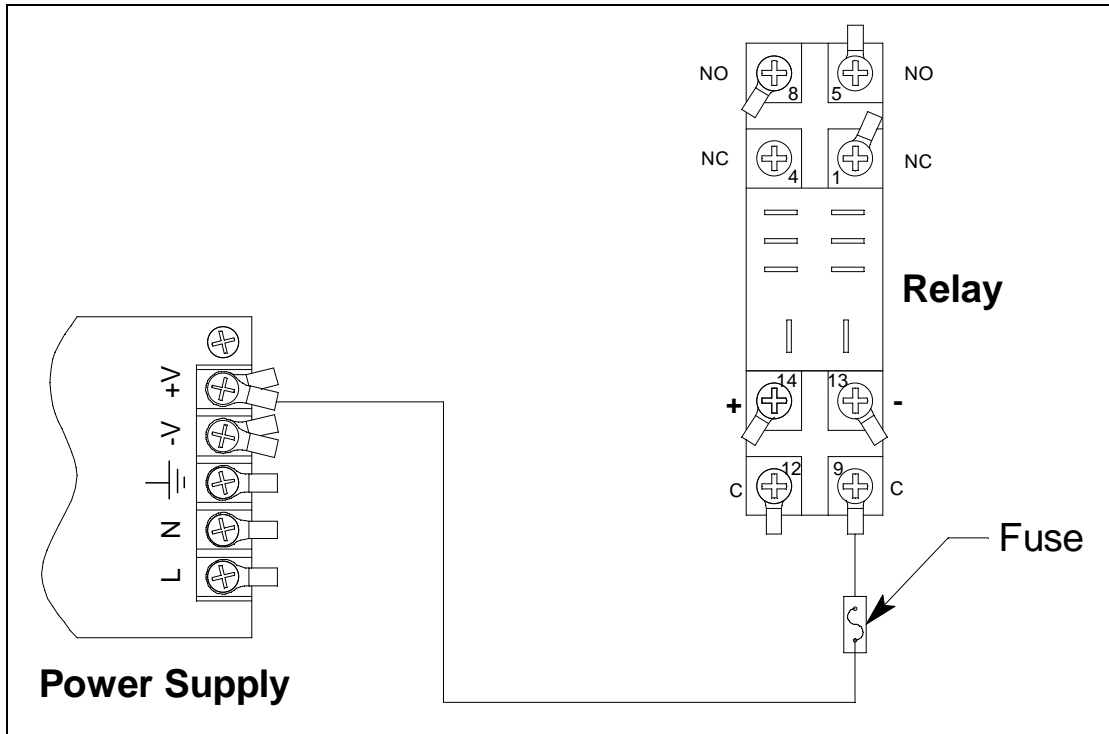

**Figure 6: Fuse Location**

4. Cut the zip tie to access the fuse holder.
5. Unscrew the two halves of the fuse holder.
6. Remove the old fuse.
7. Install the new fuse.
8. Screw the two halves of the fuse holder back together.
9. Use a new zip tie to connect the fuse holder to the right side of the housing.
10. Close the housing door.
11. Plug in or connect power to the 82-5223.

---

## Parts List

Table 2 lists replacement parts and accessories for the 82-5223.

**Table 2: Parts List**

<b>Part Number</b>	<b>Description</b>
43-4143RK	Fuse, 5 mm x 20 mm, 250V, 1A, slow blow
51-0210	Stack light, red/green, steady
71-0572	82-5223 Operator's Manual (this document)