

# **61-1001RKSS Hydrogen Detector Operator's Manual**

*Part Number: 71-0229RK*

*Revision: P1*

*Released: 1/11/18*

## **WARNING**

Read and understand this instruction manual before operating detector. Improper use of the detector could result in bodily harm or death.

Periodic calibration and maintenance of the detector is essential for proper operation and correct readings. Please calibrate and maintain this detector regularly! Frequency of calibration depends upon the type of use you have and the sensor types. Typical calibration frequencies for most applications are between 3 and 6 months, but can be required more often or less often based on your usage.

---

## Product Warranty

RKI Instruments, Inc. warrants gas alarm equipment sold by us to be free from defects in materials, workmanship, and performance for a period of one year from date of shipment from RKI Instruments, Inc. Any parts found defective within that period will be repaired or replaced, at our option, free of charge. This warranty does not apply to those items which by their nature are subject to deterioration or consumption in normal service, and which must be cleaned, repaired, or replaced on a routine basis. Examples of such items are:

- a) Absorbent cartridges
- b) Pump diaphragms and valves
- c) Fuses
- d) Batteries
- e) Filter elements

Warranty is voided by abuse including mechanical damage, alteration, rough handling, or repair procedures not in accordance with the operator's manual. This warranty indicates the full extent of our liability, and we are not responsible for removal or replacement costs, local repair costs, transportation costs, or contingent expenses incurred without our prior approval.

*THIS WARRANTY IS EXPRESSLY IN LIEU OF ANY AND ALL OTHER WARRANTIES AND REPRESENTATIONS, EXPRESSED OR IMPLIED, AND ALL OTHER OBLIGATIONS OR LIABILITIES ON THE PART OF RKI INSTRUMENTS, INC. INCLUDING BUT NOT LIMITED TO, THE WARRANTY OF MERCHANTABILITY OR FITNESS FOR A PARTICULAR PURPOSE. IN NO EVENT SHALL RKI INSTRUMENTS, INC. BE LIABLE FOR INDIRECT, INCIDENTAL, OR CONSEQUENTIAL LOSS OR DAMAGE OF ANY KIND CONNECTED WITH THE USE OF ITS PRODUCTS OR FAILURE OF ITS PRODUCTS TO FUNCTION OR OPERATE PROPERLY.*

This warranty covers instruments and parts sold to users by authorized distributors, dealers, and representatives as appointed by RKI Instruments, Inc.

We do not assume indemnification for any accident or damage caused by the operation of this gas monitor, and our warranty is limited to the replacement of parts or our complete goods.

---

## Table of Contents

<b>Overview</b> .....	<b>1</b>
<b>Specifications</b> .....	<b>1</b>
<b>Description</b> .....	<b>2</b>
NC-6205-01 Hydrogen Detector .....	2
Junction Box .....	2
<b>Installation</b> .....	<b>3</b>
Mounting the Hydrogen Detector .....	3
Wiring the Hydrogen Detector .....	4
<b>Startup</b> .....	<b>6</b>
Introducing Incoming Power .....	6
Setting the Zero Reading .....	6
<b>Maintenance</b> .....	<b>7</b>
Preventive Maintenance .....	7
Troubleshooting .....	8
Replacing the Hydrogen Detector .....	9
<b>Calibration</b> .....	<b>10</b>
Preparing for Calibration .....	10
Setting the Zero Reading .....	10
Setting the Response Reading .....	10
Returning to Normal Operation .....	11
<b>Parts List</b> .....	<b>11</b>

---

## Overview

This manual describes the 61-1001RKSS hydrogen detector (internal amplifier type). This manual also describes how to install, start up, maintain, and calibrate the detector when it is used with a gas monitoring controller. A parts list at the end of this manual lists replacement parts and accessories for the hydrogen detector.

---

## Specifications

---

**WARNING:** *Do not use this product in a manner not specified in this instruction manual.*

---

Table 1 lists specifications for the hydrogen detector.

**Table 1: 61-1001RKSS Specifications**

Description	Specifications
Target Gas	Hydrogen
Area Classification	Explosion proof for Class I, Groups B, C, and D
Sampling Method	Diffusion
Detection Range	0 to 100 %LEL
Response Time	90% in 45 seconds
Accuracy	± 5% of reading or ± 2% LEL (whichever is greater)

---

**WARNING:** *When using the 61-1001RKSS, you must follow the instructions and warnings in this manual to assure proper and safe operation of the 61-1001RKSS and to minimize the risk of personal injury. Be sure to maintain and periodically calibrate the 61-1001RKSS as described in this manual.*

---

## Description

This section describes the components of the NC-6205-01 and 61-1001RKSS detectors. The 61-1001RKSS includes the NC-6205-01 hydrogen detector and a junction box. A four point terminal strip is provided inside the junction box for detector connections.

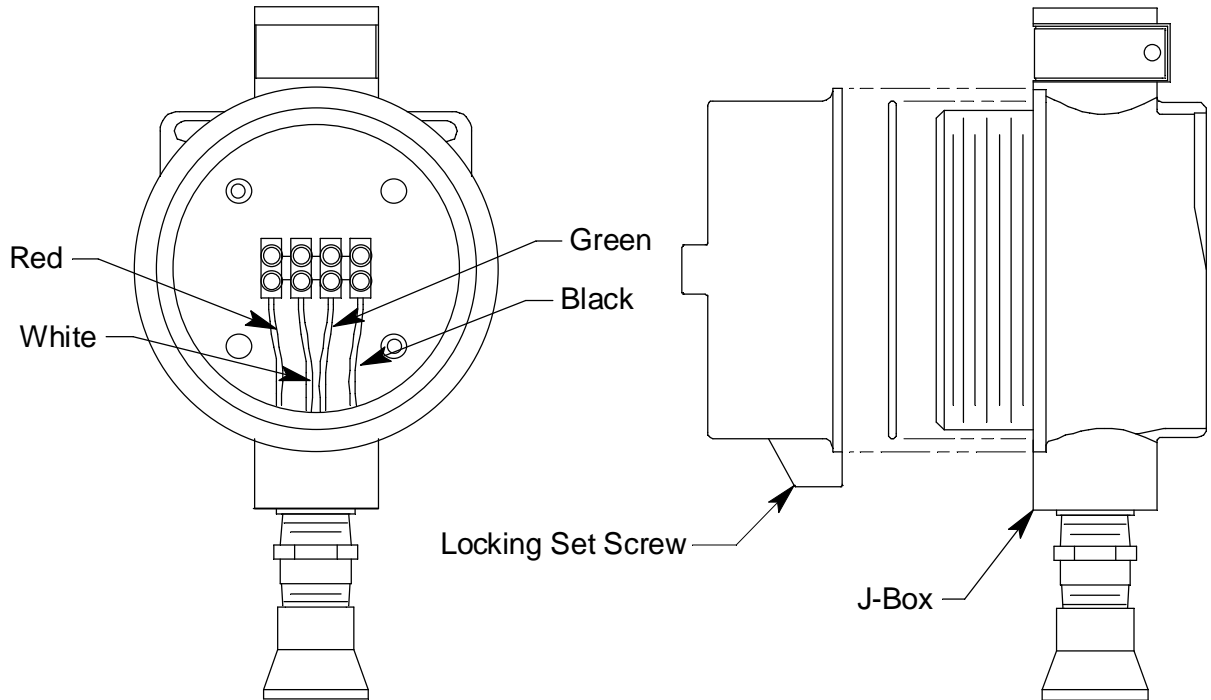

**Figure 1: 61-1001RKSS Component Location**

### NC-6205-01 Hydrogen Detector

The hydrogen detector is a catalytic type detector that produces an electrical output that corresponds to the detection range. It is packaged in a 1/2 inch NPT nipple with a sintered metal flame arrestor on one end allowing ambient air to diffuse into the detector. The flame arrestor also contains any sparks which may occur within the detector. The detector has a built in molecular sieve that only allows hydrogen to diffuse into the detector. The 1/2 inch NPT mounting threads at the top of the detector allow you to mount it into the bottom conduit hub of the junction box. The controller conduit hubs are normally 3/4 in. NPT, so a 3/4 in. x 1/2 in. NPT reducer may be necessary to install the hydrogen detector. A rainshield screws onto the bottom of the detector (flame arrestor end). The rainshield helps protect the detector from rain and debris in the monitoring environment. Four color-coded leads extend from the top of the detector. The leads allow you to connect the detector to the terminal block.

### Junction Box

The stainless steel, corrosion resistant junction box allows you to install the detector at a mounting site that is remote from a controller, and it protects the detector wiring connections. Two conduit hubs allow you to mount the detector to the junction box and connect the wiring from the detector to a controller. An O-ring seals the interface between the junction box cover and the junction box base.

The bottom conduit hub includes a 3/4 in. x 1/2 in. NPT reducer that allows you to screw the detector into the hub. The terminal block within the junction box facilitates the wiring process. A cover on the front of the junction box allows access to the interior of the

junction box. A locking set screw on the junction box cover allows you to secure the junction box cover and prevent it from being removed.

## Installation

This section describes procedures to mount the hydrogen detector in the monitoring environment and wire the detector to a controller.

### Mounting the Hydrogen Detector

1. Select a mounting site that is representative of the monitoring environment. Consider the following when you select the mounting site.
  - Select a site where the detector is not likely to be bumped or disturbed. Make sure there is sufficient room to perform start-up, maintenance, and calibration procedures.
  - Select a site where the target gas is likely to be found first. For hydrogen, which is lighter than air, mount the detector near the ceiling or where hydrogen is most likely to accumulate.

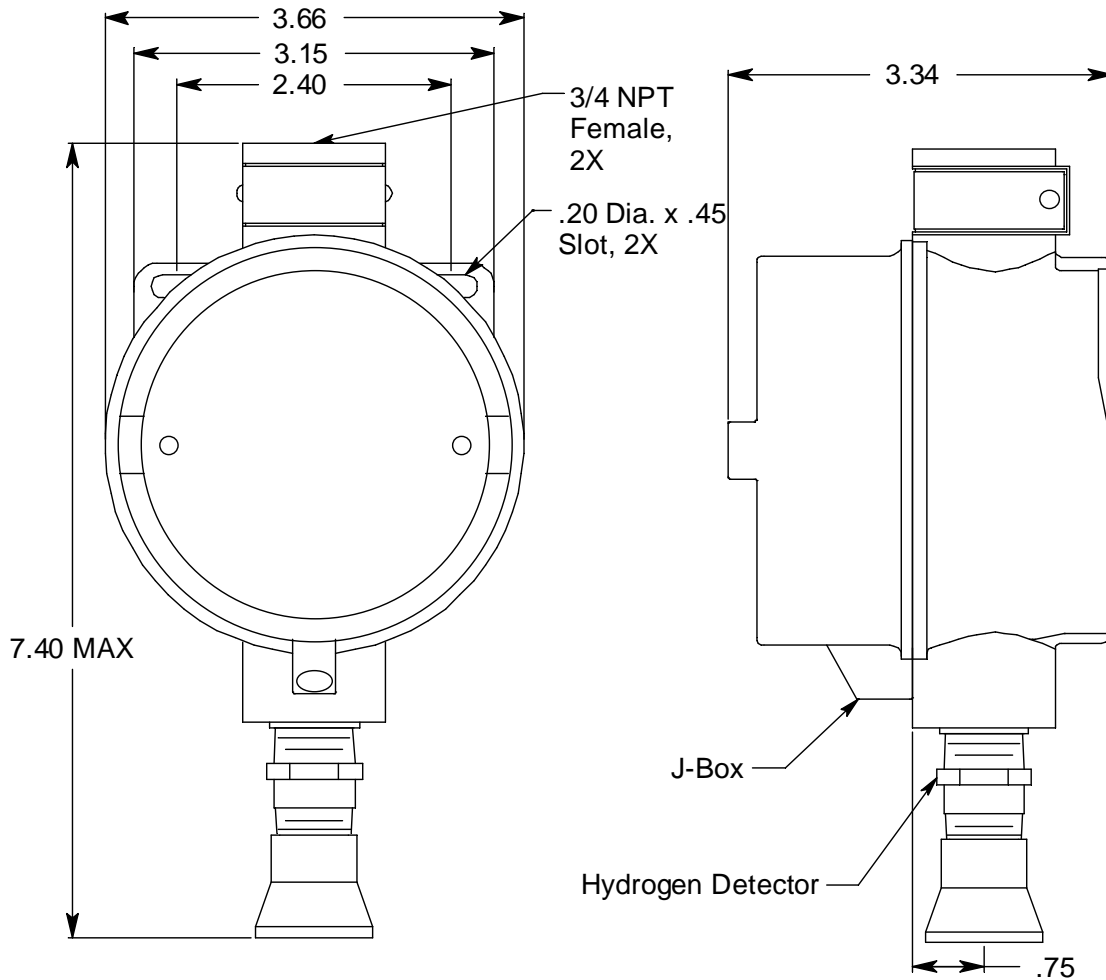

**Figure 2: Mounting the Hydrogen Detector**

2. At the mounting site you select, hang or mount the junction box with the detector facing down (see Figure 2).

## Wiring the Hydrogen Detector to a Controller

---

**WARNING:** *Always verify that the power to the controller is off before you make wiring connections.*

---

1. Turn off the controller.
2. Turn off power to the controller.
3. Remove the junction box cover.
4. Guide a four-conductor, shielded cable or four wires in conduit through the unused conduit hub of the junction box. Use appropriate conduit fittings and construction technique for the environmental rating and hazardous location classification of the junction box. The junction box is rated NEMA 4X and classified explosion proof for Class I, Groups B, C, and D.
5. Connect the detector leads to the terminal block in the junction box.

---

**CAUTION:** *If using shielded cable, leave the drain wire insulated and disconnected at the detector. You will connect the opposite end of the cable's drain wire at the controller.*

---

6. Secure the junction box cover to the junction box.
7. Route the cable or wires leading from the hydrogen detector through one of the conduit hubs at the controller housing. Use appropriate conduit fittings and construction technique for the environmental rating of the controller. RKI controllers are typically rated NEMA 4X.

---

**CAUTION:** *Do not route power and detector wiring through the same conduit hub. The power cable may disrupt the transmission of the detector signal to the controller.*

---

8. Connect the wires to the applicable controller terminal strip. See the controller operator's manual and the controller's detector head specification sheet for the 61-1001RKSS detector.
9. If using shielded cable, connect the cable's drain wire to an available chassis ground at the controller. RKI controllers typically have a ground stud that is a convenient grounding location.



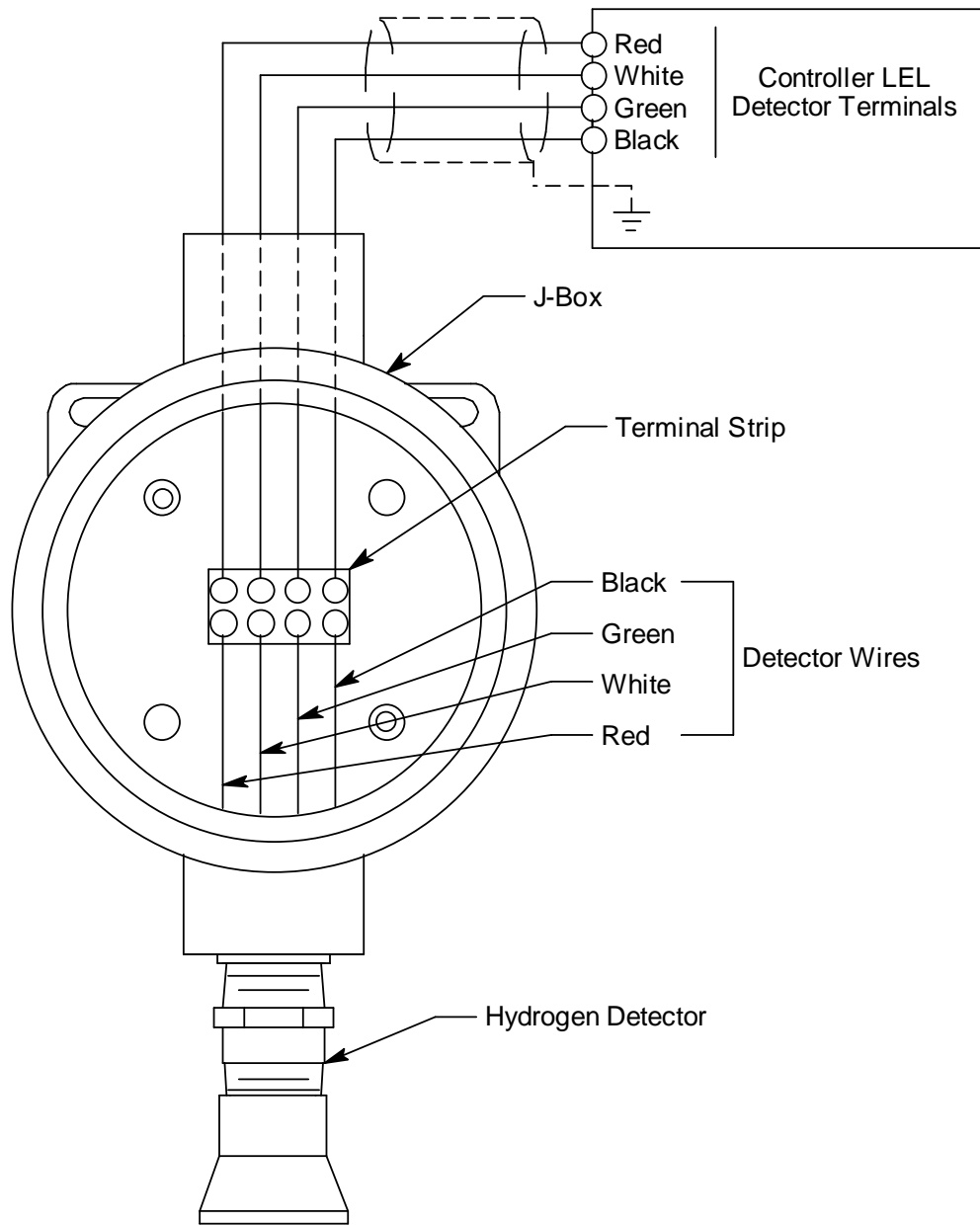

**Figure 3: Wiring the Hydrogen Detector to a Controller**

---

## Start Up

This section describes procedures to start up the hydrogen detector and place the detector into normal operation.

### Introducing Incoming Power

1. Complete the installation procedures described earlier in this manual.
2. Verify that the power wiring to the controller is correct and secure. Refer to the controller operator's manual.
3. Turn on power to the controller.
4. Turn on the controller.
5. Verify that the controller is on and operating properly. Refer to the controller operator's manual.

---

**CAUTION:** *Allow the detector to warm up for 5 minutes before you continue with the next section, "Setting the Zero Reading".*

---

### Setting the Zero Reading

---

**WARNING:** *Do not remove the junction box cover while the circuits are energized unless the area is determined to be non-hazardous. Keep the junction box cover tightly closed during operation.*

---

---

**CAUTION:** *If you suspect the presence of hydrogen in the monitoring environment, use the zero air calibration cylinder to introduce "fresh air" to the detector and verify an accurate zero reading.*

---

1. Verify that the detector is in a fresh air environment (environment known to be free of hydrogen and of normal oxygen concentration, 20.9%).
2. Verify a reading of 0% LEL at the controller.  
If the display reading is 0% LEL, start up is complete. The hydrogen detector is in normal operation. If the display reading is not 0% LEL, continue with step 3.
3. Perform a zeroing operation at the controller. See the controller operator's manual for directions.

---

## Maintenance

This section describes maintenance procedures. It includes preventive maintenance, troubleshooting, and component replacement procedures.

### Preventive Maintenance

This section describes a preventive maintenance schedule to ensure the optimum performance of the hydrogen detector. It includes daily, monthly, and quarterly procedures.

#### *Daily*

Verify a display reading of 0% LEL at the controller. Investigate significant changes in the reading.

#### *Monthly*

This procedure describes a test to verify that the hydrogen detector responds properly to the target gas.

---

**WARNING:** *The controller is not an active gas monitoring device during the response test procedure.*

---

---

**NOTE:** Performing a response test on the hydrogen detector may cause alarms. Be sure to put the controller into its calibration program or disable external alarms before performing this test.

---

---

**NOTE:** The following procedure assumes the use of a calibration kit which includes a calibration gas cylinder, a 0.5 LPM fixed flow regulator with an on/off knob, a calibration cup for the detector, and a length of sample tubing.

---

#### Preparing for the response test

1. Place the controller into its calibration program or disable external alarms.
2. Verify that the controller display reading is 0% LEL.  
If the controller reading is not 0% LEL, set the zero reading then continue this procedure. See the controller operator's manual for directions to set the zero reading.
3. Screw the regulator into the calibration cylinder.
4. Screw the calibration cup onto the bottom of the detector.
5. Use the calibration kit sample tubing to connect the regulator to the calibration cup.

#### Performing the response test

1. Turn the regulator's on/off knob counterclockwise to open the regulator. Gas will begin to flow.
2. Allow the gas to flow for one minute.

- Verify that the reading is within  $\pm 20\%$  of the gas concentration.

---

**NOTE:** If the readings are not within  $\pm 20\%$  of the gas concentration, calibrate the detector as described in the Calibration section of this manual.

---

- Turn the regulator knob clockwise to close the regulator.
- Unscrew the regulator from the calibration cylinder.
- Unscrew the calibration cup from the detector.
- When the display reading falls below the alarm setpoints, return the controller to normal operation.
- Store the components of the calibration kit in a safe place.

#### **Quarterly**

Calibrate the detector as described in the Calibration section of this manual.

### **Troubleshooting**

The troubleshooting guide describes symptoms, probable causes, and recommended action for problems you may encounter with the hydrogen detector.

---

**NOTE:** This troubleshooting guide describes detector problems only. See the controller operator's manual for problems you may encounter with the controller.

---

**Table 2: Troubleshooting the Hydrogen Detector**

<b>Condition</b>	<b>Symptom(s)</b>	<b>Probable Causes</b>	<b>Recommended Action</b>
Fail Condition	<ul style="list-style-type: none"> <li>Controller indicates a fail condition.</li> </ul>	<ul style="list-style-type: none"> <li>The detector wiring is disconnected or misconnected.</li> <li>The detector zero signal is low enough to cause a fail condition.</li> <li>The detector is malfunctioning.</li> </ul>	<ol style="list-style-type: none"> <li>Verify that the detector wiring is correct and secure.</li> <li>Calibrate the detector.</li> <li>If the fail condition continues, replace the detector.</li> <li>If the fail condition continues, contact RKI for further instruction.</li> </ol>
Slow or No Response/ Difficult or Unable to Calibrate	<ul style="list-style-type: none"> <li>Detector responds slowly or does not respond to response test.</li> <li>Unable to accurately set the zero or response reading during calibration.</li> <li>Detector requires frequent calibration.</li> </ul> <p><i>Note: Under "normal" circumstances, the detector requires calibration once every three months. Some applications may require a more frequent calibration schedule.</i></p>	<ul style="list-style-type: none"> <li>The calibration cylinder is low, out-dated, or defective.</li> <li>The calibration gas is not an appropriate concentration.</li> <li>The detector is malfunctioning.</li> </ul>	<ol style="list-style-type: none"> <li>Verify that the calibration cylinder contains an adequate supply of a fresh test sample.</li> <li>Verify that the calibration gas concentration is appropriate for the detector.</li> <li>If the calibration/response difficulties continue, replace the detector.</li> <li>If the calibration/response difficulties continue, contact RKI for further instruction.</li> </ol>

## Replacing the Hydrogen Detector

1. Turn off the controller.
2. Turn off power to the controller.
3. Remove the junction box cover.
4. Disconnect the detector leads from the terminal block in the junction box. Note the position of the color-coded leads as you remove them.
5. Unscrew the detector from the controller conduit hub or junction box conduit hub.
6. Guide the detector leads of the replacement detector through the controller conduit hub or junction box conduit hub, then screw the mounting threads of the detector into the hub. If necessary for environmental conditions, apply thread sealant or Teflon tape to the hub and/or detector threads to seal them.
7. Connect the detector leads to the terminal block the same way the old detector was wired (see Figure 3). See the controller operator's manual and the controller's detector head specification sheet for the 61-1001RKSS detector to verify the connections to the controller are correct.
8. Reinstall the junction box cover.
9. Turn on or plug in power to the controller.
10. Turn on the controller and place into normal operation.

---

**CAUTION:** *Allow the replacement detector to warm up for 5 minutes before you continue with the next step.*

---

11. Calibrate the replacement detector as described in the Calibration section of this manual.

---

## Calibration Frequency

Although there is no particular calibration frequency that is correct for all applications, a calibration frequency of every 3 to 6 months is adequate for most hydrogen detector applications. Unless experience in a particular application dictates otherwise, RKI Instruments, Inc. recommends a calibration frequency of every 3 months.

If an application is not very demanding, for example detection in a clean, temperature controlled environment where hydrogen is not normally present and calibration adjustments are minimal at calibration, then a calibration frequency of every 6 months is adequate.

If an application is very demanding, for example if hydrogen is present often and in significant concentrations or the environment is not well controlled, then more frequent calibration than every 3 months may be necessary. If potential catalyst poisons are known or likely to be present, more frequent calibration than every 3 months will be necessary.

---

## Calibration

This section describes how to calibrate the hydrogen detector. It includes procedures to prepare for calibration, set the zero reading, set the response reading, and return to normal operation.

---

**WARNING:** *The controller is not an active gas monitoring device during the calibration procedure.*

---

---

**NOTE:** The following procedure assumes the use of a calibration kit which includes a calibration gas cylinder, a 0.5 LPM fixed flow regulator with an on/off knob, a calibration cup for the detector, and a short piece of sample tubing to connect the regulator to the calibration cup.

---

### Preparing for Calibration

1. Screw the calibration cup onto the bottom of the detector.
2. Screw the regulator into the calibration cylinder.
3. Use the calibration kit sample tubing to connect the regulator to the calibration cup.
4. Place the controller into its calibration program or disable external alarms.

---

**NOTE:** Calibrating the hydrogen detector may cause alarms. Be sure to put the controller into its calibration program or disable external alarms before continuing.

---

### Setting the Zero Reading

---

**NOTE:** If you can verify that the hydrogen detector is in a fresh air environment, you do not need to apply zero air to the detector before adjusting the zero reading.

---

1. Follow the directions in the controller operator's manual for setting the zero reading.
2. When the instructions call for applying zero air to the detector, turn the regulator's on/off knob counterclockwise to open it.
3. Allow the gas to flow for one minute.
4. Set the zero reading according to the controller operator's manual.
5. Turn the regulator's on/off knob clockwise to close it.
6. Leave the sample tubing connected to the regulator and the calibration cup.

### Setting the Response Reading

1. Follow the directions in the controller operator's manual for setting the response reading (span).
2. When the directions call for exposing the detector to gas, turn the regulator's on/off knob counterclockwise to open it.
3. Allow the gas to flow for one minute before continuing with the directions.
4. After setting the response reading, turn the regulator's on/off knob clockwise to close it.

5. Unscrew the regulator from the cylinder.

### Returning to Normal Operation

1. Unscrew the calibration cup from the detector.

---

**NOTE:** For convenience, leave regulator and calibration cup connected by the sample tubing.

---

2. When the controller display reading falls below the alarm points, return the controller to normal operation.

---

**NOTE:** If you do not allow the gas reading to decrease below the alarm points, then unwanted alarms may occur.

---

3. Verify that the controller display reading decreases and stabilizes at 0 %LEL.
4. Store the components of the calibration kit in a safe and convenient place.

---

## Parts List

Table 3 lists replacement parts and accessories for the 61-1001RKSS hydrogen detector.

**Table 3: Parts List**

Part Number	Description
07-7151RK	O-ring
10-5153RK	Lid locking set screw
18-0416RK-11	Junction box with cover, stainless steel
71-0229RK	<i>61-1001RKSS Hydrogen Detector Operator's Manual</i> (this document)
81-0002RK-01	Calibration cylinder, 50 %LEL hydrogen in air, 34 liter steel
81-0076RK-01	Zero air calibration cylinder, 34 liter steel
81-1050RK	Regulator, 0.5 LPM with pressure gauge and flow control knob, for 17 liter and 34 liter steel calibration cylinders (cylinders with external threads)
81-1117RK	Calibration cup
NC-6205-01	Hydrogen detector