



**INSTRUMENTS**

**65-2427RK-05**  
**Hydrogen Sulfide Detector**  
**Operator's Manual**

*Part Number: 71-0227RK*

*Revision: C*

*Released: 6/15/20*

## **WARNING**

Read and understand this instruction manual before operating instrument. Improper use of the detector could result in bodily harm or death.

Periodic calibration and maintenance of the detector is essential for proper operation and correct readings. Please calibrate and maintain this detector regularly! Frequency of calibration depends upon the type of use you have and the sensor types. Typical calibration frequencies for most applications are between 3 and 6 months, but can be required more often or less often based on your usage.

---

## Product Warranty

RKI Instruments, Inc. warrants gas alarm equipment sold by us to be free from defects in materials, workmanship, and performance for a period of one year from date of shipment from RKI Instruments, Inc. Any parts found defective within that period will be repaired or replaced, at our option, free of charge. This warranty does not apply to those items which by their nature are subject to deterioration or consumption in normal service, and which must be cleaned, repaired, or replaced on a routine basis. Examples of such items are:

- a) Absorbent cartridges
- b) Pump diaphragms and valves
- c) Fuses
- d) Batteries
- e) Filter elements

Warranty is voided by abuse including mechanical damage, alteration, rough handling, or repair procedures not in accordance with the operator's manual. This warranty indicates the full extent of our liability, and we are not responsible for removal or replacement costs, local repair costs, transportation costs, or contingent expenses incurred without our prior approval.

*THIS WARRANTY IS EXPRESSLY IN LIEU OF ANY AND ALL OTHER WARRANTIES AND REPRESENTATIONS, EXPRESSED OR IMPLIED, AND ALL OTHER OBLIGATIONS OR LIABILITIES ON THE PART OF RKI INSTRUMENTS, INC. INCLUDING BUT NOT LIMITED TO, THE WARRANTY OF MERCHANTABILITY OR FITNESS FOR A PARTICULAR PURPOSE. IN NO EVENT SHALL RKI INSTRUMENTS, INC. BE LIABLE FOR INDIRECT, INCIDENTAL, OR CONSEQUENTIAL LOSS OR DAMAGE OF ANY KIND CONNECTED WITH THE USE OF ITS PRODUCTS OR FAILURE OF ITS PRODUCTS TO FUNCTION OR OPERATE PROPERLY.*

This warranty covers instruments and parts sold to users by authorized distributors, dealers, and representatives as appointed by RKI Instruments, Inc.

We do not assume indemnification for any accident or damage caused by the operation of this gas monitor, and our warranty is limited to the replacement of parts or our complete goods.

---

## Table of Contents

<b>Overview</b> .....	<b>5</b>
<b>Specifications</b> .....	<b>5</b>
<b>Description</b> .....	<b>6</b>
H <sub>2</sub> S Detector .....	7
Junction Box .....	8
<b>Installation</b> .....	<b>8</b>
Mounting the H <sub>2</sub> S Detector .....	8
Wiring the H <sub>2</sub> S Detector to a Controller .....	10
<b>Startup</b> .....	<b>12</b>
Introducing Incoming Power .....	12
Setting the Zero Signal .....	12
<b>Maintenance</b> .....	<b>13</b>
Preventive Maintenance .....	13
Troubleshooting .....	13
Replacing Components of the H <sub>2</sub> S Detector .....	14
<b>Calibration</b> .....	<b>16</b>
Preparing for Calibration .....	16
Setting the Zero Reading .....	17
Setting the Span Reading .....	17
Returning to Normal Operation .....	18
<b>Parts List</b> .....	<b>18</b>

---

## Overview

This manual describes the 65-2427RK-05 hydrogen sulfide (H<sub>2</sub>S) detector. This manual also describes how to install, start up, maintain, and calibrate the detector when it is used with a gas monitoring controller. A parts list at the end of this manual lists replacement parts and accessories for the H<sub>2</sub>S detector.

---

## Specifications

---

**WARNING: Do not use this product in a manner not specified in this instruction manual.**

---

Table 1 lists specifications for the H<sub>2</sub>S detector.

**Table 1: Specifications**

<b>Target Gas</b>	Hydrogen sulfide (H <sub>2</sub> S)
<b>Area Classification</b>	Explosionproof for Class I, Groups B, C, and D
<b>Temperature Code</b>	T6
<b>Installation Category</b>	Installation Category 1. Signal level, special equipment or parts of equipment, telecommunication, electronic, etc., with smaller transient overvoltages than Installation Category (Overvoltage Category) II (ref. IEC 664).
<b>Sampling Method</b>	Diffusion
<b>Detection Range</b>	0 to 100 PPM (parts per million)
<b>H<sub>2</sub>S Detector Signal Output</b>	0.3 mA at 0 ppm H <sub>2</sub> S nominal 2.5 mA at 100 ppm H <sub>2</sub> S nominal
<b>Response Time</b>	90% in 30 seconds
<b>Accuracy</b>	± 5% of reading or ± 2 ppm H <sub>2</sub> S (whichever is greater)
<b>Operating Temperature</b>	-40°F to 104°F (-40°C to 40°C)

---

**NOTE:** The following symbol on the detector label is a caution to the user to refer to this documentation for installation and operation instructions: 

---

---

**WARNING: When using the 65-2427RK-05, you must follow the instructions and warnings in this manual to assure proper and safe operation of the 65-2427RK-05 and to minimize the risk of personal injury. Be sure to maintain and periodically calibrate the 65-2427RK-05 as described in this manual.**

---

## Description

This section describes the components of the 65-2427RK-05 H<sub>2</sub>S detector. The 65-2427RK-05 consists of the 65-2428 H<sub>2</sub>S detector and junction box.

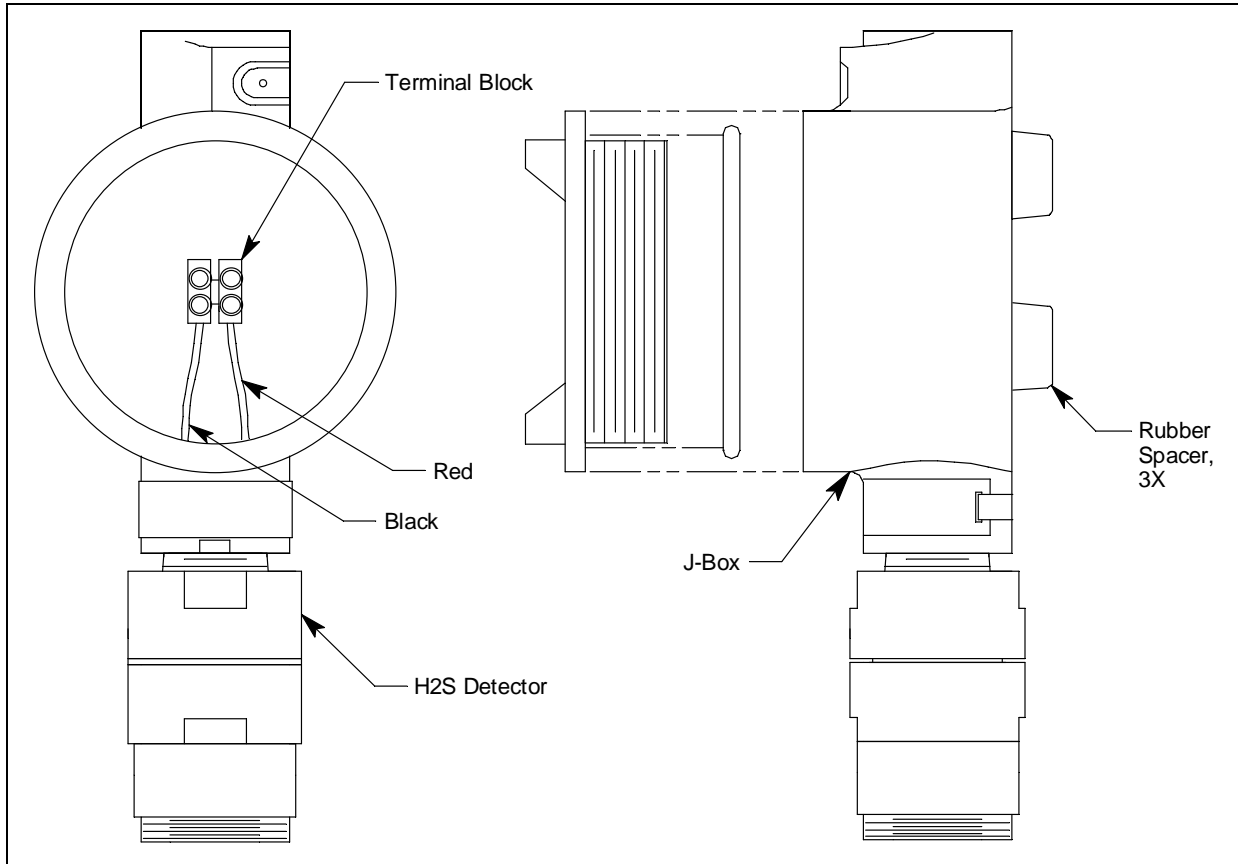

**Figure 1: H<sub>2</sub>S Detector Component Location**

## 65-2428 H<sub>2</sub>S Detector

The 65-2428 H<sub>2</sub>S detector consists of the detector housing body, detector housing cap, cap gasket, rubber boot, spacer, and the plug-in sensor.

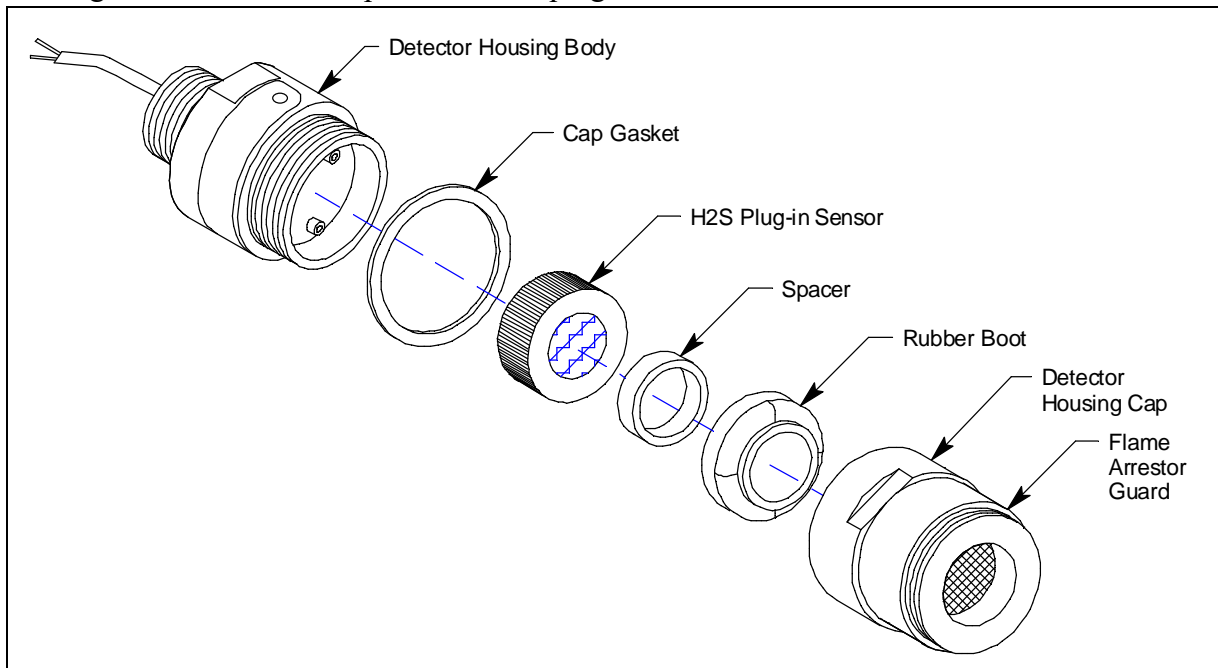

Figure 2: H<sub>2</sub>S Detector Component Location

### ***Detector Housing Body, Housing Cap, & Cap Gasket***

The detector housing body protects the sensing components within the housing. Use the 3/4" NPT mounting threads at the top of the housing to screw the H<sub>2</sub>S detector into the bottom conduit hubs of the junction box. Use the removable cap near the bottom of the housing to access the sensor for maintenance or replacement. The cap protects the sensor from damage and includes a flame arrester which contains any sparks which may occur within the detector housing. A cap gasket seals the interface between the housing and cap. A flame arrester guard is permanently bonded to the cap.

Two wires extend from the top of the detector housing body. Use these wires to connect the H<sub>2</sub>S detector to the junction box terminal strip. The housing includes a four-socket pattern. This socket pattern accepts the sensor's four pins to secure the sensor within the detector housing. A pre-amplifier, located between the sockets and two interconnect wires, conditions the sensor's signal before the signal reaches the controller.

### ***Rubber Boot and Spacer***

A rubber boot and spacer are installed between the detector housing cap and the sensor. They help ensure that the detector remains plugged into the detector housing body.

### ***Plug-In Sensor***

The sensor is secured within the sensor housing by four pins. Through a series of chemical and electrical reactions, the sensor produces an electrical output that corresponds to the detection range of the detector.

### **Junction Box**

The junction box allows you to install the detector at a mounting site that is remote from a controller, and it protects the detector wiring connections. Two conduit hubs allow you to mount the detector to the junction box and connect the wiring from the detector to a controller. Three spacers installed on the back of the junction box control the distance of the junction box from a mounting surface and ensure that there is enough room to install a calibration cup on the detector during calibration. The terminal block within the junction box facilitates the wiring process. A cover on the front of the junction box allows access to the interior of the junction box.

---

## **Installation**

This section describes procedures to mount the H<sub>2</sub>S detector in the monitoring environment and wire the detector to a controller.

### **Mounting the H<sub>2</sub>S Detector**

1. Select a mounting site that is representative of the monitoring environment. Consider the following when you select the mounting site.
  - Select a site where the detector is not likely to be bumped or disturbed. Make sure there is sufficient room to perform start-up, maintenance, and calibration procedures.
  - Select a site where the target gas is likely to be found first.

---

**NOTE:** If your application does not require a specific mounting site, mount the detector at approximately breathing level.

---



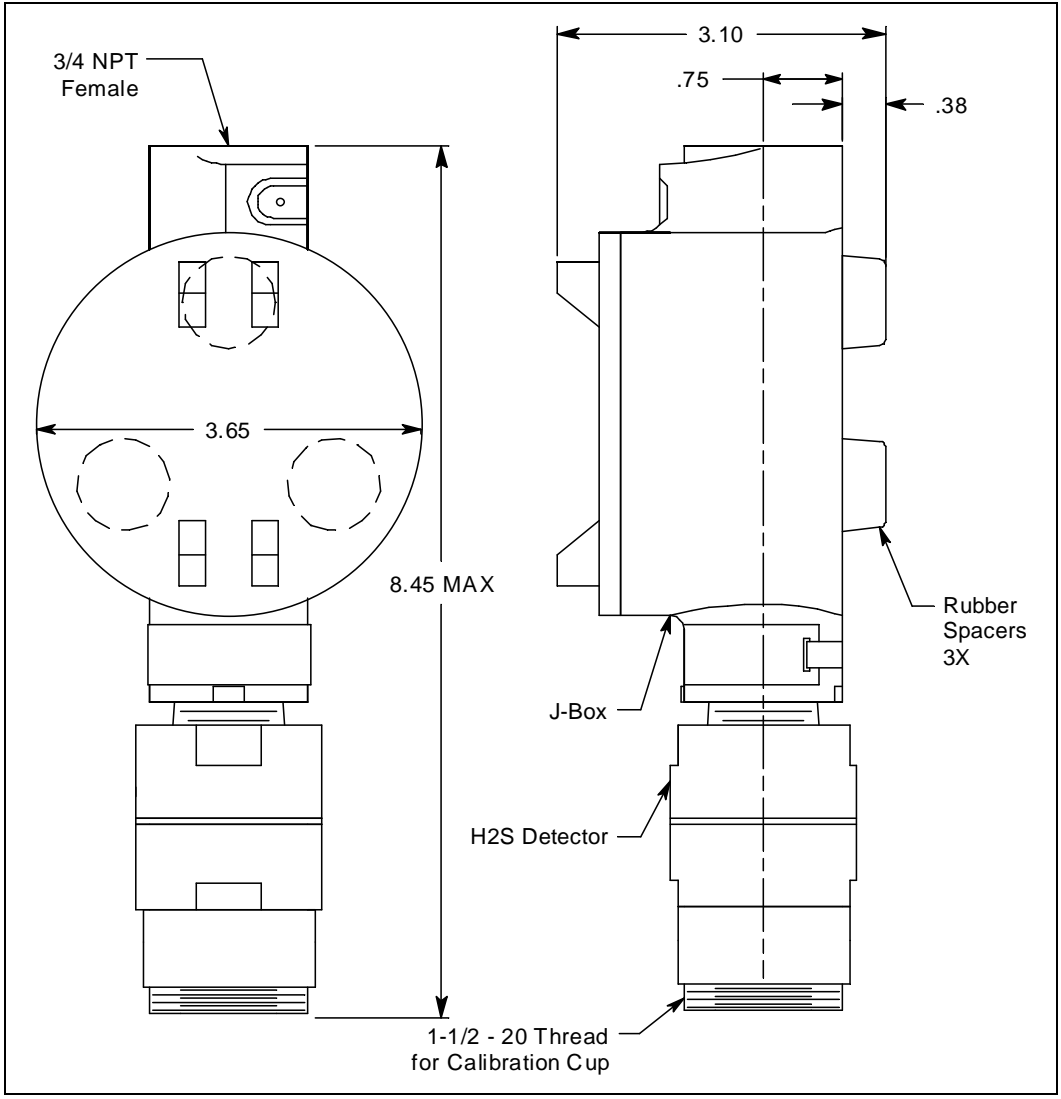

**Figure 3: Outline & Mounting Dimensions**

2. At the monitoring site you select, hang or mount the junction box with the detector facing down (see Figure 3).

## Wiring the H<sub>2</sub>S Detector to a Controller

---

**WARNING:** *Always verify that the power source is OFF before you make wiring connections.*

---

1. Turn off the controller.
2. Turn off or unplug power to the controller.
3. Remove the junction box cover.

---

**WARNING:** *To maintain the explosion proof classification of the H<sub>2</sub>S detector, a conduit seal must be used within 2 inches of the junction box conduit hub used for wiring to the controller.*

---

4. Guide a two-conductor, shielded cable or two wires in conduit through an unused conduit hub of the junction box. Use appropriate conduit fittings and construction technique for the environmental and hazardous location rating of the junction box. The junction box is rated NEMA 4X and Class 1, Division 1, Groups B, C, D.
5. Connect the two wires to the detector using the 2 point terminal block.

---

**CAUTION:** *If using shielded cable, leave the drain wire insulated and disconnected at the detector. You will connect the opposite end of the cable's drain wire at the controller.*

---

6. Secure the junction box cover to the junction box.
7. Route the cable or wires leading from the H<sub>2</sub>S detector through one of the conduit hubs at the controller housing. Use appropriate conduit fittings and construction technique for the environmental rating of the controller. RKI controllers are typically rated NEMA 4X.

---

**CAUTION:** *Do not route power and detector wiring through the same conduit hub. The power cable may disrupt the transmission of the detector signal to the controller.*

---

8. Connect the wires to the applicable controller terminal strip. See the controller operator's manual and the controller's detector head specification sheet.

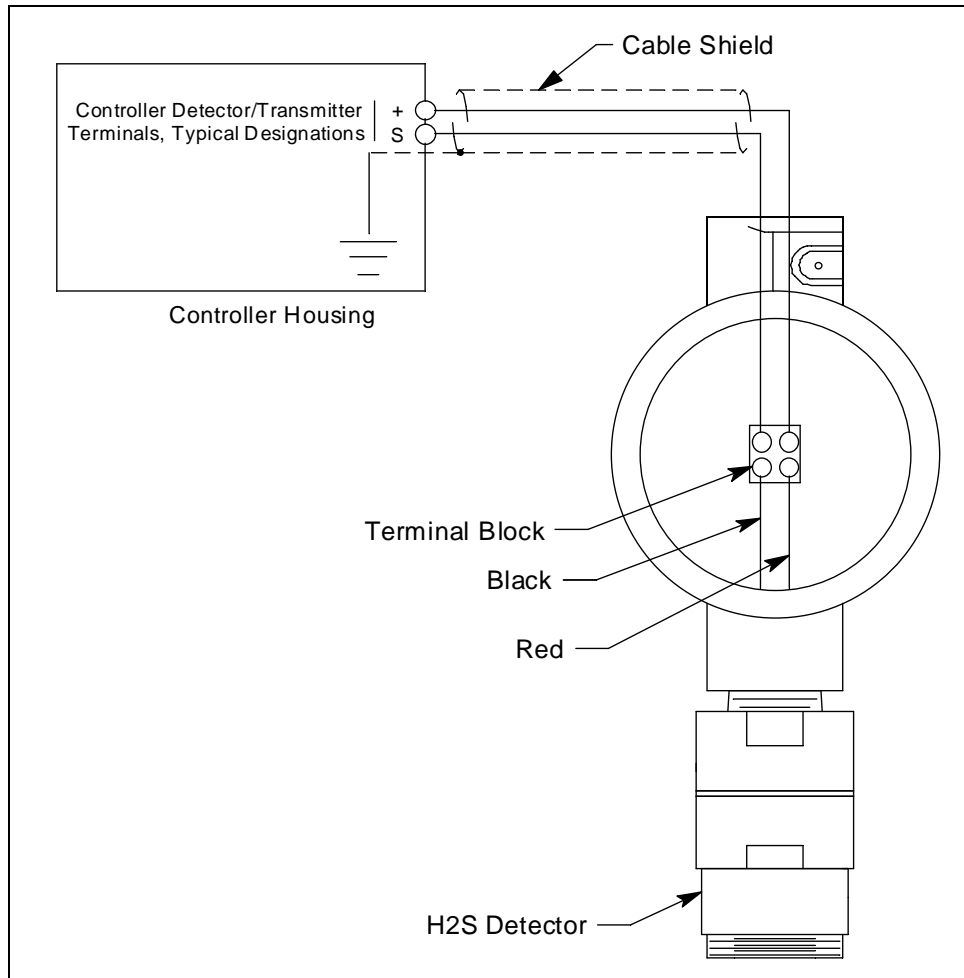

**Figure 4: Wiring the H<sub>2</sub>S Detector to a Controller**

9. If using shielded cable, connect the cable's drain wire to an available chassis ground at the controller. RKI controllers typically have a ground stud that is a convenient grounding location.
10. Reinstall the junction box cover.

---

## Start Up

This section describes procedures to start up the H<sub>2</sub>S detector and place the detector into normal operation.

### Introducing Incoming Power

1. Complete the installation procedures described earlier in this manual.
2. Verify that the power wiring to the controller is correct and secure. Refer to the controller operator's manual.
3. Turn on power to the controller.
4. Turn on the controller.
5. Verify that the controller is on and operating properly. Refer to the controller operator's manual.

---

**CAUTION:** Allow the detector to warm up for 5 minutes before you continue with the next section, "Setting the Zero (Fresh Air) Reading".

---

### Setting the Zero (Fresh Air) Reading

---

**WARNING:** If the detector installation is explosion proof, do not remove the detector housing cap or junction box cover while the circuits are energized unless the area is determined to be non-hazardous. Keep the detector housing cap and junction box cover tightly closed during operation.

---

---

**CAUTION:** If you suspect the presence of H<sub>2</sub>S in the monitoring environment, use the calibration kit and a zero air calibration cylinder to introduce "fresh air" to the H<sub>2</sub>S detector and verify an accurate zero setting. See "Calibration" on page 16 for instructions to introduce zero air to the H<sub>2</sub>S detector.

---

1. Verify that the detector is in a fresh air environment (environment known to be free of hydrogen sulfide, other toxic and combustible gases, and of normal oxygen content, 20.9%).
2. Verify a reading of 0 ppm H<sub>2</sub>S at the controller.  
  
If the display reading is 0 ppm H<sub>2</sub>S, start up is complete. The detector is in normal operation. If the display reading is not 0 ppm H<sub>2</sub>S, continue with step 3.
3. Perform a zeroing operation at the controller. See the controller operator's manual for directions.

---

## Maintenance

This section describes maintenance procedures. It includes preventive maintenance, troubleshooting, and component replacement procedures.

### Preventive Maintenance

This section describes a preventive maintenance schedule to ensure the optimum performance of the H<sub>2</sub>S detector. It includes daily and quarterly procedures.

#### Daily

Verify a display reading of 0 PPM H<sub>2</sub>S at the controller. Investigate significant changes in the display reading.

#### Quarterly

Calibrate the H<sub>2</sub>S detector as described in the Calibration section of this manual.

### Troubleshooting

The troubleshooting guide describes symptoms, probable causes, and recommended action for problems you may encounter with the H<sub>2</sub>S detector.

---

**NOTE:** This troubleshooting guide describes detector problems only. See the controller operator's manual for problems you may encounter with the controller.

---

**Table 2: Troubleshooting the H<sub>2</sub>S Detector**

Condition	Symptom(s)	Probable Causes	Recommended Action
Fail Condition	Controller indicates a fail condition.	<ul style="list-style-type: none"><li>The detector wiring is disconnected or misconnected.</li><li>The plug-in sensor is not properly plugged into the sockets in the detector housing body.</li><li>The detector's zero reading is low enough to cause a fail condition.</li><li>The detector is malfunctioning.</li></ul>	<ol style="list-style-type: none"><li>Verify that the detector wiring is correct and secure.</li><li>Confirm that the plug-in sensor is installed properly.</li><li>Perform a zero adjustment. A full calibration is recommended.</li><li>If the fail condition continues, replace the plug-in sensor as described later in this section.</li><li>If the fail condition continues, contact RKI for further instruction.</li></ol>

Condition	Symptom(s)	Probable Causes	Recommended Action
Slow or No Response/ Difficult or Unable to Calibrate	<ul style="list-style-type: none"> <li>• Detector responds slowly or does not respond during response test.</li> <li>• Unable to accurately set the zero or response reading during calibration.</li> <li>• Detector requires frequent calibration.</li> </ul> <p><i>Note: Under "normal" circumstances, the detector requires calibration once every 3 months. Some applications may require a more frequent calibration schedule.</i></p>	<ul style="list-style-type: none"> <li>• The calibration cylinder is low, out-dated, or defective.</li> <li>• The flame arrestor in the detector housing cap is wet or clogged with dirt or other particulates.</li> <li>• The calibration gas is not an appropriate concentration.</li> <li>• The detector is malfunctioning.</li> </ul>	<ol style="list-style-type: none"> <li>1. Verify that the calibration cylinder contains an adequate supply of a fresh test sample.</li> <li>2. Check the detector housing cap to determine if the flame arrestor is wet or dirty. Clean if necessary.</li> <li>3. Verify that the calibration gas concentration is appropriate for the detector. Zero emission air (20.9% oxygen) is normally used for a zero adjustment if the environment is suspect and 25 PPM H<sub>2</sub>S in nitrogen is normally used for a response adjustment.</li> <li>4. If the calibration/response difficulties continue, replace the plug-in sensor as described later in this section.</li> <li>5. If the calibration/response difficulties continue, contact RKI for further instruction.</li> </ol>

### Replacing Components of the H<sub>2</sub>S Detector

This section includes a procedure to replace the H<sub>2</sub>S sensor and the entire detector assembly. In most cases, it is not necessary to replace the entire detector assembly.

#### Replacing the Plug-In H<sub>2</sub>S Sensor

---

**CAUTION:** *The sensor contains electrolyte which is a dilute acid. Do not disassemble the sensor when replacing it with a new one. If sensor electrolyte comes in contact with your skin, wash affected area thoroughly with soap and water.*

---

1. Turn off the controller.
2. Turn off or unplug power to the controller.
3. Unscrew the detector housing cap from the detector housing body. Make sure not to lose the cap gasket.
4. Unplug and remove the H<sub>2</sub>S sensor with the rubber boot and spacer attached.
5. Remove the rubber boot and spacer from the old sensor.
6. Remove the replacement sensor from its packaging and remove the wire jumper. This wire jumper is installed on the sensor pins for shipment or storage but must be removed for the sensor to operate properly when installed in a detector.

---

**WARNING:** *The H<sub>2</sub>S sensor will not operate properly if the wire jumper is not removed.*

---

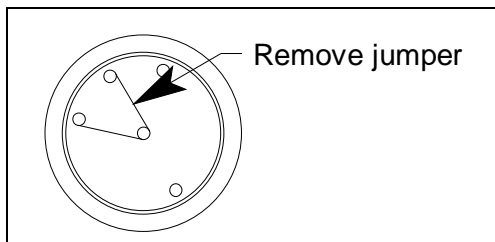

**Figure 5: Plug-In Sensor Jumper Removal**

7. Install the spacer and rubber boot onto the replacement sensor's face.
8. Carefully plug the replacement sensor into the four-socket pattern that is located in the detector housing.
9. Make sure the cap gasket is in place and screw the detector housing cap back onto the detector housing body.
10. Turn on or plug in power to the controller.
11. Turn on the controller and place into normal operation.

---

**CAUTION:** *Allow the replacement sensor to warm up for 5 minutes before you continue with the next step.*

---

12. Calibrate the replacement sensor as described in the Calibration section of this manual.

### **Replacing the H<sub>2</sub>S Detector**

---

**NOTE:** In most cases, it is only necessary to replace the H<sub>2</sub>S sensor.

---

1. Turn off the controller.
2. Turn off or unplug power to the controller.
3. Remove the junction box cover.
4. Disconnect the detector leads from the terminal block in the junction box. Note the position of the color-coded leads as you remove them.
5. Unscrew the detector from the junction box hub.
6. Guide the detector leads of the replacement detector through the junction box hub then screw the mounting threads of the detector into the hub.
7. Connect the detector leads to the terminal block the same way the old detector was wired. See the controller operator's manual and the controller's detector head specification sheet to verify the connections are correct.
8. Reinstall the junction box cover.

9. Turn on or plug in power to the controller.
10. Turn on the controller and place into normal operation.

---

**CAUTION:** Allow the replacement detector to warm up for 5 minutes before you continue with the next step.

---

11. Calibrate the replacement detector as described in the Calibration section of this manual.

---

## Calibration Frequency

Although there is no particular calibration frequency that is correct for all applications, a calibration frequency of every 3 months is adequate for most H<sub>2</sub>S detector applications. Unless experience in a particular application dictates otherwise, RKI Instruments, Inc. recommends a calibration frequency of every 3 months for the H<sub>2</sub>S detector.

If an application is not very demanding, for example detection in a clean, temperature controlled environment, and calibration adjustments are minimal at calibration, then a calibration frequency of every 6 months is adequate.

If an application is very demanding, for example if the environment is not well controlled, then more frequent calibration than every 3 months may be necessary.

---

## Calibration

This section describes how to calibrate the H<sub>2</sub>S detector. It includes procedures to prepare for calibration, set the zero reading, set the response reading, and return to normal operation. It describes calibration using a calibration kit that includes a calibration cup, calibration gas, sample tubing, and a fixed flow regulator with an on/off knob. RKI Instruments, Inc. recommends using a 0.5 LPM (liters per minute) fixed flow regulator.

### Preparing for Calibration

---

**NOTE:** Calibrating the H<sub>2</sub>S detector may cause alarms. Be sure to put the controller into its calibration program or disable external alarms before calibrating.

---

---

**WARNING:** Do not remove the detector housing cap while the circuits are energized unless the area is determined to be non-hazardous. Keep the detector housing cap tightly closed during operation.

---

1. Screw the calibration cup onto the bottom of the H<sub>2</sub>S detector.
2. Screw the regulator into the zero air calibration cylinder.
3. Use the calibration kit sample tubing to connect the fixed flow regulator to the calibration cup.



4. Put the controller into its calibration program.

### **Setting the Zero Reading**

---

**NOTE:** If you can verify that the H<sub>2</sub>S detector is in a fresh air environment, you do not need to apply zero air to the detector before adjusting the zero reading.

---

1. Follow the directions in the controller operator's manual for setting the zero reading.
  2. When the instructions call for applying zero air to the detector, turn the regulator's on/off knob counterclockwise to open it.
  3. Allow the gas to flow for two minutes.
  4. Set the zero reading according to the controller operator's manual.
  5. Turn the regulator's on/off knob clockwise to close it.
  6. Unscrew the regulator from the zero air calibration cylinder.
  7. Leave the sample tubing connected to the regulator and the calibration cup.
- 

**NOTE:** Depending on the size of your zero air cylinder, it is possible that you will have a different regulator for the zero air cylinder and the H<sub>2</sub>S gas cylinder. If necessary to fit the H<sub>2</sub>S calibration gas cylinder, change the regulator.

---

### **Setting the Span Reading**

1. Follow the directions in the controller operator's manual for setting the response reading (span).
  2. For toxic gas cylinders (like H<sub>2</sub>S), it is important to vent the regulator while installing it onto the cylinder. Venting the regulator during installation helps prevent air from getting into the cylinder and degrading the gas. When the directions call for exposing the detector to gas, open the regulator by turning the knob counterclockwise and then install it onto the cylinder.
  3. Allow gas to flow for 2 minutes.
  4. Set the response reading according to the controller operator's manual.
  5. After setting the response reading, turn the regulator's on/off knob clockwise to close it.
  6. Unscrew the regulator from the cylinder.
  7. Remove the calibration cup from the detector.
- 

**NOTE:** For convenience, leave regulator and calibration cup connected by the sample tubing.

---

## Returning to Normal Operation

1. Allow about 45 seconds for the gas reading to decrease below the alarm points and then return the controller to normal operation.

---

**NOTE:** If you do not allow the gas reading to decrease below the alarm points, then unwanted alarms may occur.

---

2. Verify that the controller display reading decreases and stabilizes at 0 ppm H<sub>2</sub>S.
3. Store the components of the calibration kit in a safe and convenient place.

---

## Parts List

Table 5 lists replacement parts and accessories for the H<sub>2</sub>S detector.

**Table 3: Parts List**

Part Number	Description
06-1248RK	Sample tubing (order by the foot)
07-0033RK	Detector housing cap gasket
07-0203RK	Rubber retaining boot
14-2101RK	Spacer between sensor and rubber boot
18-0400RK-01	Junction box with rubber spacers
65-2427RK-05	H <sub>2</sub> S detector/j-box, CSA classified
65-2428	H <sub>2</sub> S detector (with plug-in sensor)
71-0227RK	<i>65-2427RK-05 H<sub>2</sub>S Detector Operator's Manual (this document)</i>
81-0064RK-04	Calibration cylinder, 25 PPM H <sub>2</sub> S in nitrogen, 34 liter aluminum
81-0076RK	Zero air calibration cylinder, 17 liter
81-0076RK-01	Zero air calibration cylinder, 34 liter steel
81-0076RK-03	Zero air calibration cylinder, 103 liter
81-0151RK-02	Calibration cylinder, 25 PPM H <sub>2</sub> S in nitrogen, 58 liter
81-1050RK	Regulator with gauge and knob, 0.5 LPM, for 17 liter and 34 liter steel calibration cylinders (cylinders with external threads)
81-1051RK	Regulator with gauge and knob, 0.5 LPM, for 34 liter aluminum, 58 liter, and 103 liter calibration cylinders (cylinders with internal threads)
81-1117RK	Calibration cup
ES-1537-H2S	H <sub>2</sub> S replacement sensor