



INSTRUMENTS

**30-0954RK-250 Series Sample Draw
Aspirator Adapter
Operator's Manual**

Part Number: 71-0218RK

Revision: P1

Released: 11/3/10

Product Warranty

RKI Instruments, Inc. warrants gas alarm equipment sold by us to be free from defects in materials, workmanship, and performance for a period of one year from the date of shipment from RKI Instruments, Inc. Any parts found defective within that period will be repaired or replaced, at our option, free of charge. Parts must be returned to RKI Instruments, Inc. for repair or replacement. This warranty does not apply to those items which by their nature are subject to deterioration or consumption in normal service, and which must be cleaned, repaired or replaced on a routine basis. Examples of such items are:

- | | |
|-------------------------------|--------------------|
| a) Pump diaphragms and valves | c) Batteries |
| b) Fuses | d) Filter elements |

Warranty is voided by abuse including mechanical damage, alteration, rough handling, or repair procedures not in accordance with instruction manual. This warranty indicates the full extent of our liability, and we are not responsible for removal or replacement costs, local repair costs, transportation costs, or contingent expenses incurred without our prior approval.

THIS WARRANTY IS EXPRESSLY IN LIEU OF ANY AND ALL OTHER WARRANTIES AND REPRESENTATIONS, EXPRESSED OR IMPLIED, AND ALL OTHER OBLIGATIONS OR LIABILITIES ON THE PART OF RKI INSTRUMENTS, INC. INCLUDING BUT NOT LIMITED TO, THE WARRANTY OF MERCHANTABILITY OR FITNESS FOR A PARTICULAR PURPOSE. IN NO EVENT SHALL RKI INSTRUMENTS, INC. BE LIABLE FOR INDIRECT, INCIDENTAL OR CONSEQUENTIAL LOSS OR DAMAGE OF ANY KIND CONNECTED WITH THE USE OF ITS PRODUCTS OR FAILURE OF ITS PRODUCTS TO FUNCTION OR OPERATE PROPERLY.

This warranty covers instruments and parts sold to users only by authorized distributors, dealers and representatives as appointed by RKI Instruments, Inc.

We do not assume indemnification for any accident or damage caused by the operation of this gas monitor and our warranty is limited to the replacement of parts or our complete goods. Warranty covers parts and labor performed at RKI Instruments, Inc. only, and does not cover field labor or shipment of parts back to RKI.

Overview

This manual describes the 30-0954RK-250 Series sample draw aspirator adapter. It also describes how to install and use the adapter. A spare parts list at the end of this manual lists replacement parts.

Specifications

Table 1 lists specifications for the Sample Draw Aspirator Adapter.

Table 1: Specifications

Applicable Detector Heads	65-3050RK Detector/Transmitter
Maximum Compressed Air Supply Pressure	140 PSI
Outlet Pressure to Aspirator	5 - 50 PSI adjustable (determined by required flow rate)
Recommended Sample Flow Rate	3 SCFH (standard cubic feet per hour)

Description

The sample draw aspirator adapter uses compressed air flowing through a venturi to draw air into a sample chamber.

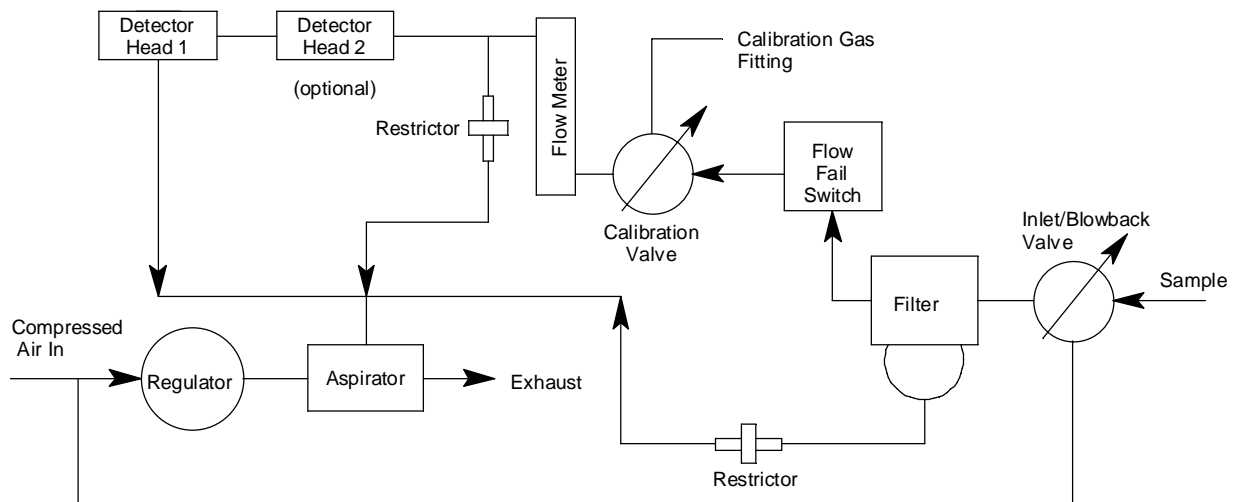

Figure 1: Flow Diagram

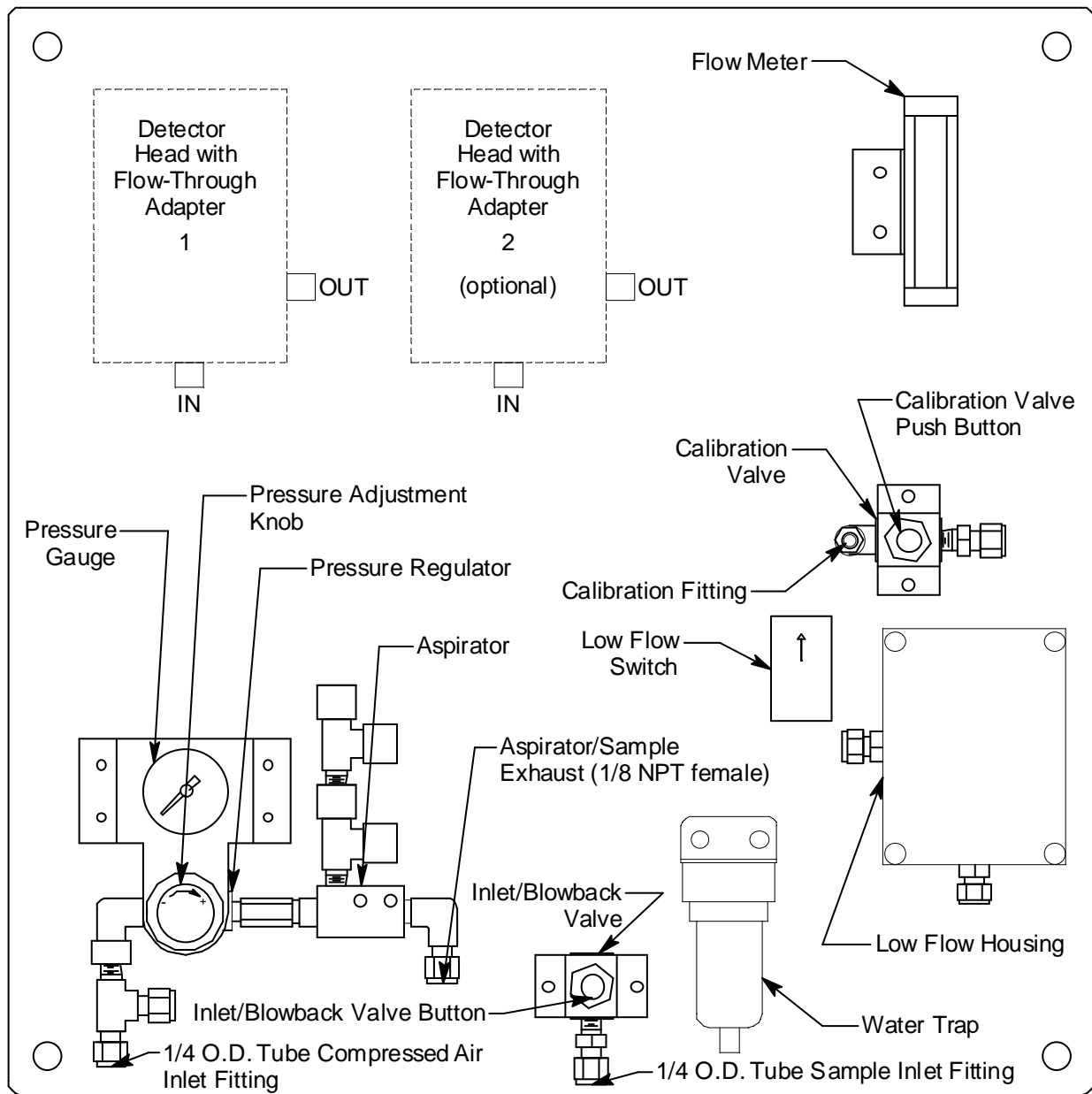

Figure 2: Component Location

The sample draw adapter consists of nine major components (see Figure 2): the detector head (1 or 2), regulator, aspirator, flow-through sample adapter (1 or 2), flowmeter, calibration valve, inlet/blowback valve, low flow switch, and low flow contact housing.

Detector Head(s)

Each detector head provides a signal that can be used by a controller to indicate the sample gas level. The 65-3050RK detector/transmitter is used with the 30-0954RK-250 sample drawing adapter plate. Figure 2 above shows the approximate location of the two detector heads. Please see the detector head operator's manual of the detector head(s) in your system for a complete description of the detector head(s).

Regulator

The regulator has an inlet port on its left side with a 1/4" tube fitting. The maximum allowable inlet pressure is 140 PSI. A gauge at the bottom of the regulator indicates the output pressure. The output pressure, and detector flow, can be adjusted using the knob on the front of the regulator. The detector flow rises or falls as the output pressure is increased or decreased.

Aspirator

The aspirator inlet is connected to the output port on the right side of the regulator and the vacuum port on top is connected to the detector chamber. It has a venturi tube inside it which generates a vacuum at its top port when compressed air flows through it. The compressed air and the air drawn from the flow-through sample adapter into the top port of the aspirator both exhaust at the right side of the aspirator.

Flow-Through Sample Adapter

The flow-through sample adapter is screwed into the detector adapter. The inlet of the flow-through sample adapter is on the bottom and is connected to one of the flowmeter's exhausts. The exhaust of the flow-through sample adapter is at the side and is connected to the vacuum port of the aspirator.

Flowmeter

The flowmeter indicates the flow to the detector(s). It has a 1/4" OD tube fitting at its inlet and exhaust port. The exhaust port splits into two sections in order to control the flow to the detector. One section has a restrictor and goes directly to the exhaust port. The other section goes to the detector chamber or to the first detector chamber if two detector heads are installed. The flowmeter's indication range is 1 - 10 SCFH. It has no flow adjustment valve because the flowrate is controlled by the regulator setting.

Calibration Valve

The calibration valve is a manual operation spring return valve with a push button actuator. This valve is used to switch from sample flow to calibration gas during the calibration process. When the button is pushed and held, the sample port is closed and the calibration port is opened.

Inlet/Blowback Valve

The inlet/blowback valve is a manual operation spring return valve. A push button actuator is located on the front of the valve. This valve is used to switch from sample flow to blow back in the event of a clogged sample line. When the push button is pressed and held, the valve diverts the compressed air supply back through the sample line to clear obstructions.

WARNING: *The blowback pressure can be as high as 140 PSI. Make sure that all personnel and equipment are clear of the sample line inlet end to avoid personal injury or equipment damage if a sample line obstruction is blown out of the sample line.*

Low Flow Switch/Low Flow Contact Housing

The low flow switch provides a normally open contact that closes in the event of a low flow condition. Two contact wires protrude from the side of the switch and enter the low flow contact housing through a plastic cable bushing on the left side of the housing. Terminals are provided in the housing for field connection to the switch contacts. A second plastic cable bushing on the bottom of the low flow contact housing allows for cable entry to the housing. The size range of the cable which can be routed through the second cable bushing is .064" - .210" OD.

Installation

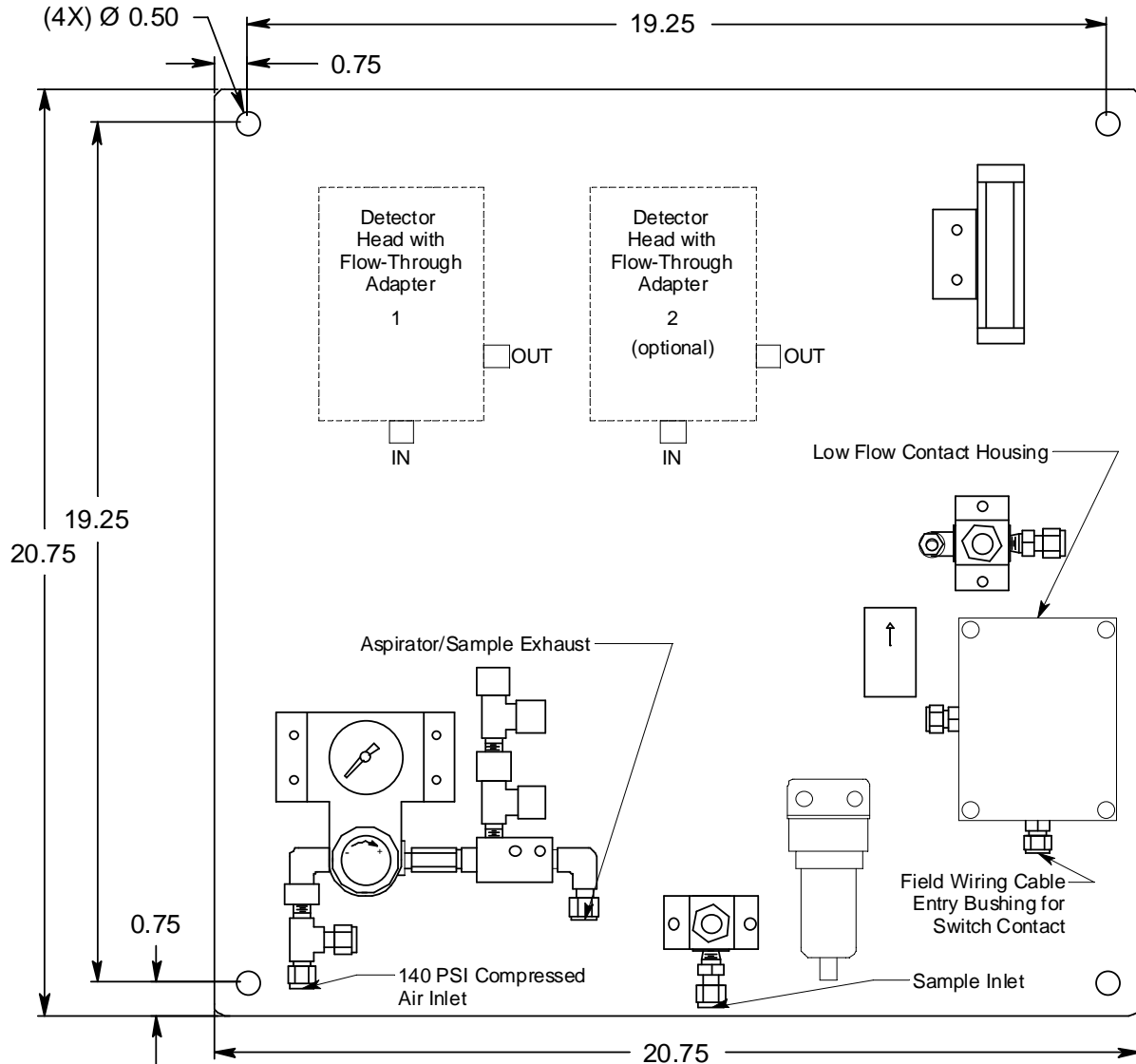

Figure 3: Outline & Mounting Dimensions

1. Install the mounting panel to a flat horizontal surface using the four mounting holes (0.50" diameter) in the corners of the panel. Make sure that sufficient space is allowed to remove the detector head's cover, and to bring power/signal wiring to the detector head. Also provide sufficient clearance for routing of sample, compressed air, and exhaust lines.
2. Connect power/signal wiring to the detector head(s) as described in the detector head operator's manual.
3. Start up the detector head(s) as described in the detector head operator's manual.
4. Connect a sample line from the area to be sampled to the sample inlet fitting at the bottom right of the panel. The fitting accepts 1/4" OD rigid metal tubing such as copper, aluminum, or stainless steel tubing. Be sure to use tubing appropriate for the target gas.
5. The aspirator exhaust includes the sample air. It may be routed to a different area where it can

be exhausted safely by running tubing from the aspirator exhaust fitting to the “safe” area. The aspirator exhaust fitting is a 1/4” OD tubing fitting.

6. Turn the regulator adjustment knob completely counterclockwise and then turn it one turn clockwise so that the flow will start out at a low level when the compressed air is connected and turned on.
7. Connect a compressed air source up to a maximum of 140 PSI to the inlet of the regulator. Although the regulator is rated up to 300 PSI inlet pressure, other components are rated to a maximum of 140 PSI.
8. Adjust the regulator adjustment knob so that the flowmeter indicates 3 SCFH. The regulator exhaust pressure indicated by the regulator gauge will vary for a particular flow depending on the length of the sample line and other restrictions such as filters. Typically the pressure will be between 5 and 10 PSI for short sample runs. It will be higher for longer sample runs and if filters are used.

NOTE: The 30-0954RK-250 includes a sample bypass which routes much of the sample flow around the detector(s). This maintains an optimal flowrate to the detector(s) of approximately 1 SCFH while minimizing the response time with a 3 SCFH sample flowrate.

9. Calibrate the detector head(s) as described below.

Calibration

1. Follow the instructions in the detector head operator’s manual for setting the zero (fresh air) reading and making span adjustments.
2. When introducing gas to the detector, fill a gas sample bag with a regulator or dispensing valve. See “Parts List” on page 8 for available parts.

NOTE: A gas bag is recommended for calibration instead of a demand flow regulator because a demand flow regulator introduces enough flow restriction to significantly reduce the flow. If a demand flow regulator is used, the flow will have to be adjusted up to 3 SCFH while the regulator is connected during calibration and down to 3 SCFH after calibration.

3. Connect the sample bag tubing to the hose barb calibration fitting on the calibration valve.
4. Push and hold the button on the calibration valve to start the flow of gas through the calibration gas fitting. Allow the sample draw adapter to draw sample for 2 minutes and then make any calibration adjustments necessary.
5. Release the push button on the calibration valve. Disconnect the sample bag from the calibration fitting.

Blowback Operation

1. In the event of a clogged sample line, the blowback valve can be used to divert the compressed air supply back through the sample line to clear obstructions.
2. Inspect the sample line first to try to remedy the situation without using the blowback valve. If the line cannot be cleared, operate the blowback valve as described below.
3. Make sure that all personnel and equipment are clear of the inlet end of the sample line.

- To operate the blowback valve, press and hold the button on the front of the blowback valve. As long as the button is held, compressed air will be applied to the sample line.

WARNING: *The blowback pressure can be as high as 140 PSI. Make sure that all personnel and equipment are clear of the sample line inlet end to avoid personal injury or equipment damage if a sample line obstruction is blown out of the sample line.*

- Release the button on the blowback valve. Verify that the sample is now flowing properly through the sample line.

Parts List

Table 2 lists replacement parts and accessories for the sample draw adapter.

Table 2: Parts List

Part Number	Description
06-1248RK-03	Tubing, 3/16 x 5/16, polyurethane, 3 foot length, for calibration kit
35-2000RK	Flow-through sample adapter
81-1001RK	Dispensing valve, for 34 liter steel cylinders
81-1051RK-60	Regulator with gauge and knob, 6 LPM, for 34 liter aluminum cylinder, 58 liter aluminum or steel, and 103 liter aluminum or steel cylinder
81-1127RK	Gas bag with fittings and hosebarb, 12 inches x 12 inches, 5 liters, tedlar