



INSTRUMENTS

65-2516RK
Oxygen Transmitter
Operator's Manual

Part Number: 71-0116RK

Revision: B

Released: 10/1/20

WARNING

Read and understand this instruction manual before operating detector. Improper use of the detector could result in bodily harm or death.

Periodic calibration and maintenance of the detector is essential for proper operation and correct readings. Please calibrate and maintain this detector regularly! Frequency of calibration depends upon the type of use you have and the sensor types. Typical calibration frequencies for most applications are between 3 and 6 months, but can be required more often or less often based on your usage.

Product Warranty

RKI Instruments, Inc. warrants gas alarm equipment sold by us to be free from defects in materials, workmanship, and performance for a period of one year from date of shipment from RKI Instruments, Inc. Any parts found defective within that period will be repaired or replaced, at our option, free of charge. This warranty does not apply to those items which by their nature are subject to deterioration or consumption in normal service, and which must be cleaned, repaired, or replaced on a routine basis. Examples of such items are:

- a) Absorbent cartridges
- b) Pump diaphragms and valves
- c) Fuses
- d) Batteries
- e) Filter elements

Warranty is voided by abuse including mechanical damage, alteration, rough handling, or repair procedures not in accordance with the operator's manual. This warranty indicates the full extent of our liability, and we are not responsible for removal or replacement costs, local repair costs, transportation costs, or contingent expenses incurred without our prior approval.

THIS WARRANTY IS EXPRESSLY IN LIEU OF ANY AND ALL OTHER WARRANTIES AND REPRESENTATIONS, EXPRESSED OR IMPLIED, AND ALL OTHER OBLIGATIONS OR LIABILITIES ON THE PART OF RKI INSTRUMENTS, INC. INCLUDING BUT NOT LIMITED TO, THE WARRANTY OF MERCHANTABILITY OR FITNESS FOR A PARTICULAR PURPOSE. IN NO EVENT SHALL RKI INSTRUMENTS, INC. BE LIABLE FOR INDIRECT, INCIDENTAL, OR CONSEQUENTIAL LOSS OR DAMAGE OF ANY KIND CONNECTED WITH THE USE OF ITS PRODUCTS OR FAILURE OF ITS PRODUCTS TO FUNCTION OR OPERATE PROPERLY.

This warranty covers instruments and parts sold to users by authorized distributors, dealers, and representatives as appointed by RKI Instruments, Inc.

We do not assume indemnification for any accident or damage caused by the operation of this gas monitor, and our warranty is limited to the replacement of parts or our complete goods.

Table of Contents

Overview	5
Specifications	5
Description	6
Oxygen Detector	6
Amplifier	7
Junction Box	8
Installation	8
Mounting the Oxygen Transmitter	8
Wiring the Oxygen Transmitter to a Controller	9
Startup	12
Introducing Incoming Power	12
Setting the Fresh Air Signal	12
Maintenance	13
Preventive Maintenance	13
Troubleshooting	14
Replacing Components of the Oxygen Transmitter	14
Calibration Frequency	17
Calibration	17
Preparing for Calibration	17
Setting the Fresh Air Reading	18
Setting the Zero Reading	18
Returning to Normal Operation	18
Parts List	19

Overview

This instruction manual describes the explosion proof capillary type oxygen transmitter. This manual also describes how to install, start up, configure, maintain, and calibrate the transmitter when using it with a gas monitoring controller. A parts list at the end of this manual lists replacement parts and accessories for the oxygen transmitter. See the controller operator's manual for information specific to the controller.

Specifications

WARNING: Do not use this product in a manner not specified in this instruction manual.

Table 1 lists specifications for the oxygen transmitter.

Table 1: Specifications

Target Gas	Oxygen (O ₂)
Area Classification	Explosionproof for Class I, Groups B, C, and D
Temperature Code	T6
Installation Category	Installation Category 1. Signal level, special equipment or parts of equipment, telecommunication, electronic, etc., with smaller transient overvoltages than Installation Category (Overvoltage Category) II (ref. IEC 664).
Input Voltage	11 VDC - 30 VDC
Sampling Method	Diffusion
Signal Output	4 to 20 mA
Detection Range	0 to 25% volume
Accuracy	± 0.5% O ₂
Oxygen Detector Signal Output	0 mV at 0% volume oxygen nominal 18 mV at 25% oxygen nominal
Response Time	90% in 30 seconds
Operating Temperature	-20°C to 45°C

NOTE: The following symbol on the detector label is a caution to the user to refer to this documentation for installation and operation instructions: 

WARNING: When using the 65-2516RK, you must follow the instructions and warnings in this manual to assure proper and safe operation of the 65-2516RK and to minimize the risk of personal injury. Be sure to maintain and periodically calibrate the 65-2516RK as described in this manual.

Description

This section describes the components of the oxygen transmitter. The transmitter consists of the oxygen detector, amplifier, and junction box.

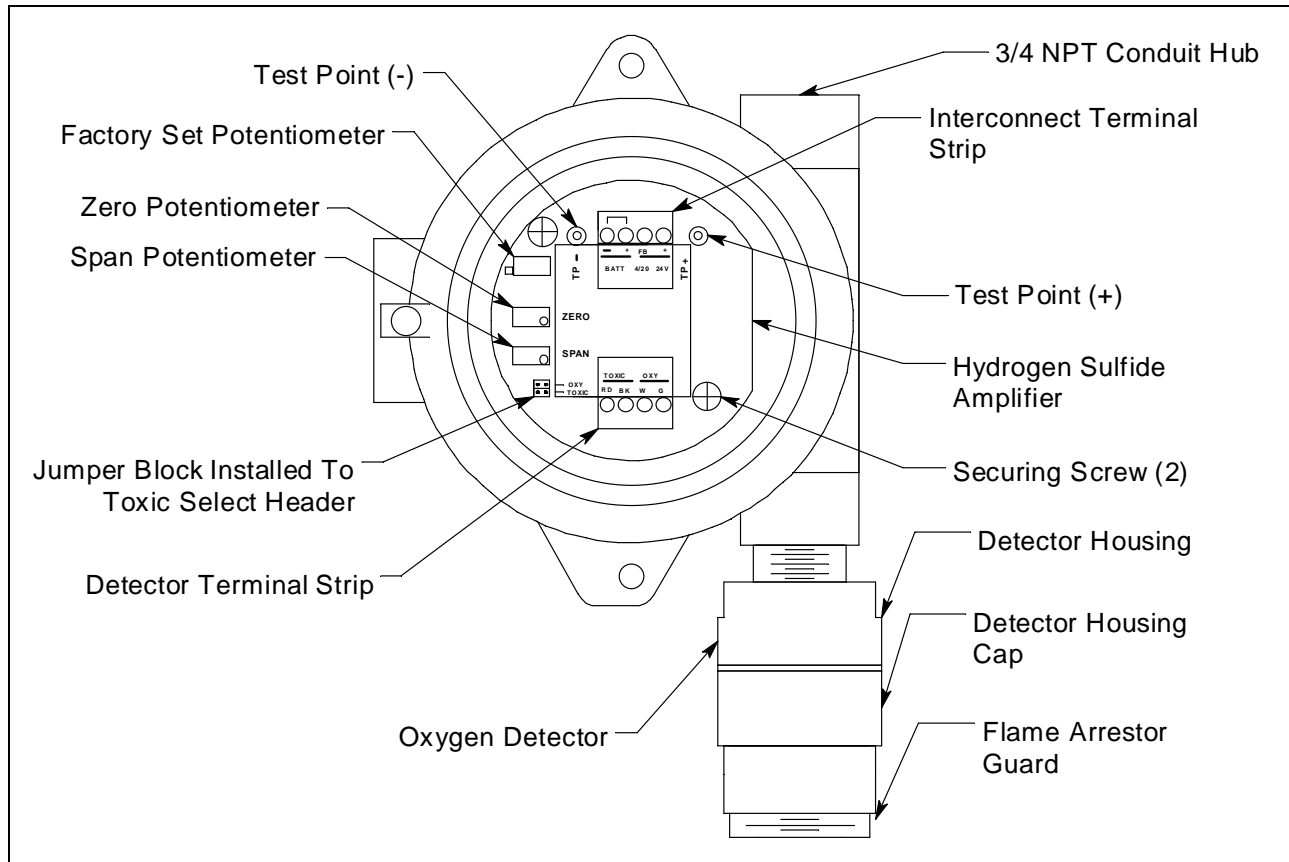

Figure 1: Oxygen Transmitter Component Location

Oxygen Detector

The oxygen detector includes the detector housing and sensor.

Detector Housing

The detector housing protects the sensing components within the housing. Use the mounting threads at the top of the housing to screw the oxygen detector into the bottom conduit hub of the junction box. Use the removable cap near the bottom of the housing to access the sensor for maintenance or replacement. The cap protects the sensor from damage and includes a flame arrester which contains any sparks which may occur within the detector housing. A cap gasket seals the interface between the housing and cap. The flame arrester guard is permanently bonded to the cap.

Two wires extend from the top of the detector housing. Use these wires to connect the oxygen detector to the amplifier. The housing includes sockets installed on a circuit board. These sockets accept the sensor's two pins to secure the sensor within the detector housing. The circuit board with the sockets conditions the sensor's signal before the signal reaches the amplifier.

Sensor

The sensor is secured within the sensor housing by the two pins. Through a series of chemical and electrical reactions, the sensor produces an electrical output that is proportional to the detector range of the transmitter.

Amplifier

The amplifier converts the electrical output from the sensor to a 4 to 20 mA signal (that is proportional to the detection range) and transmits the signal to a gas monitoring controller. The amplifier includes the amplifier type selector, detector terminal strip, interconnect terminal strip, span pot, zero pot, and test points (see Figure 1).

Amplifier Type Selector

The amplifier type selector is near the bottom left corner of the amplifier. It is to the left of the detector terminal strip and below the span pot.

The amplifier included with the oxygen transmitter is designed for use with RKI's oxygen and toxic gas transmitters. The amplifier type selector determines for which transmitter the amplifier is intended. For oxygen transmitters, a jumper block is installed over the **OXYGEN** selector (see Figure 1).

Detector Terminal Strip

The detector terminal strip is the four-point terminal strip near the bottom of the amplifier. Use the detector terminal strip to connect the oxygen detector to the amplifier.

NOTE: The oxygen detector is factory-wired to the amplifier. See the Installation section of this manual for all wiring procedures related to the transmitter.

Interconnect Terminal Strip

The interconnect terminal strip is the four-point terminal strip near the top of the amplifier. Use the interconnect terminal strip to connect the amplifier to a controller.

Span Pot

The span pot is on the left side of the amplifier. Of the three pots, the span pot is bottom most. Use the span pot to adjust the transmitter's fresh air output during the start-up and calibration procedures.

Zero Pot

The zero pot is above the span pot. Use the zero pot to adjust the transmitter's oxygen-free output during the calibration procedures.

CAUTION: *The third potentiometer is factory-set. Do not adjust it.*

Test Points

The test points (labeled **TP-** and **TP+**) are on the left and right side of the interconnect terminal strip. The test points produce a 100 to 500 mV output that is proportional to the transmitter's 4 to 20 mA output. Use the test points and a voltmeter to measure the

transmitter's output during the start-up and calibration procedures.

Junction Box

Use the junction box to install the oxygen transmitter at a mounting site that is remote from the controller. The junction box also protects the amplifier and wiring connections made to the amplifier. Use the two 3/4 NPT conduit hubs to mount the detector to the junction box (bottom hub) and connect wiring from the amplifier to the controller (top hub).

NOTE: The oxygen detector and amplifier are factory-mounted to the junction box.

Use the junction box's two mounting holes to mount the oxygen transmitter to a vertical surface at the monitoring site. Use the cover on the front of the junction box to access the interior of the junction box.

Installation

This section describes procedures to mount the oxygen transmitter in the monitoring environment and wire the transmitter to a gas monitoring controller.

Mounting the Oxygen Transmitter

1. Select a mounting site that is representative of the monitoring environment. Consider the following when you select the mounting site.
 - Select a site where the transmitter is not likely to be bumped or disturbed. Make sure there is sufficient room to perform start-up, maintenance, and calibration procedures.
 - Select a site that is at normal breathing level.

CAUTION: *Mount the oxygen transmitter with the detector facing down (see Figure 2).*

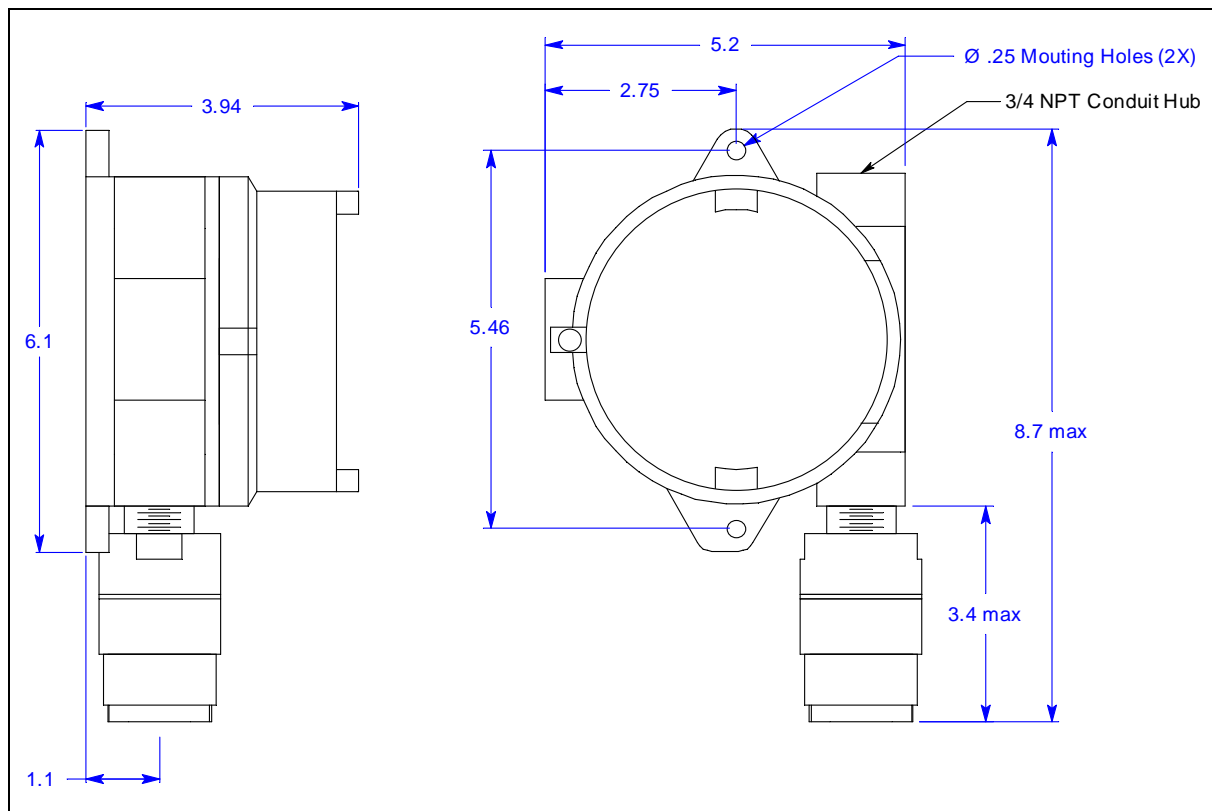

Figure 2: Mounting the Oxygen Transmitter

NOTE: The oxygen detector used in this transmitter is normally provided with a Killark HKB junction box and an HFC lid rated explosion proof for Class I, Groups B, C, and D. This combination is shown in Figure 2 above. Any junction box with an internal volume less than or equal to 69 cubic inches and rated explosion proof for Class I, Groups B, C, and D may be used for this transmitter as long as the amplifier will fit in it.

2. At the monitoring site, use #10 screws through the junction box's two mounting holes to secure the junction box to a vertical surface.

Wiring the Oxygen Transmitter to a Controller

WARNING: If the controller's construction is not explosion-proof, the controller must be installed in an ordinary location. Do not install a non-explosion-proof controller in a classified location. Turn off the controller.

1. Turn off the controller.
2. Turn off or unplug incoming power to the controller.
3. Remove the junction box cover.
4. Verify that the detector leads are wired to the amplifier's detector terminal strip. If necessary, connect the detector leads to the detector terminal strip as shown in Figure 3.

5. Verify that the jumper block is installed over the **Oxygen** selector of the amplifier type selector as shown in Figure 3.
6. Guide a two-conductor, shielded cable or two wires in conduit through the top conduit hub of the junction box.

WARNING: *To maintain the explosion proof classification of the oxygen detector/junction box combination, a conduit seal must be used within 18 inches of the detector junction box conduit hub used for wiring to the amplifier. Do not install the detector in an environment with acetic acid. Adhere to your local electrical code when installing the conduit seal.*

7. Connect the two wires to the interconnect terminal strip as follows (see Figure 3).
 - Connect the positive wire to the terminal labeled **24V +**.
 - Connect the feedback (or signal) wire to the terminal labeled **4/20 FB**.

CAUTION: *If using shielded cable, leave the drain wire insulated and disconnected at the transmitter. You will connect the opposite end of the cable's drain wire at the controller.*

8. Secure the junction box cover to the junction box.
9. Route the cable or wires leading from the oxygen transmitter through one of the conduit hubs at the controller housing.

CAUTION: *Do not route power and transmitter wiring through the same conduit hub. The power cable may disrupt the transmission of the transmitter signal to the controller.*

10. Connect the wires to the applicable controller transmitter terminal strip as shown in Figure 3.

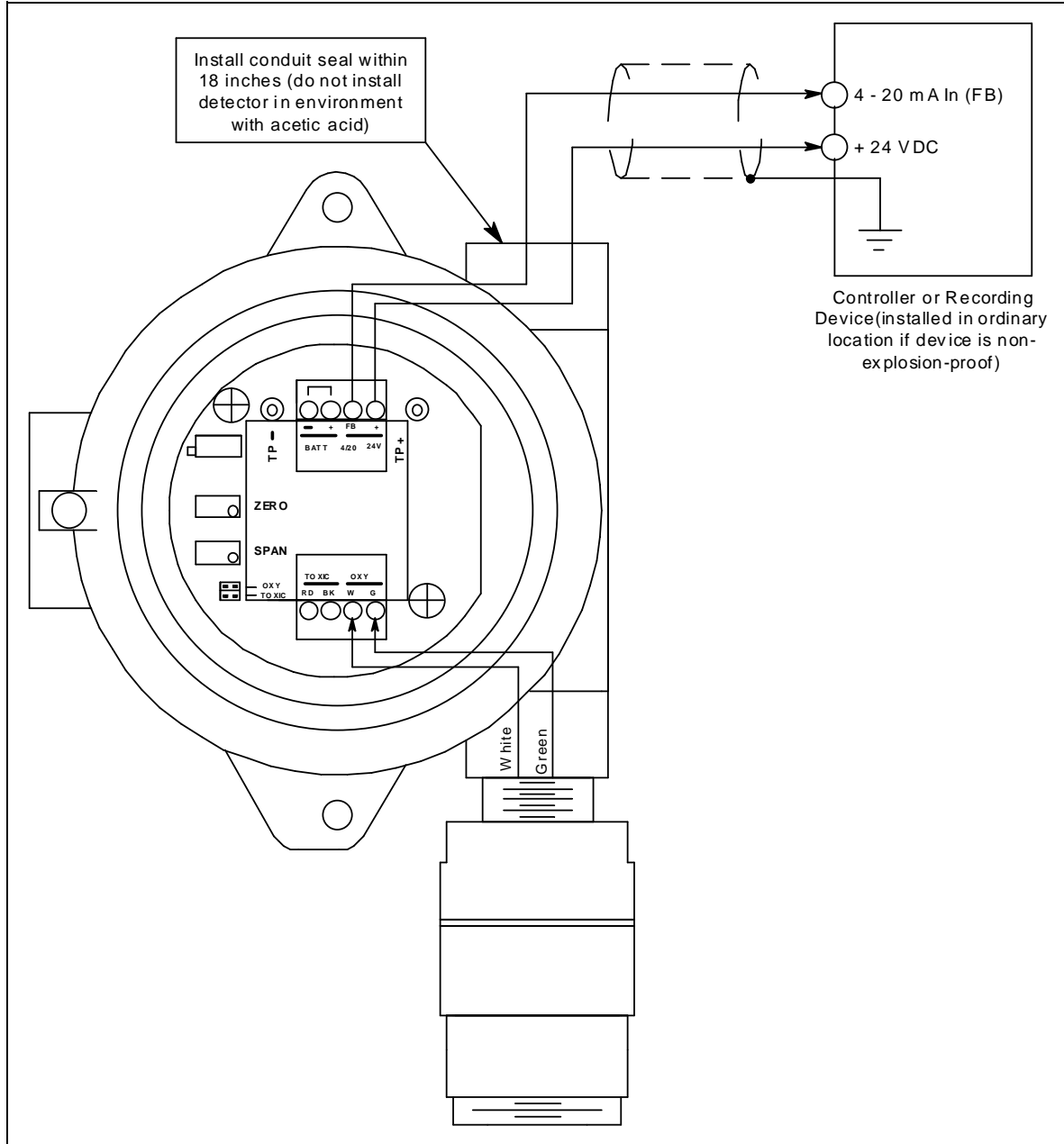

Figure 3: Wiring the Oxygen Transmitter to a Controller

11. If shielded cable is used, connect the cable's drain wire to an available chassis (earth) ground at the controller. RKI controllers typically have a ground stud that can be used to ground the cable's drain wire.

Start Up

This section describes procedures to start up the oxygen transmitter and place the transmitter into normal operation.

Introducing Incoming Power

1. Complete the installation procedures described earlier in this manual.
2. Verify that the power wiring to the controller is correct and secure. Refer to the controller operator's manual.
3. Turn on or plug in the incoming power to the controller, then turn on the controller.
4. Verify that the controller is on and operating properly. Refer to the controller operator's manual.

CAUTION: *Allow the transmitter to warm up for 5 minutes before you continue with the next section, "Setting the Fresh Air Signal".*

Setting the Fresh Air Signal

WARNING: *Do not remove the detector housing cap or junction box cover while the circuits are energized unless the area is determined to be non-hazardous. Keep the detector housing cap and junction box cover tightly closed during operation.*

NOTE: If you can verify that the detector is in a fresh air environment (environment known to be of normal oxygen content and free of toxic and combustible gases), it is not necessary to apply zero air when verifying or setting the fresh air reading.

The procedure below describes applying zero emission air, usually called zero air, using a calibration kit that includes a calibration cup, calibration gas, sample tubing, and a fixed flow regulator with an on/off knob. RKI Instruments, Inc. recommends using a 0.5 LPM (liters per minute) fixed flow regulator.

1. Verify that the transmitter area is non-hazardous.
2. Unscrew and remove the junction box cover from the junction box.
3. Set a voltmeter to measure in the millivolt (mV) range.
4. Plug the voltmeter leads into the test points on the amplifier. Plug the positive lead into the test point labeled **TP+**; plug the negative lead into the test point labeled **TP-**.
5. Screw the calibration cup onto the bottom of the detector.
6. Screw the regulator into the zero air calibration cylinder.
7. Use the sample tubing to connect the regulator to the calibration cup.
8. Turn the regulator's on/off knob counterclockwise to open it. Gas will begin to flow.

9. Allow the gas to flow for 2 minutes.
10. Verify a voltmeter reading of 434 mV (± 2 mV).
11. If necessary, use a flat-blade screwdriver to adjust the span pot until the voltmeter reading is 434 mV (± 2 mV).
12. Turn the regulator's on/off knob clockwise to close it.
13. Unscrew the calibration cup from the detector.
14. Unscrew the regulator from the zero air calibration cylinder. For convenience, leave the sample tubing connected to the regulator and the calibration cup.
15. Store the components of the calibration kit in a safe and convenient place.
16. Remove the voltmeter leads from the test points.
17. Secure the junction box cover to the junction box.

Maintenance

This section describes maintenance procedures. It includes preventive maintenance, troubleshooting, and component replacement procedures.

Preventive Maintenance

This section describes a preventive maintenance schedule to ensure the optimum performance of the oxygen transmitter. It includes daily and quarterly procedures.

Daily

Verify a display reading of 20.9% oxygen at the controller. Investigate significant changes in the reading.

Quarterly

Calibrate the detector as described in "Calibration" on page 17. See the calibration frequency discussion in the calibration section to determine if a quarterly calibration schedule fits your needs.

Troubleshooting

The troubleshooting guide describes symptoms, probable causes, and recommended action for problems you may encounter with the oxygen transmitter.

NOTE: This troubleshooting guide describes transmitter problems only. See the controller operator's manual for problems you may encounter with the controller.

Table 2: Troubleshooting the Oxygen Transmitter

Condition	Symptom(s)	Probable Causes	Recommended Action
Fail Condition	<ul style="list-style-type: none"> Controller indicates a fail condition. 	<ul style="list-style-type: none"> The transmitter wiring is disconnected or misconnected. The transmitter is malfunctioning. 	<ol style="list-style-type: none"> Verify that the transmitter wiring is correct and secure. Calibrate the transmitter. If the fail condition continues, replace the oxygen sensor. If the fail condition continues, contact RKI for further instruction.
Slow or No Response/ Difficult or Unable to Calibrate	<ul style="list-style-type: none"> Unable to accurately set the fresh air or zero reading during calibration. Transmitter requires frequent calibration. <p><i>Note: Under "normal" circumstances, the transmitter requires calibration once every three months. Some applications may require a more frequent calibration schedule.</i></p>	<ul style="list-style-type: none"> The calibration cylinder is low, out-dated, or defective. The flame arrestor in the detector housing cap is wet or clogged with dirt or other particulates. The transmitter is malfunctioning. 	<ol style="list-style-type: none"> Verify that the calibration cylinder contains an adequate supply of a fresh test sample. Check the detector housing cap to determine if the flame arrestor is wet or dirty. Clean or replace if necessary. If the calibration/response difficulties continue, replace the oxygen sensor. If the calibration/response difficulties continue, contact RKI for further instructions.

Replacing Components of the Oxygen Transmitter

This section includes procedures to replace the oxygen sensor and amplifier. A procedure to replace the entire detector assembly is at the end of this section. In most cases, it is not necessary to replace the entire detector assembly.

Replacing the Oxygen Sensor

- Turn off the controller.
- Turn off or unplug incoming power to the controller.
- Unscrew the detector housing cap from the detector housing.
- Unplug and remove the oxygen sensor.
- Carefully plug the replacement sensor into the socket pattern that is located in the top section of the detector housing.

NOTE: Match the sensor's male pins with the two female sockets as you plug the sensor into the socket.

6. Screw the detector housing cap onto the detector housing.
7. Turn on or plug in incoming power to the controller.
8. Turn on the controller.

CAUTION: Allow the replacement sensor to warm up for 5 minutes before you continue with the next step.

9. Calibrate the replacement sensor as described in the Calibration section of this manual.

Replacing the Amplifier

1. Turn off the controller.
2. Turn off or unplug incoming power to the controller.
3. Remove the junction box cover.
4. Disconnect the detector leads from the detector terminal strip.
5. Unscrew and remove the two screws that secure the amplifier to the junction box. The screws are at the top left and bottom right of the amplifier.
6. Remove the amplifier.
7. Place the new amplifier in the same position as the old amplifier.
8. Use the two screws you removed in step 5 to secure the new amplifier to the junction box.
9. Verify that the jumper block is installed over the **OXYGEN** selector of the amplifier type selector as shown in Figure 3.
10. Reconnect the wiring from the controller to the interconnect terminal strip as shown in Table 3 and Figure 3.

Table 3: Reconnecting the Oxygen Amplifier to a Controller

Amplifier Interconnect Terminal Strip	Controller Transmitter Terminal Strip (typical)
4/20 FB	4 -20 (FB)
24V +	+ V (11 - 30 VDC)

11. Reconnect the detector leads to the detector terminal strip as shown in Table 4 and Figure 3.

Table 4: Reconnecting the Oxygen Detector to the Amplifier

Oxygen Detector Lead	Amplifier Interconnect Terminal Strip
White	OXY W
Green	OXY G

12. Reinstall the junction box cover.
13. Turn on or plug in incoming power to the controller.
14. Turn on the controller.

CAUTION: Allow the transmitter to warm up for 5 minutes before you continue with the next step.

15. Calibrate the oxygen transmitter as described in the Calibration section of this manual.

Replacing the Oxygen Detector

NOTE: In most cases, it is only necessary to replace the oxygen sensor.

1. Turn off the controller.
2. Turn off or unplug incoming power to the controller.
3. Remove the junction box cover.
4. Disconnect the detector leads from the detector terminal strip. Note the position of the color-coded leads as you remove them.
5. Unscrew the detector from the junction box.
6. Guide the detector leads of the replacement detector through the bottom conduit hub of the junction box, then screw the mounting threads of the detector into the conduit hub.
7. Connect the detector leads to the detector terminal strip as shown in Table 4 and Figure 3.

Table 5: Connecting the Replacement Oxygen Detector to the Amplifier

Oxygen Detector Lead	Amplifier Interconnect Terminal Strip
White	OXY W
Green	OXY G

8. Reinstall the junction box cover.

9. Turn on or plug in incoming power to the controller.
10. Turn on the controller.

CAUTION: *Allow the replacement detector to warm up for 5 minutes before you continue with the next step.*

11. Calibrate the replacement detector as described in “Calibration” on page 17.
12. Secure the junction box cover to the junction box.

Calibration Frequency

Although there is no particular calibration frequency that is correct for all applications, a calibration frequency of every 3 to 6 months is adequate for most applications. Unless experience in a particular application dictates otherwise, RKI Instruments, Inc. recommends a calibration frequency of every 3 months (quarterly).

If an application is not very demanding, for example detection in a clean, temperature controlled environment, and calibration adjustments are minimal at calibration, then a calibration frequency of every 6 months is adequate.

If an application is very demanding, for example if the environment is not well controlled, then more frequent calibration than every 3 months may be necessary.

Calibration

This section describes how to calibrate the oxygen transmitter. It includes procedures to prepare for calibration, set the fresh air reading, set the zero reading, and return to normal operation. It describes the test using a calibration kit that includes a calibration cup, calibration gas, sample tubing, and a fixed flow regulator with an on/off knob. RKI Instruments, Inc. recommends using a 0.5 LPM (liters per minute) fixed flow regulator.

Preparing for Calibration

NOTE: Calibrating the oxygen transmitter may cause alarms. Be sure to put the controller into its calibration program or disable external alarms before continuing.

1. Unscrew and remove the junction box cover.
2. Set a voltmeter to measure in the millivolt (mV) range.

WARNING: *Do not remove the detector housing cap or junction box cover while the circuits are energized unless the area is determined to be non-hazardous. Keep the detector housing cap and junction box cover tightly closed during operation.*

3. Plug the positive lead into the test point labeled **TP+**; plug the negative lead into the test point labeled **TP-**.

4. Screw the calibration cup onto the detector housing.

Setting the Fresh Air Reading

NOTE: If you can verify that the oxygen transmitter is in a fresh air environment, you do not need to apply zero air to the detector before adjusting the zero reading.

1. Screw the regulator into the zero air calibration cylinder.
2. Use the sample tubing to connect the regulator to the calibration cup.
3. Turn the regulator's on/off knob counterclockwise to open it.
4. Allow the gas to flow for 2 minutes.
5. Verify a voltmeter reading of 434 mV (± 2 mV).
6. If necessary, use a flat-blade screwdriver to adjust the span pot on the amplifier until the voltmeter reading is 434 mV (± 2 mV).
7. Turn the regulator on/off knob clockwise to close it.
8. Unscrew the regulator from the zero air calibration cylinder.

Leave the sample tubing connected to the regulator and the calibration cup.

Setting the Zero Reading

1. Screw the regulator into the 100% nitrogen calibration cylinder.
2. Turn the regulator's on/off knob counterclockwise to open it.
3. Allow the gas to flow for two minutes and verify a reading of 100 mV (± 2 mV).
4. If necessary, use the zero pot on the amplifier to adjust the reading to 100 mV (± 2 mV).
5. Turn the regulator's on/off knob clockwise to close it.
6. Unscrew the regulator from the calibration cylinder.
7. Unscrew the calibration cup from the oxygen detector.

NOTE: For convenience, leave the components of the calibration kit connected by the sample tubing.

Returning to Normal Operation

1. Remove the voltmeter leads from the amplifier test points.
2. Secure the junction box cover to the junction box.
3. When the display reading rises above the decreasing alarm setpoint, return the controller to normal operation.

NOTE: If you do not allow the oxygen reading to increase above the decreasing alarm point, then unwanted alarms may occur.

4. Verify that the display reading increases and stabilizes at 20.9% volume.
5. Store the components of the calibration kit in a safe and convenient place.

Parts List

Table 5 lists replacement parts and accessories for the oxygen transmitter.

Table 6: Parts List

Part Number	Description
06-1248RK	Sample tubing (order by the foot)
07-0033RK	Detector housing cap gasket
18-0405RK-01	Junction box (without cover; pre drilled for amplifier)
18-0406RK	Junction box cover
57-1062RK	Amplifier for oxygen transmitter
65-1025RK	Oxygen replacement sensor, plug-in
65-2514RK	Oxygen replacement detector assembly (includes sensor), CSA classified
65-2516RK	Oxygen transmitter (includes detector and amplifier), CSA classified
71-0116RK	<i>Oxygen Transmitter Operator's Manual</i> (this document)
81-F301RK-LV	Calibration kit, 34 liter
81-0076RK-01	Zero air calibration cylinder, 34 liter steel
81-0078RK	Calibration cylinder, 100% nitrogen, 17 liter
81-0078RK-01	Calibration cylinder, 100% nitrogen, 34 liter steel
81-1050RK	Regulator with gauge and knob, 0.5 LPM, for 17 liter and 34 liter steel calibration cylinders (cylinders with external threads)
81-1117RK	Calibration cup