

M2 Transmitter for 12 VDC Operation Operator's Manual

Part Number: 71-0115RK

Revision: I

Released: 10/14/15

WARNING

Read and understand this instruction manual before operating transmitter. Improper use of the transmitter could result in bodily harm or death.

Periodic calibration and maintenance of the transmitter is essential for proper operation and correct readings. Please calibrate and maintain this transmitter regularly! Frequency of calibration depends upon the type of use you have and the sensor types. Typical calibration frequencies for most applications are between 3 and 6 months, but can be required more often or less often based on your usage.

Product Warranty

RKI Instruments, Inc. warrants gas alarm equipment sold by us to be free from defects in materials, workmanship, and performance for a period of one year from date of shipment from RKI Instruments, Inc. Any parts found defective within that period will be repaired or replaced, at our option, free of charge. This warranty does not apply to those items which by their nature are subject to deterioration or consumption in normal service, and which must be cleaned, repaired, or replaced on a routine basis. Examples of such items are:

- a) Absorbent cartridges
- b) Pump diaphragms and valves
- c) Fuses
- d) Batteries
- e) Filter elements

Warranty is voided by abuse including mechanical damage, alteration, rough handling, or repair procedures not in accordance with the operator's manual. This warranty indicates the full extent of our liability, and we are not responsible for removal or replacement costs, local repair costs, transportation costs, or contingent expenses incurred without our prior approval.

THIS WARRANTY IS EXPRESSLY IN LIEU OF ANY AND ALL OTHER WARRANTIES AND REPRESENTATIONS, EXPRESSED OR IMPLIED, AND ALL OTHER OBLIGATIONS OR LIABILITIES ON THE PART OF RKI INSTRUMENTS, INC. INCLUDING BUT NOT LIMITED TO, THE WARRANTY OF MERCHANTABILITY OR FITNESS FOR A PARTICULAR PURPOSE. IN NO EVENT SHALL RKI INSTRUMENTS, INC. BE LIABLE FOR INDIRECT, INCIDENTAL, OR CONSEQUENTIAL LOSS OR DAMAGE OF ANY KIND CONNECTED WITH THE USE OF ITS PRODUCTS OR FAILURE OF ITS PRODUCTS TO FUNCTION OR OPERATE PROPERLY.

This warranty covers instruments and parts sold to users by authorized distributors, dealers, and representatives as appointed by RKI Instruments, Inc.

We do not assume indemnification for any accident or damage caused by the operation of this gas monitor, and our warranty is limited to the replacement of parts or our complete goods.

Table of Contents

Chapter 1: Introduction	1
Overview	1
About the M2 Transmitter	1
About this Manual.....	1
Specifications	2
Chapter 2: Description	3
Overview	3
External Description	3
Internal Description	4
Chapter 3: Installation & Startup	8
Overview	8
Mounting the M2 Transmitter	8
Wiring the M2 Transmitter	9
Start Up	11
Chapter 4: Operation	13
Overview	13
Normal Operation	13
Information Screen.....	13
4 - 20 mA Signal Output Operation	13
Alarm Indications	14
Chapter 5: Configuration Mode	17
Overview	17
Viewing & Changing M2 Parameters	17
Chapter 6: Gas Type Mode	20
Overview	20
Selecting the Gas Type	20

Chapter 7: Maintenance	22
Overview.....	22
Preventive Maintenance	22
Troubleshooting.....	23
Calibration Frequency.....	25
Calibration.....	25
Replacing Components of the M2	28
Chapter 8: RS-485 Modbus Output	29
Overview.....	29
Wiring the M2 in a Modbus System	29
Using the M2 in a 4-wire Modbus System	31
Modbus Mode	31
Supported Modbus Functions	33
Parts List	38
Appendix A: Control Button Quick Reference Guide	39
Appendix B: PLC and DCS Device Wiring	40
Appendix C: Function Code 16 Registers	42
(Appendix C available from RKI Instruments, Inc. Not in manual as normally provided with M2 detector head.)	

Chapter 1: Introduction

Overview

This chapter briefly describes the M2 Transmitter. This chapter also describes the *M2 Transmitter Operator's Manual* (this document). Table 1 at the end of this chapter lists the specifications for the M2.

About the M2 Transmitter

The M2 Transmitter is a fixed mount, continuous-monitoring detector head. All user adjustable parameters may be accessed using push button switches. In addition, calibration may be performed non-intrusively by use of a magnetic wand accessory which activates magnetic switches through a window at the front face of the detector head.

The M2 displays the current gas reading on an LCD display which is visible through the window in the cover (front face) and provides a 4 - 20 mA signal which indicates the target gas reading for use by a gas monitoring controller, recording device, or programmable controller. The M2 also provides an RS-485 Modbus output. Three sets of relay contacts, two controlled by the gas alarms and one by the fail alarm, rated at 115 VAC 5 amps are available for controlling devices such as lights or horns or for controlling higher rated relays.

Four operating modes allow you to display and change setup and calibration settings and change the gas type. They are Calibration Mode, Configuration Mode, Gas Type Mode, and Modbus Mode.

NOTE: Only the LEL version of the M2 is available for 12 VDC operation.

About this Manual

The *M2 Transmitter Operator's Manual* uses the following conventions for notes, cautions, and warnings.

NOTE: Describes additional or critical information.

CAUTION: Describes potential damage to equipment.

WARNING: Describes potential danger that can result in injury or death.

Specifications

Table 1 lists specifications for the M2.

Table 1: M2 Specifications

Target Gas/Detection Range	Combustible (LEL) Gas: 0 - 100% LEL, 1% LEL increments
Alarm Settings*	<ul style="list-style-type: none">• Alarm 1: 10 %LEL• Alarm 2: 50 %LEL
Construction (housing)	Explosion-proof Junction Box, NEMA 4
Area Classification	Explosion-proof for Class I, Groups B, C, and D (LEL and toxic versions)
Sampling Method	Diffusion
Input Power	10.8 - 14.5 VDC
Controls	<ul style="list-style-type: none">• Three push button switches• Three magnetic switches for non-intrusive calibration
Weight	4.5 lbs.
Signal Output	<ul style="list-style-type: none">• 4 to 20 mA, 350 ohms impedance max• RS-485 Modbus
Operating Temperature	-20°C to 50°C
Accuracy	± 5% of reading or ± 2% LEL (whichever is greater)
* These are the RKI factory settings. You can change the alarm settings in Configuration Mode. See “Viewing & Changing M2 Parameters” on page 17.	

WARNING: *When using the M2, you must follow the instructions and warnings in this manual to assure proper and safe operation of the M2 and to minimize the risk of personal injury. Be sure to maintain and periodically calibrate the M2 as described in this manual.*

WARNING: *M2 detector heads with firmware version 5.0 or later have a different Modbus register assignment than M2s with previous versions of firmware. If you are adding M2s with firmware version 5.0 or later to an existing Modbus network installation, confirm what firmware version is installed in the M2s already in the network and if necessary, take all steps required to address the differences in Modbus register assignments. See “Supported Modbus Functions” on page 33 for information on the current Modbus register assignments. The firmware version is shown on the Information Screen described on page 13.*

Chapter 2: Description

Overview

This chapter describes external and internal components of the M2 Transmitter.

External Description

This section describes the junction box and all external components of the M2 transmitter.

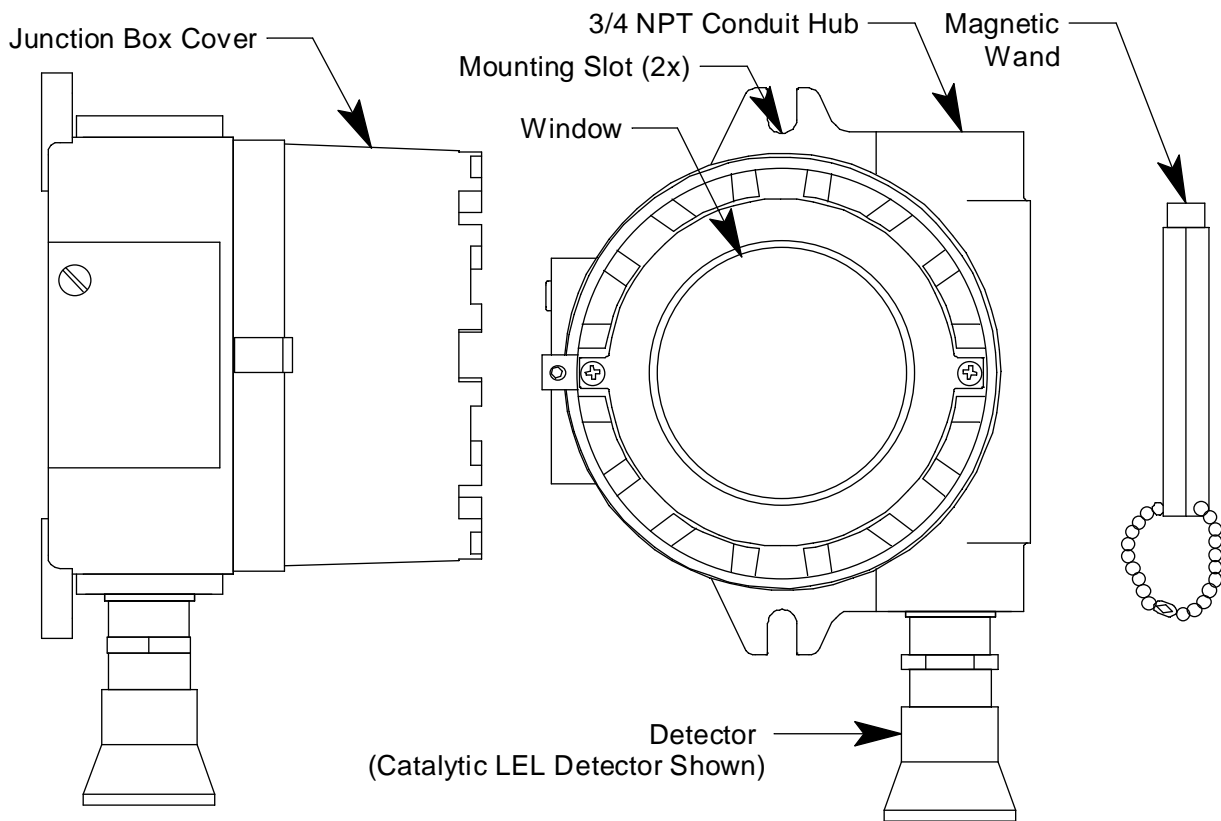

Figure 1: M2 External Components

Junction Box

The M2's cast aluminum junction box is dust and weather resistant. The junction box also protects the M2 and all connections made to it. Use the two 3/4 in. conduit hubs to mount the detector to the junction box (factory installed in the bottom hub) and connect wiring from an external device (top hub).

Use the junction box's two mounting holes to mount the M2 to a vertical surface at the monitoring site. The window in the cover on the front of the junction box allows you to view the LCD display and use the magnetic wand to actuate the magnetic control switches so you can perform non-intrusive calibration. Removing the cover allows you to access the interior of the junction box.

Magnetic Wand

The magnetic wand is a short plastic rod with a magnet in one end. It is used to actuate the magnetic control switches on the control PCB while the junction box cover is still installed so that non-intrusive calibration can be performed.

LEL Detector

The LEL detector senses the target gas and is mounted in a 3/4" conduit hub on the right bottom side of the M2. The LEL detector has a 1/2" NPT thread and requires a 3/4" NPT x 1/2" NPT reducer to mount it in the detector hub.

Internal Description

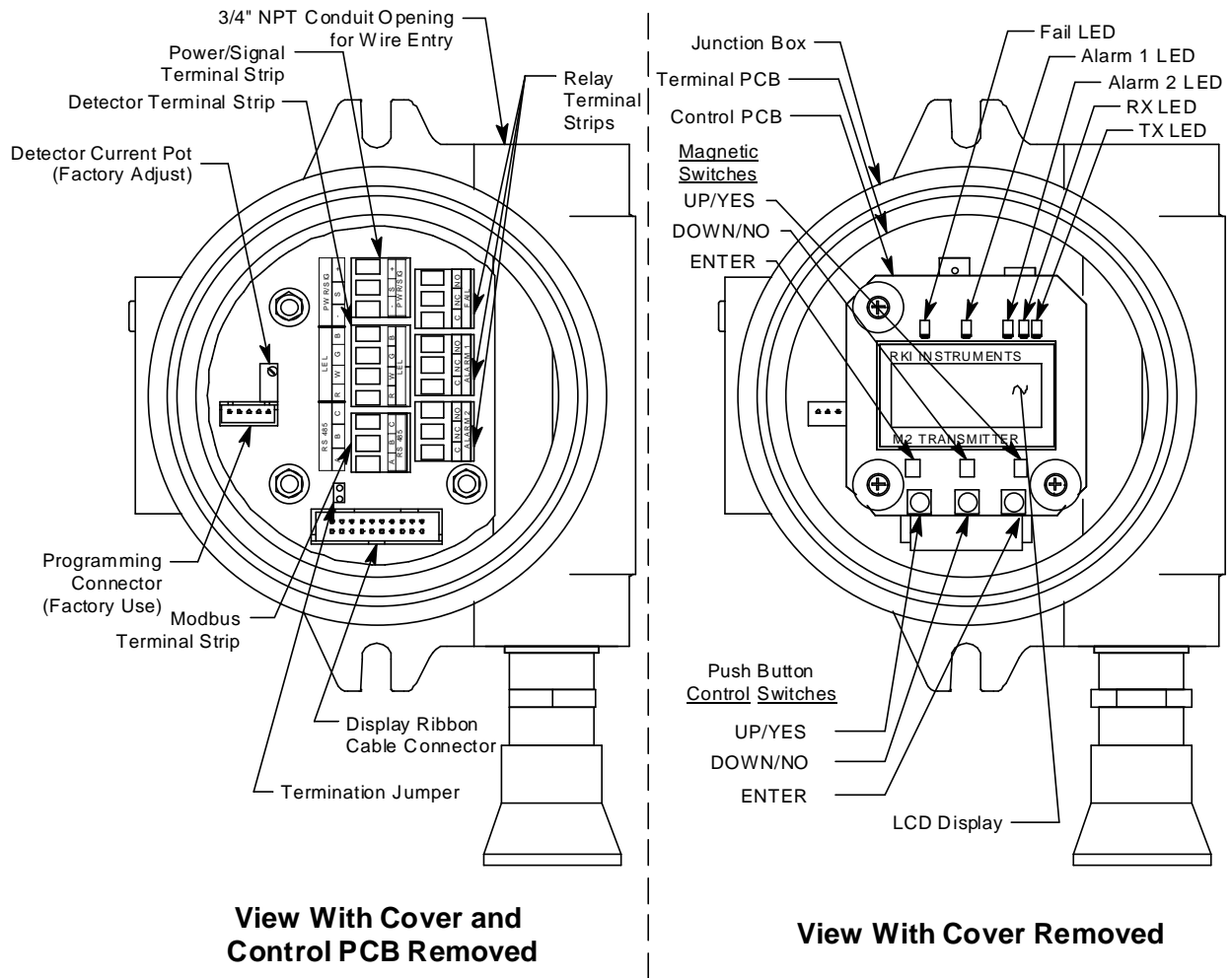

Figure 2: M2 Internal Components

Terminal PCB

The terminal PCB is encapsulated in epoxy for protection against moisture and physical damage. It is mounted into the rear of the junction box with three standoffs and rests on a thin layer of foam. A banana jack is screwed into each of the standoffs and used for mounting the control PCB. The terminal PCB converts the electrical output from the detector to a signal which can be displayed by the LCD display, a 4 - 20 mA signal (that is proportional to the detection range) and an RS-485 Modbus output signal. The 4 - 20 mA signal may be used by a recording device, gas monitor controller, or programmable controller. The Modbus output may be used to connect the M2 to a Modbus network. The terminal PCB also controls three relays, one fail and two gas alarm relays.

Two columns of plug-in style terminal strips are used to make all wiring connections to the M2. The column on the left consists of the power/signal, detector, and Modbus terminal strips. The column on the right consists of the relay terminal strips. A 20 position connector at the bottom of the terminal PCB is used to connect the terminal PCB to the control PCB with a ribbon cable. A 5 position connector on the left side of the terminal PCB is used by factory or field service personnel to program the M2. A factory adjust pot just above the programming connector is used to set the LEL detector current.

Power/Signal Terminal Strip

The power/signal terminal strip is a three position plug-in style terminal strip located at the top of the left terminal column. It is used to connect 12 VDC power to the M2 and to connect the 4 - 20 mA output signal to a device.

The signal output, the S terminal, does not have to be connected for the M2 to function. The S terminal is used if you want to connect the 4 - 20 mA output signal to another device such as a gas monitoring controller, chart recorder, or programmable controller (PLC).

Detector Terminal Strip

The detector terminal strip is a four position plug-in style terminal strip and is the middle terminal strip in the left terminal column. It is used to connect the LEL detector to the M2.

NOTE: The LEL detector is factory-wired to the M2. See "Wiring the M2 Transmitter" on page 9 for all wiring procedures related to M2.

Modbus Terminal Strip

The Modbus terminal strip is a three position plug-in style terminal strip and is the bottom terminal strip in the left terminal column. It allows connection of the M2 into a Modbus network.

Relay Terminal Strips

The right column of terminal strips consists of, from top to bottom, the fail, alarm 1, and alarm 2 relay terminal strips. They are three-position plug-in style terminal strips. The relay terminal strips are used to connect devices such as lights and horns that are controlled by the relay contacts. The relay contacts are rated at 115 VAC, 5 amps. The relay contacts may also be used to control higher rated relays.

Termination Jumper

A two pin header with a termination jumper installed is located below the Modbus terminal strip. The jumper has no function unless the M2 is wired into a Modbus installation. See "Chapter 8: RS-485 Modbus Output" on page 29 for a description of using the M2 in a Modbus system.

Control PCB

The LCD display and control switches are located on the control PCB. It is installed on top of the terminal PCB by lining up its three spacing standoffs with the banana jacks in the terminal PCB mounting standoffs and pushing it onto the banana jacks. The jacks retain the control PCB.

LCD Display

The LCD display is located at the top of the control PCB. It indicates the current gas reading and displays messages and parameters in the M2's programs.

Control Buttons

The M2 includes three push button switches that allow you to enter the M2's operating modes, navigate through the modes, update settings, and save changes to the settings. The push button switches are located along the bottom edge of the control PCB (see Figure 2). The UP/YES button is on the left, the DOWN/NO button is in the middle, and the ENTER button is on the right.

Table 2: M2 Control Button Functions

Switch	Function
UP (YES)	<ul style="list-style-type: none">• Saves settings• Changes the displayed setting• Enters the Calibration Program• Enters Gas Type Mode (press with DOWN/NO button)• Enters Configuration Mode (press with ENTER button)
DOWN (NO)	<ul style="list-style-type: none">• Cancels setting changes• Changes the displayed setting• Enters Gas Type Mode (press with UP/YES button)• Enters Modbus Mode (press with ENTER button)• Displays the Information Screen
ENTER	<ul style="list-style-type: none">• Initiates operations• Enters Configuration Mode (press with UP/YES button)• Enters Modbus Mode (press with DOWN/NO button)• Functions as an alarm reset switch

Just above each push button switch is a magnetic switch with the same function as the push button switch below it. The magnetic switches are for use in non-intrusive calibration. They are actuated by bringing the magnetic wand close enough to them to actuate them. Although the magnetic switches have the same functions as the push button switches, it is not practical to use them for operations other than calibration because it is not possible to actuate two magnetic switches at once with only one magnetic wand. Since displaying the Information Screen only requires the use of one switch, the wand may be used to show the Information Screen.

Status LEDs

The M2 includes five status LEDs that are located above the display (see Figure 2).

- **Fail LED**

The fail LED turns on when the M2 is experiencing a fail condition. A fail condition can be caused by a detector failure or low detector signal.

- **Alarm 1 LED**

The alarm 1 LED is on when the M2 is experiencing an alarm 1 condition.

- **Alarm 2 LED**

The alarm 2 LED is on when the M2 is experiencing an alarm 2 condition.

- **RX & TX LED's**

These LED's indicate data being received (RX) and transmitted (TX) when the M2's Modbus output is operating.

Chapter 3: Installation & Startup

Overview

This chapter describes procedures to mount the M2 Transmitter in the monitoring environment and wire it to input power and devices.

Mounting the M2 Transmitter

1. Select a mounting site that is representative of the monitoring environment. Consider the following when you select the mounting site.
 - Select a site where the M2 is not likely to be bumped or disturbed. Make sure there is sufficient room to perform start-up, maintenance, and calibration procedures.
 - Select a site where the target gas is likely to be found first. For lighter gases, mount the detector near the ceiling; for heavier gases, mount the detector near the floor.
2. At the monitoring site, use #10 screws through the junction box's two mounting holes to secure the junction box to a vertical surface. Figure 3 shows the outline and mounting dimensions of the M2. Mount the M2 with the detector facing down as shown in Figure 3.

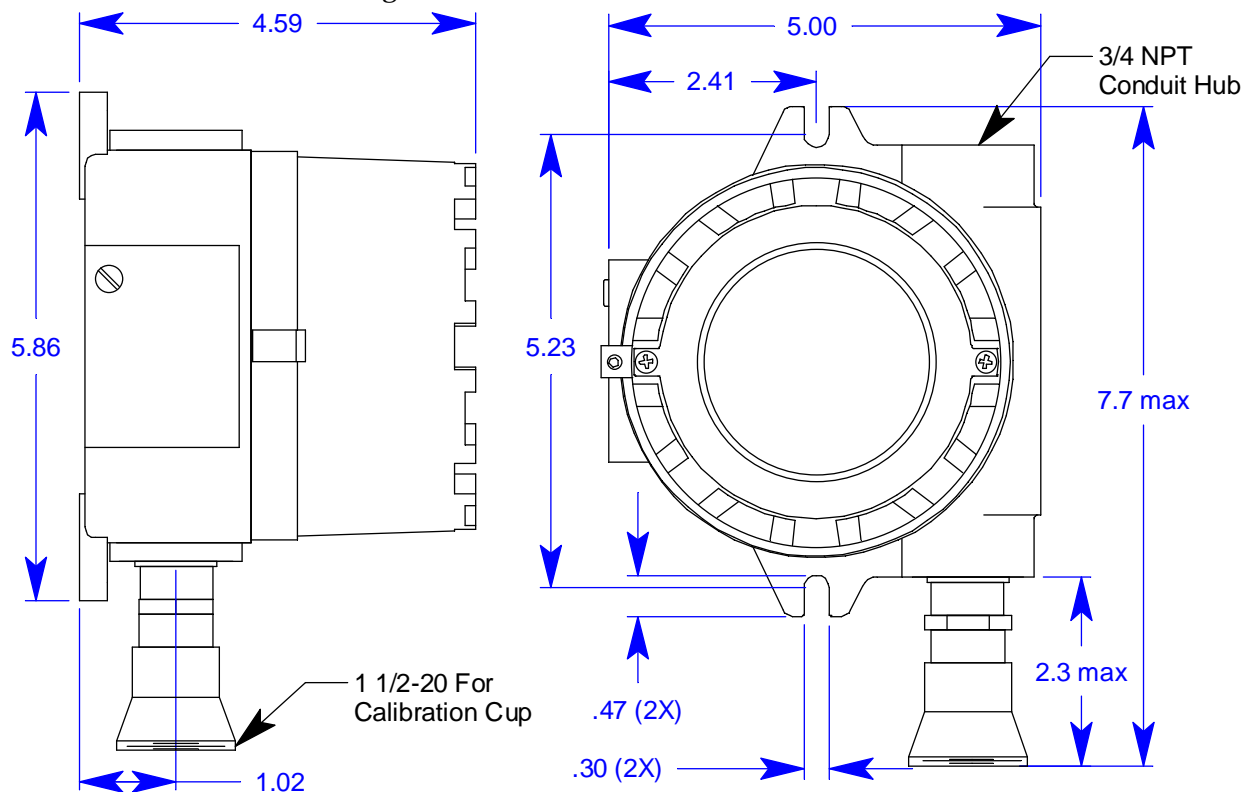

Figure 3: Outline & Mounting Dimensions, LEL

Wiring the M2 Transmitter

WARNING: Always verify that the power source is OFF before making any wiring connections.

1. Remove the junction box cover.
2. Grasp the control PCB by its edges.
3. Gently pull until the control PCB is pulled away from the banana jacks. Take care not to pull too hard and damage the cable which connects the control and terminal PCB's.
4. Let the control PCB hang by the cable. The terminal strips are now visible on the terminal PCB. The control PCB may be left hanging while wiring is done. If desired, the control PCB may be disconnected from the cable and set aside while wiring.
5. The detector leads are factory wired. Verify that the detector leads are wired to the detector terminal strip as shown below: Red wire to terminal labeled LEL R, white wire to terminal labeled LEL W, green wire to terminal labeled LEL G, black wire to terminal labeled LEL B.

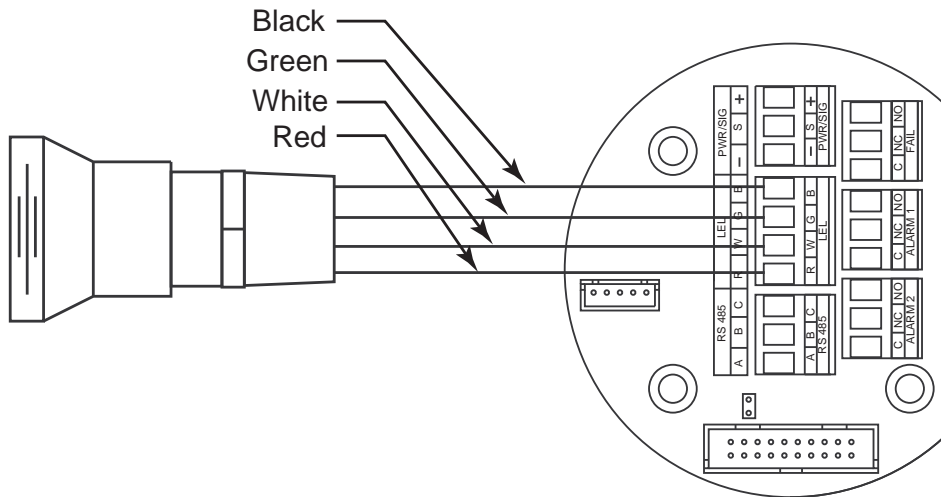

Figure 4: LEL Detector Wiring

6. To gain access to a plug-in terminal strip for wiring, pull it out of its socket by grasping the wall between two terminal positions with needle nose pliers and pulling. Be careful not to exert too much force on the wall to avoid damage to the terminal strip. The detector terminal strip and the alarm 1 relay terminal strip may be removed by grasping them with your fingers if the adjacent terminal strips have been removed.
7. Guide multi conductor shielded cable or cables or wires in conduit through the top conduit hub of the junction box. The number of cables or wires needed will depend on whether the M2 is wired to a gas monitoring controller or just to power, whether any relays are used, and whether the Modbus output is used.

NOTE: If the M2 is being wired to a PLC or DCS device, see “Appendix B: PLC and DCS Device Wiring” on page 40, then continue with step 8.

Use the following recommendations to determine how to wire the M2:

- If Modbus connections will not be used and only the PWR/SIG connections will

be used, use a two or three conductor shielded cable or two or three wires in conduit for connections to the power/signal terminal strip depending on whether or not the signal (S) terminal is used.

Table 3: Wire Size for PWR/SIG Connections

Max Distance to Controller w/ 18 Gauge Wire	Max Distance to Controller w/16 Gauge Wire	Max Distance to Controller w/14 Gauge Wire
2,500 ft.	5,000 ft.	8,000 ft.

- If the PWR/SIG connections and one or more relays are used, route the connections to the M2 in conduit. Use shielded cable in the conduit for the PWR/SIG connections and unshielded cable or individual wires for the relay connections. Make sure any wire or cable used for relay wiring is appropriately rated for the power that it will carry.

NOTE: If shielded cable is used for the PWR/SIG connections, leave the cable shield's drain wire insulated and disconnected at the M2. You will connect the opposite end of the cable's drain wire at the controller or device.

- If the M2 will be wired into a Modbus network, see "Chapter 8: RS-485 Modbus Output" on page 29.

See Figure 5 below for field wiring connections to the M2.

CAUTION: Do not connect 24 VDC power to a 12 VDC M2.

WARNING: If the M2 is installed in a hazardous location, use appropriately rated conduit, conduit fittings, and construction technique.

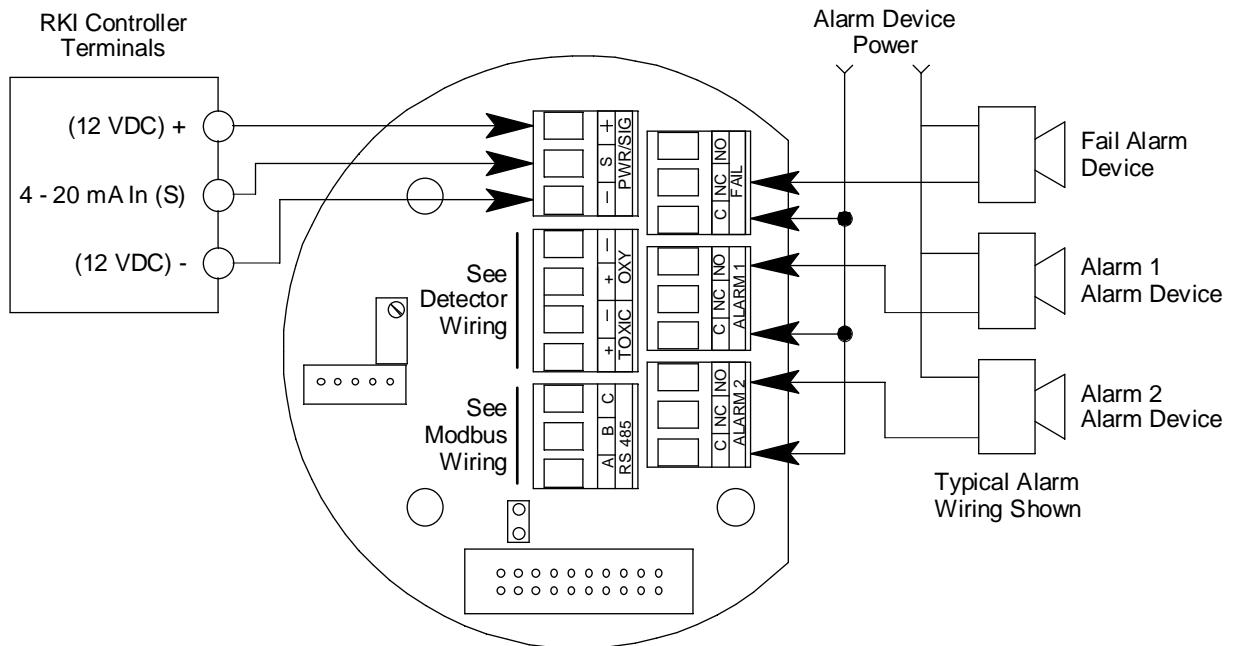

Figure 5: Wiring the M2 to a Controller and Alarm Devices

8. Re-install the control PCB (and ribbon cable if necessary). Be sure the ribbon cable is routed down below the control PCB so it will not be damaged by the cover when it is screwed back on.
9. Secure the junction box cover to the junction box.
10. Make controller, device, and relay connections as appropriate. If shielded cable is used for the PWR/SIG connections, connect the cable shield's drain wire to an available chassis ground at the gas monitoring controller, recording device, or programmable controller.

Start Up

Introducing Incoming Power

1. Complete the installation procedures described earlier in this manual.
2. Verify that all wiring connections are correct and secure.
3. Turn on the incoming power.
4. If necessary, turn on the controller or other monitoring device that is connected to the M2.
5. The LCD display will indicate the firmware version when the M2 is first powered up and will then count down a one minute warm-up period before normal operation begins. During normal operation, the display will indicate the target gas and current gas reading. Verify that the display is indicating the target gas and current gas reading after the warm-up period is complete and normal operation begins.

METHANE
0 %LEL

CAUTION: Allow the M2's detector to warm up for 15 minutes before you continue with the next section, "Adjusting the Fresh Air Reading."

Adjusting the Fresh Air Reading

When the M2 is shipped from RKI Instruments, Inc. it is factory calibrated. If a full calibration is desired at startup, see "Calibration" on page 25.

Verify that the M2 is in a fresh air environment (environment known to be free of the target gas and combustible or toxic gas vapors and of normal oxygen content, 20.9%).

CAUTION: If you suspect the presence of combustible gas, toxic gas, or that the oxygen content is not normal in the monitoring environment, use the calibration kit and the zero air calibration cylinder to introduce "fresh air" to the detector and verify an accurate fresh air setting. See "Calibration" on page 25 for instructions on how to use a zero air cylinder when performing a fresh air adjustment.

Non-Intrusive Fresh Air Signal Adjustment

If the M2 is installed in a classified area and non-intrusive zero adjustment is required, follow the instructions below, but do not remove the junction box cover. Use the magnetic wand accessory to actuate the magnetic switches instead of pushing the control switch buttons. To actuate a magnetic switch and perform the same operation as pressing a

control switch button, touch the magnet in the end of the magnetic wand to the M2's glass cover directly above the magnetic switch you wish to actuate. Touching the glass and removing the wand is the same as pressing and releasing a button. Touching the glass and keeping the wand in place is the same as pressing and holding a button.

WARNING: *The M2 is not an active gas monitoring device during the calibration procedure. The 4-20 mA output signal will “freeze” at 3.5 mA and all relays will remain in their non-alarm state while the M2 is in Calibration Mode. The output signal will not indicate current readings and the relays will not resume operating normally until the M2 is in normal operation again.*

NOTE: While in the calibration program, if there is no switch activity for the calibration time-out period the unit will return to normal operation. The factory set time-out is 15 minutes. If you want a different time-out period, see “Viewing & Changing M2 Parameters” on page 17 for instructions to change the calibration time-out.

Adjusting the Fresh Air Reading

1. While in normal operation, press and hold the UP/YES button for 5 seconds to enter Calibration Mode. Release the button when the following screen appears.

Calib? YES/NO

2. Press and release the UP/YES button to continue. The display will indicate the target gas and **CAL Mode** for a few seconds before showing **FreshAir Adjust?**.
3. Press and release the UP/YES button. **ENTER** will alternate with **FreshAir** on the top display line and the current gas reading will be on the bottom display line.
4. Press and release the ENTER button. The M2 will perform a zero operation and the display will indicate **SPAN w/Cal Gas?**.
5. Press and release the DOWN/NO button. The display will indicate **Leaving CAL Mode** and the M2 will return to normal operation.

Chapter 4: Operation

Overview

This chapter describes the M2 in normal operation. This chapter also describes the M2 in alarm 1, alarm 2, and fail conditions and suggests response to these conditions.

Normal Operation

Normal operation is defined as follows:

- The start-up procedure is complete.
- The M2 is not indicating an alarm 1, alarm 2, or fail condition.
- The M2 is not in Calibration, Configuration, or Gas Type modes.

During normal operation, the M2 simultaneously displays the current gas reading, unit of measure, and target gas. The example below illustrates a typical LEL M2.

METHANE 0 %LEL

Information Screen

The Information Screen displays the M2's operating voltage and firmware and hardware information. To display the Information Screen, do the following:

1. Press and hold the DOWN/NO button for 3 seconds. The Information Screen will appear.

12.1V v5.0L 1B

2. Continue holding the DOWN/NO button to keep the Information Screen on the display. The top line indicates the operating voltage that is connected to the M2. The second line indicates the firmware that is running, version 5.0 in this example, and the M2's hardware version, version 1B in this example. This information may be useful if you need to contact the factory with questions about the M2.
3. Release the DOWN/NO button when you are done viewing the Information Screen. The display will return to the normal operation screen within a couple of seconds.

4 - 20 mA Signal Output Operation

The output at the S terminal of the power/signal terminal strip is a 4 - 20 mA signal that is proportional to the detection range of the detector head. During normal operation, this signal tracks the gas concentration on the LCD.

There are several circumstances where the signal output will not track the display reading but will behave as follows:

- When the M2 is in its warm-up period, the signal output will be fixed at 3.5 mA (zero).
- When the M2's gas type is changed, the M2 will enter Configuration Mode for you to verify the parameter settings. When you exit Configuration Mode, the display will indicate **NEEDS CALIBRATION** and will continue to indicate this until Calibration Mode is entered and a calibration is performed. In this situation, the signal output will be fixed at 3.5 mA from the time Gas Type Mode is entered until the M2 is calibrated and returns to normal operation.
- If you enter Calibration Mode, Configuration Mode, Gas Type Mode, or Modbus Mode, the signal output will be fixed at 3.5 mA until the M2 returns to normal operation.
- If the M2's input power decreases below 10.5 volts so that the M2 is in a low power alarm, the signal output is fixed below 2.4 mA until the low power alarm is cleared.
- If the M2 goes into a fail condition, after a 30 second delay, the signal output is fixed below 2.4 mA until the fail alarm is cleared. During the 30 second delay, the signal output follows the detector output. In the case of a downscale reading, the display and the signal output continue to track the reading down to -99% of full scale (1.15 mA).

Alarm Indications

NOTE: The M2 includes alarm on and alarm off delay settings for alarm 1 and alarm 2. The alarm indications described in this section operate according to the factory set alarm settings. See Table 5 on page 18 for all the factory settings.

Table 4: Visual and Audible Alarm Indications

Condition	Cause	Visual Indication(s)
Alarm 1 ¹	Increasing gas reading at or above the alarm 1 setpoint	<ul style="list-style-type: none"> • A1 LED is on • Gas reading alternates with ALARM-1 message
Alarm 2 ¹	Increasing gas reading at or above the alarm 2 setpoint	<ul style="list-style-type: none"> • A2 LED is on • Gas reading alternates with ALARM-2 message
Fail	<ul style="list-style-type: none"> • Disconnected or misconnected detector wiring • Display reading at -10% of full scale or lower • Defective components 	<ul style="list-style-type: none"> • F LED is on • FAIL message replaces gas reading <p><i>NOTE: There is a 30 second delay on the fail condition.</i></p>
Low Power	DC power source less than 10.5 volts.	<ul style="list-style-type: none"> • F LED is on • LowPower message and actual voltage of incoming DC power
<p>* ¹<i>If the M2 is in both an alarm 1 and an alarm 2 condition, both alarm LEDs are on and the display alternates between the gas reading and the ALMS 1&2 message.</i></p>		

NOTE: You can select normally energized (N. EN) or normally de-energized (N. DE-EN) alarm 1 and alarm 2 relay settings in Configuration Mode. The following sections describe the standard factory setting for these relays which is N. DE-EN.

The fail relay is factory set as N. DE-EN and is not user-adjustable.

Alarm 1 Condition

Alarm 1 Condition Indications

When the gas reading reaches the alarm 1 setpoint, the M2 senses an alarm 1 condition. The M2 alerts you to an alarm 1 condition as follows:

- The A1 LED turns on.
- The gas reading alternates with the **ALARM-1** message.
- The alarm 1 relay energizes.

Responding to an Alarm 1 Condition

1. Follow your established procedure for a low level combustible gas condition.
2. After the gas reading falls below the alarm 1 setpoint, press the ENTER button to reset the alarm 1 circuit. Resetting the alarm 1 circuit turns off the A1 LED, resets the LCD, and de-energizes the alarm 1 relay.

NOTE: If the ENTER button is pressed while the M2 is in an alarm 1 condition, the A1 LED will flash but all other indications will remain unchanged.

You cannot de-energize the alarm 1 relay until the gas reading falls below the alarm 1 setpoint.

Alarm 2 Condition

Alarm 2 Condition Indications

When the gas reading reaches the alarm 2 setpoint, the M2 senses an alarm 2 condition. The M2 alerts you to an alarm 2 condition as follows:

- The A2 LED turns on.
- The gas reading alternates with the **ALARM-2** message.
- The alarm 2 relay energizes.

NOTE: If the M2 is in both an alarm 1 and alarm 2 condition, both the A1 and A2 LEDs will be on, the gas reading will alternate with the **ALMS 1&2** message, and both alarm relays will energize.

Responding to an Alarm 2 Condition

1. Follow your established procedure for a high level combustible gas condition.
2. After the gas reading falls below the alarm 2 setpoint, press the ENTER button to reset the alarm circuit. Resetting the alarm circuit turns off the A2 light, resets the LCD, and de-energizes the alarm 2 relay.

NOTE: If the ENTER button is pressed while the M2 is in an alarm 2 condition, the A2 LED will flash but all other indications will remain unchanged.

You cannot de-energize the alarm 2 relay until the gas reading falls below the alarm 2 setpoint.

Fail Condition

Fail Condition Indications

The M2 indicates a fail condition for any of the following:

- The detector wiring is disconnected or incorrectly connected.
- The display reading is -10% of full scale or lower.

When the M2 senses a fail condition, it alerts you as follows:

- The F LED turns on.
- The gas reading is replaced by the **FAIL** message.
- The fail relay de-energizes.

NOTE: The fail alarm has a 30 second delay.

Responding to a Fail Condition

Verify that the detector wiring is correctly and securely connected.

Low Power Alarm

Low Power Alarm Indications

The M2 senses a low power condition when the DC power source is 10.5 volts or less.

WARNING: *While in a low power condition, the M2 is not an active gas monitor.*

When the M2 senses a low power condition, it alerts you as follows:

- The F LED turns on.
- The message **LowPower** is indicated on the top line of the LCD and the input voltage is displayed on the bottom line of the LCD.
- The fail relay de-energizes.

NOTE: The low power alarm cannot be cleared using the ENTER button.

When the voltage increases to 10.7 volts, the low power alarm is cleared and the M2 will begin its warm-up sequence.

Responding to a Low Power Condition

1. Determine and correct the cause of the low power condition.
2. When the input power increases above 10.7 volts, the M2 will begin its warm-up sequence.
3. Verify that the M2 enters normal operation after its warm-up sequence. If necessary, perform a fresh air adjustment. See “Adjusting the Fresh Air Reading” on page 11.

Chapter 5: Configuration Mode

Overview

This chapter describes how to view and change M2 parameters using Configuration Mode. It is accessed using the program buttons.

Configuration Mode includes a 5-minute time-out feature. If you do not press a control button for 5 minutes, the M2 automatically returns to normal operation.

NOTE: If the M2 returns to normal operation because of a time-out, it enters a warm-up period just as it does when it is first turned on.

If you are installing a new M2, it has been setup at the factory. Use Configuration Mode only if you want to change the M2's setup. If you want to change the detector type see "Chapter 6: Gas Type Mode" on page 20.

Viewing & Changing M2 Parameters

1. While in normal operation, simultaneously press and hold the UP/YES and ENTER buttons for 5 seconds to enter Configuration Mode. Release the buttons when the following screen appears.

Enter
Config?

2. If you want to exit Configuration Mode, press and release the DOWN/NO button and the M2 will return to normal operation.

If you want to continue in Configuration Mode, press and release the UP/YES button. The target gas and the full scale will be displayed for a few seconds before the first adjustable parameter, the alarm 1 setpoint, is displayed.

3. If you want to change the currently displayed parameter, use the UP/YES and DOWN/NO buttons to adjust it to the desired setting, then press ENTER to continue to the next parameter.

If the currently displayed parameter is OK, press the ENTER button to proceed to the next parameter.

Table 5 lists the M2 parameters you can set. Table 5 also lists the factory set value for each parameter.

Table 5: Configuration Parameters

Parameter (Factory Set Value)	Description
ALARM-1 (level) (See "M2 Specifications" on page 2)	The gas reading at which the M2 initiates an alarm 1 condition.
ALARM-1 (activation) (Increase)	Indicates if the alarm 1 circuit is activated by gas readings increasing (Increase) or decreasing (Decrease) to the ALARM-1 Level.
ALARM-1 (relay action) (N. DE-EN)	If set as N. DE-EN , the alarm 1 relay is de-energized in normal operation and energizes when an alarm 1 condition is initiated. If set as N. EN , the alarm 1 relay is energized in normal operation and de-energizes when an alarm 1 condition is initiated.
ALARM-1 (relay reset) (LATCH)	If set as LATCH , you must press the ENTER button to reset the alarm 1 circuit after the alarm 1 condition passes. If set as SELF-RST , the M2 automatically resets the alarm 1 circuit after the alarm 1 condition passes.
A1 OnDy (alarm 1 on delay) (1 secs)	The amount of time the M2 delays activation of the alarm 1 circuit once an alarm 1 condition is initiated. It is settable in 1 second increments from 0 - 60 seconds, in 1 minute increments from 1 - 15 minutes, and in 15 minute increments from 15 - 60 minutes.
A1 OffDy (alarm 1 off delay) (0 sec.)	The amount of time the M2 delays turning off the alarm 1 circuit once an alarm 1 condition passes. This parameter appears only if the alarm 1 relay reset setting is set to SELF--RST . It is settable in 1 second increments from 0 - 60 seconds, in 1 minute increments from 1 - 15 minutes, and in 15 minute increments from 15 - 60 minutes.
ALARM-2 (level) (See "M2 Specifications" on page 2)	The gas reading at which the M2 initiates an alarm 2 condition.
ALARM-2 (activation) (Increase)	Indicates if the alarm 2 circuit is activated by gas readings increasing (Increase) or decreasing (Decrease) to the ALARM-1 Level.
ALARM-2 (relay action) (N. DE-EN)	If set as N. DE-EN , the alarm 2 relay is de-energized in normal operation and energizes when an alarm 2 condition is initiated. If set as N. EN , the alarm 2 relay is energized in normal operation and de-energizes when an alarm 2 condition is initiated.
ALARM-2 (relay reset) (LATCH)	If set as LATCH , you must press the ENTER button to reset the alarm 2 circuit after the alarm 2 condition passes. If set as SELF-RST , the M2 automatically resets the alarm 2 circuit after the alarm 2 condition passes.
A2 OnDy (alarm 2 on delay) (1 secs)	The amount of time the M2 delays activation of the alarm 2 circuit once an alarm 2 condition is initiated. It is settable in 1 second increments from 0 - 60 seconds, in 1 minute increments from 1 - 15 minutes, and in 15 minute increments from 15 - 60 minutes.
A2 OffDy (alarm 2 off delay) (0 sec.)	The amount of time the M2 delays turning off the alarm 2 circuit once an alarm 2 condition passes. This parameter appears only if the alarm 2 relay reset setting is set to SELF-RST . It is settable in 1 second increments from 0 - 60 seconds, in 1 minute increments from 1 - 15 minutes, and in 15 minute increments from 15 - 60 minutes.

Table 5: Configuration Parameters (Continued)

Parameter (Factory Set Value)	Description
ZeroSupp (2% LEL)	The zero suppression feature helps prevent “jumpy” readings near the fresh air reading. For example, if the zero suppression setting for a combustible detector is 2.0% LEL , the M2 will display a reading of 0% LEL for gas readings from -2% LEL to 2% LEL. It is settable from 0 to 6% of the detection range.
FILTER (5 secs)	The filter feature helps “smooth out” jumpy or noisy signals from the detector. You can set the filter from 0 seconds to 60 seconds in 5 seconds increments. The displayed gas reading is the average reading over the previous time period defined by the filter setting. So if the filter is set to 5 seconds, the displayed gas reading is the average over the past 5 seconds.
CAL Time (15 mins)	The calibration time-out sets the amount of time after the last button push while in Calibration Mode that the M2 will wait before returning to normal operation. If the calibration time-out is set to 15 mins , then the M2 will return to normal operation automatically 15 minutes after the last button push.
Auto Zero (Enabled)	If set to Enabled , the M2's firmware will monitor the zero (fresh air) reading and make automatic zero adjustments under precisely specified conditions if it determines that a reading change is due to normal sensor drift. If set to Disabled , the Auto Zero function is turned off.

4. When you have scrolled through all the adjustable parameters, **SAVE IT? YES/NO** appears on the display.
5. If you do not wish to save the adjustments and want to exit Configuration Mode, press and release the DOWN/NO button. The **DO OVER? YES/NO** message will display. Press and release the DOWN/NO button. The **ABORT? YES/NO** message will display. Press the UP/YES button to return to normal operation.

If you wish to change some of the adjustments made, press and release the DOWN/NO button. The **DO OVER? YES/NO** message will display. Press and release the UP/YES button. The **Re-do Config** message will display and the M2 will return to the first adjustable parameter. Go back to step 3 and continue.

If you wish to save the adjustments made, press and release the UP/YES button. **Config Saved** is indicated on the display for a few seconds and the M2 returns to normal operation.

Chapter 6: Gas Type Mode

Overview

This chapter describes how to use the Gas Type Mode to select the M2's gas type. The gas type determines the target gas and detection range.

The Gas Type Mode includes a 5-minute time-out feature. If you do not press a button for 5 minutes, the M2 automatically returns to normal operation.

NOTE: If the M2 enters normal operation because of a program time-out, it enters a warm-up period just as it does when it is first turned on.

Selecting the Gas Type

1. While in normal operation or during the warm-up sequence, press and hold the UP/YES and DOWN/NO buttons for five seconds. Release them when the following screen appears.

Select
GasType?

2. If you want to exit Gas Type Mode, press and release the DOWN/NO button. The display will indicate **NO CHANGE** and the M2 will return to normal operation.
If you want to continue in Gas Type Mode, press and release the UP/YES button. The top display line will indicate **GasType?** and the bottom display line will indicate the target gas choice.
3. Use the DOWN/NO button to scroll through the choices of target gas. Table 6 below lists the choices of target gas for the M2.

Table 6: M2 Gas Types

M2 type	Gas Type Choices	Detection Range
LEL	METHANE	0 - 100% LEL for all gas types.
	HYDROGEN	
	HEXANE	
	HC	

4. When the desired target gas is on the display, press and release the UP/YES button. The display will ask **SAVE IT? YES/NO**.

5. To discard the gas type change, press and release the DOWN/NO button. The display will ask **DO OVER? YES/NO**. Press the DOWN/NO button. The display will ask **ABORT? YES/NO**. Press the UP/YES button. The M2 will return to normal operation without changing the gas type.

To save the gas type, press and release the UP/YES button. The display will indicate **Gas Type Updated**, the display will indicate the target gas and the detection range for a few seconds, and then the M2 will enter Configuration Mode automatically so that the parameter settings in Configuration Mode can be verified or changed.

6. While in Configuration Mode press and release the ENTER button to accept the displayed parameter setting and move to the next one. Use the UP/YES and DOWN/NO buttons to adjust a setting. See “Chapter 5: Configuration Mode” on page 17 for a complete description of Configuration Mode.
7. When you have reviewed and accepted the last item in Configuration Mode by pressing the ENTER button, the display will ask **SAVE IT? YES/NO**.
8. To save the configuration settings, press and release the UP/YES button. The display will indicate **Config Saved** and the M2 will begin its warm-up sequence.

To discard the settings and review them again, press the DOWN/NO button. The display will ask **DO OVER? YES/NO**. Press the UP/YES button and the display will indicate **Re-do Config**, then display the target gas and the detection range for a few seconds before returning to Configuration Mode. Repeat steps 6 - 8 until the settings are as desired.

9. After the M2 completes its warm-up sequence, the display will indicate **CAL NEEDED**. Since the gas type has been changed, a successful calibration must be performed before the M2 can enter normal operation.
10. Press and release the UP/YES button to enter Calibration Mode. Normally, you must hold the UP/YES button for 5 seconds to enter Calibration Mode, but since a calibration is required, only a momentary push is needed to enter Calibration Mode after changing the gas type.
11. See “Calibration” on page 25 for calibration instructions.

NOTE: When calibrating an M2 after changing the gas type, the M2 will not ask if you want to calibrate, or whether you want to perform a fresh air adjustment, span adjustment or zero adjustment. Since a complete calibration is required, the calibration sequence will proceed without asking if you want to perform certain operations.

Chapter 7: Maintenance

Overview

This chapter describes procedures for performing preventive maintenance, troubleshooting, calibrating the M2, and replacing field replaceable parts.

Preventive Maintenance

This section describes a recommended preventive maintenance schedule to ensure the optimum performance of the M2. It includes daily, monthly, and quarterly procedures.

Daily

Verify a display reading of zero. Investigate significant changes in the reading.

Monthly

This procedure describes a test to verify that the M2 responds properly to the target gas.

NOTE: Performing a response test on the M2 may cause alarms. If you do not want external alarms to actuate, disable any external alarms during the response test to avoid unwanted external alarm indications.

NOTE: The following procedure assumes the use of a calibration kit which includes a calibration gas cylinder, a fixed flow regulator with an on/off knob, a calibration cup for the detector, and a short piece of sample tubing to connect the regulator to the calibration cup.

1. Disable all external alarms if external alarm indications are not desired during the response test.
2. Connect the calibration kit sample tubing to the calibration cup hose barb.
3. Screw the calibration cup onto the detector.
4. Connect the fixed flow regulator to the calibration cup using the sample tubing.
5. Screw the calibration gas cylinder into the fixed flow regulator.
6. Turn the regulator knob counterclockwise to open the regulator.
7. Allow calibration gas to flow for one minute.
8. Verify that the display reading is within $\pm 20\%$ of the gas concentration.

NOTE: If the reading is not within $\pm 20\%$ of the gas concentration, calibrate the M2 as described in “Calibration” on page 25.

9. Turn the regulator knob clockwise to close the regulator.
10. Unscrew the calibration gas cylinder from the fixed flow regulator and unscrew the calibration cup from the detector.

11. If external alarms have been disabled, enable them when the display returns to a normal fresh air reading.
12. Store the components of the calibration kit in a safe place.

Quarterly

Calibrate the M2 as described in “Calibration” on page 25. See “Calibration Frequency” on page 25 for a discussion of calibration frequency guidelines.

Troubleshooting

The troubleshooting guide describes symptoms, probable causes, and recommended action for problems you may encounter with the M2.

NOTE: This troubleshooting guide describes M2 problems only. If the M2 is connected to a controller, see the controller operator’s manual for problems you may encounter with the controller.

Table 7: Troubleshooting the Combustible Gas Detector

Condition	Symptom(s)	Probable Causes	Recommended Action
No Power	The display backlight is off and the display screen is blank.	<ul style="list-style-type: none"> • The power wiring is disconnected or misconnected. • The display cable is disconnected or misconnected. 	<ol style="list-style-type: none"> 1. Verify that the wiring to the power source or controller is correct and secure. 2. Verify that the ribbon cable connecting the terminal PCB to the control PCB is securely installed. This ribbon cable plugs into a connector on the top edge of the control PCB and on the bottom of the terminal PCB. 3. If the power difficulties continue, contact RKI for further instruction.
Frequent or Suspect Alarms	The M2 alerts you to frequent or suspect alarms while the fresh air readings remain on zero.	<ul style="list-style-type: none"> • The M2 is experiencing false readings due to RFI or EMI. • The detector wiring is disconnected, misconnected, or intermittent. 	<ol style="list-style-type: none"> 1. Verify that the M2 wiring is properly shielded. See “Wiring the M2 Transmitter” on page 9. 2. Verify that the detector wiring is correct and secure. 3. Increase the alarm on delay setting in Configuration Mode. 4. If the frequent or suspect alarm difficulties continue, contact RKI for further instruction.

Table 7: Troubleshooting the Combustible Gas Detector (Continued)

Condition	Symptom(s)	Probable Causes	Recommended Action
Flickering Display	The display reading flickers often.	<ul style="list-style-type: none"> The M2 is experiencing false readings due to RFI or EMI. The noise filter setting is too low. The zero suppression setting is too low. The display screen is malfunctioning. 	<ol style="list-style-type: none"> Verify that the M2 wiring is properly shielded. See "Wiring the M2 Transmitter" on page 9. Verify that the detector wiring is correct and secure. Increase the filter setting in Configuration Mode. Increase the zero suppression setting in Configuration Mode. If the display difficulties continue, contact RKI for further instruction.
Fail Condition	<ul style="list-style-type: none"> M2 indicates a fail condition. Controller indicates a fail condition 	<ul style="list-style-type: none"> The detector wiring to the terminal PCB is disconnected or misconnected. The wiring from the M2 to the controller is disconnected or misconnected. The detector fresh air signal is low enough to cause a fail condition. The detector is malfunctioning. The terminal or display PCB is malfunctioning. 	<ol style="list-style-type: none"> Verify that the detector wiring is correct and secure. Verify that the wiring between the M2 and the controller is correct and secure. Calibrate the M2. If the fail condition continues, replace the detector. If the fail condition continues, contact RKI for further instruction.
Slow or No Response/ Difficult or Unable to Calibrate	<ul style="list-style-type: none"> M2 responds slowly or does not respond to response test. Unable to successfully set the fresh air or span reading during calibration. M2 requires frequent calibration. <p><i>Note: Under "normal" circumstances, the detector requires calibration once every three months. See "Calibration Frequency" on page 25 for calibration frequency guidelines.</i></p>	<ul style="list-style-type: none"> The calibration cylinder is low, out-dated, or defective. The detector is malfunctioning. The terminal PCB is malfunctioning. 	<ol style="list-style-type: none"> Verify that the calibration cylinder contains an adequate supply of a fresh test sample. If the calibration/response difficulties continue, replace the detector. If the calibration/response difficulties continue, contact RKI for further instruction.

Calibration Frequency

Although there is no particular calibration frequency that is correct for all applications, a calibration frequency of every 3 to 6 months is adequate for most M2 applications. Unless experience in a particular application dictates otherwise, RKI Instruments, Inc. recommends a calibration frequency of every 3 months.

If an application is not very demanding, for example detection in a clean, temperature controlled environment where the toxic or combustible target gas is not normally present, and calibration adjustments are minimal at calibration, then a calibration frequency of every 6 months is adequate.

If an application is very demanding, for example if a combustible or toxic gas is present often and in significant concentrations or the environment is not well controlled, then more frequent calibration than every 3 months may be necessary. For combustible gas detection, if potential catalyst poisons are known or likely to be present, more frequent calibration than every 3 months will be necessary.

Calibration

This section describes how to calibrate the M2. It includes procedures to prepare for calibration, enter Calibration Mode, adjust the fresh air (zero) setting, adjust the span setting, and return to normal operation.

WARNING: *The M2 is not an active gas monitoring device during the calibration procedure. The 4-20 mA output signal will “freeze” at 3.5 mA and all relays will remain in their non-alarm state while the M2 is in Calibration Mode. The output signal will not indicate current readings and the relays will not resume operating normally until the M2 is in normal operation again.*

Preparing for Calibration

NOTE: The following procedure assumes the use of a calibration kit which includes a calibration gas cylinder, a zero air cylinder, a fixed flow regulator with an on/off knob, a calibration cup for the appropriate sensor, and a short piece of sample tubing to connect the regulator to the calibration cup.

NOTE: While in the calibration program, if there is no switch activity for the calibration time-out period the unit will return to normal operation. See “Viewing & Changing M2 Parameters” on page 17 for instructions to set the calibration time-out.

NOTE: The following procedure assumes that the target gas is present in a high enough concentration to affect the fresh air (zero) reading. If a fresh air environment can be verified, applying zero air to the detector is not necessary when setting the zero (span for oxygen) reading.

1. Connect the calibration kit sample tubing to the calibration cup hose barb.

2. Screw the calibration cup onto the detector.
3. Connect the fixed flow regulator to the calibration cup using the sample tubing.

Non-Intrusive Calibration

If the M2 is installed in a classified area and non-intrusive calibration is required, follow the instructions below, but do not remove the junction box cover. Use the magnetic wand accessory to actuate the magnetic switches instead of pushing the control switch buttons. To actuate a magnetic switch and perform the same operation as pressing a control switch button, touch the magnet in the end of the magnetic wand to the M2's glass cover directly above the magnetic switch you wish to actuate. Touching the glass and removing the wand is the same as pressing and releasing a button. Touching the glass and keeping the wand in place is the same as pressing and holding a button.

Calibration Gas Response Memory Feature

The M2 has the capability to “remember” the detector’s response to the calibration gas after the gas is removed from the detector during the fresh air and span adjustment procedure. This feature enables one person to perform calibration if the detector is mounted remotely from the M2. When zero air is applied to the M2 during a fresh air adjustment, the M2 will freeze the display reading at the lowest response and the M2 will continue to display this reading and retain it in its memory until the fresh air adjustment procedure is completed. When calibration gas is applied to the M2 during a span adjustment, the M2 will freeze the display reading at the highest response to the calibration gas. The calibration gas can then be removed and the M2 will continue to display this reading and retain it in its memory until the span adjustment procedure is completed.

Adjusting the Fresh Air Reading

1. While in normal operation, press and hold the UP/YES button for 5 seconds to enter Calibration Mode. Release the button when the following screen appears.

Calib? YES/NO

2. If you want to continue with calibration, press and release the UP/YES button. The display will indicate the target gas and **CAL Mode** for a few seconds before showing **FreshAir Adjust?**.

If you want to exit Calibration Mode, press and release the DOWN/NO button. The M2 will indicate **Leaving CAL Mode** and then return to normal operation.

3. To continue with adjusting the fresh air reading, press and release the UP/YES button. **ENTER** will alternate with **FreshAir** on the top display line and the current gas reading will be on the bottom display line.

To skip adjusting the fresh air reading, press and release the DOWN/NO button. The display will indicate **SPAN w/Cal Gas?**. Skip to the next section, “Adjusting the Span Setting”.

4. Screw the zero air cylinder into the fixed flow regulator.
5. Turn the regulator knob counterclockwise to open the regulator.
6. Allow zero air to flow for two minutes. If there was gas present causing a reading on the M2, the reading should decrease and stabilize after two minutes.
7. Turn the regulator knob clockwise to close the regulator.

8. Unscrew the zero air cylinder from the fixed flow regulator leaving the calibration cup on the detector. The M2 will continue to display the minimum gas response on the display and retain the response level in its memory.
9. Press and release the ENTER button. The M2 will perform a fresh air adjustment and the display will indicate **SPAN w/Cal Gas?**.

NOTE: If the fresh air adjustment fails, see “Troubleshooting” on page 23 for recommended actions.

Adjusting the Span Setting

1. If you want to continue with adjusting the span setting, press and release the UP/YES button. **APPLY** will alternate with **SPAN Gas** on the top display line and the current gas reading will be on the bottom display line.
If you want to skip adjusting the span reading, press and release the DOWN/NO button. The display will indicate **Leaving Cal Mode** and the M2 will return to normal operation.
2. Screw the calibration gas cylinder into the fixed flow regulator.
3. Turn the regulator knob counterclockwise to open the regulator.
4. Allow calibration gas to flow for two minutes. The gas reading should be stable after two minutes.
5. Turn the regulator knob clockwise to close the regulator.
6. Unscrew the calibration gas cylinder from the fixed flow regulator and unscrew the calibration cup from the detector. The M2 will continue to display the maximum gas response on the display and retain the response level in its memory.
7. Adjust the gas reading up or down to match the calibration gas cylinder concentration by using the UP/YES and DOWN/NO buttons, then press and release the ENTER button.
8. The M2 will perform a span operation. The display will indicate **SPAN Gas PASS** for a few seconds, then indicate **SPAN Gas SAVED** before indicating **Leaving CAL Mode** for a few seconds.

NOTE: If the span adjustment fails, see “Troubleshooting” on page 23 for recommended actions.

9. The display will now alternate between the normal operation screen and the message **REMOVE CAL GAS** for 1 minute. If the calibration gas has not been removed from the detector, remove it now to avoid unwanted alarms.
During this 1 minute period, the signal output will remain fixed at 3.5 mA and the relays will remain in their non-alarm state to avoid unwanted alarms while the calibration gas clears from the detector. At the end of the 1 minute period, the **REMOVE CAL GAS** message will stop appearing and the M2 will return to normal operation.
10. Store the components of the calibration kit in a safe place.

Replacing Components of the M2

Replacing LEL Detector

1. Turn off or disconnect power to the M2.
2. Remove the junction box cover.
3. Grasp the control PCB by its edges.
4. Gently pull until the control PCB is pulled away from the banana jacks. Take care not to pull too hard and damage the cable which connects the control and terminal PCB's.
5. Let the control PCB hang by the cable. The terminal strips are now visible on the terminal PCB. The control PCB may be left hanging while wiring is done. If desired, the control PCB may be disconnected from the cable and set aside while wiring.
6. Remove the detector terminal strip from its socket.
7. Disconnect the detector leads from the detector terminal strip. Note the position of the color-coded leads as you remove them.
8. Unscrew the detector from the junction box.
9. Guide the replacement detector leads through the bottom conduit hub of the junction box, then screw the mounting threads of the detector into the conduit hub.
10. Connect the detector leads to the detector terminal strip as follows:
Red wire to terminal labeled LEL RED, white to terminal labeled LEL WHT, green wire to terminal labeled LEL GRN, black wire to terminal labeled LEL BLK.
11. Re-install the detector terminal strip into its socket.
12. Re-install the control PCB (and ribbon cable if necessary). Be sure the ribbon cable is routed down below the control PCB so it will not be damaged by the cover when it is screwed back on.
13. Secure the junction box cover to the junction box.
14. Turn on or reconnect power to the M2.

CAUTION: *Allow the replacement detector to warm up for 15 minutes before you continue with the next step.*

15. Calibrate the replacement detector as described in "Calibration" on page 25.

Chapter 8: RS-485 Modbus Output

Overview

This chapter describes the M2's RS-485 Modbus output and how to configure the M2 to make use of it. It also discusses how to wire the M2 into a Modbus system.

The M2 provides an RS-485 serial communications interface. It is a Modbus Slave Device, supporting 2-wire RS-485 Modbus RTU serial communications.

Wiring the M2 in a Modbus System

When wiring the M2 into a Modbus system, adhere to standard Modbus wiring practices per the Modbus Over Serial Line Specification and Implementation Guide V1.0 or later. This document can be found online at www.modbus.org/specs.php.

The Modbus protocol supports a maximum of 247 unique slave addresses (1-247). The M2's line driver provides for up to 128 M2s to be connected together without the need for a repeater. Figure 6 & Figure 7 below illustrate typical M2 wiring configurations. If more than 128 M2s need to be connected together, RS-485 repeater(s) should be used such that no more than 128 M2s reside on any given network segment.

CAUTION: *The network segment can only support 128 units if RKI M2s are being used. The use of any other instruments will lower the number of units that may reside on any given network segment.*

NOTE: Only M2s produced after November 2010 have the capability to support a 128-unit segment. M2s produced before November 2010 can only support a 32-unit segment.

The MODBUS terminal strip is located on the terminal PCB (see Figure 2). The following signals are available at the Modbus terminal strip:

Table 8: Modbus Terminal Strip Signals

Modbus Terminal Label (RS-485 Name)	Modbus Signal Name
A	D0
B	D1
C	Common

Termination Jumper

The M2 includes a 2-pin termination header (see Figure 2) that is used when the M2 is used in a Modbus system. Every M2 is supplied with a termination jumper (a jumper block) installed onto this header. If the M2 is not used in a Modbus system, this jumper has no function. When the M2 is installed in a Modbus system, this jumper must be

installed in an M2 that is at the end of a Modbus line. Any M2 in a Modbus system that is not at the end of a line must have the termination jumper removed (see Figure 6 & Figure 7 below).

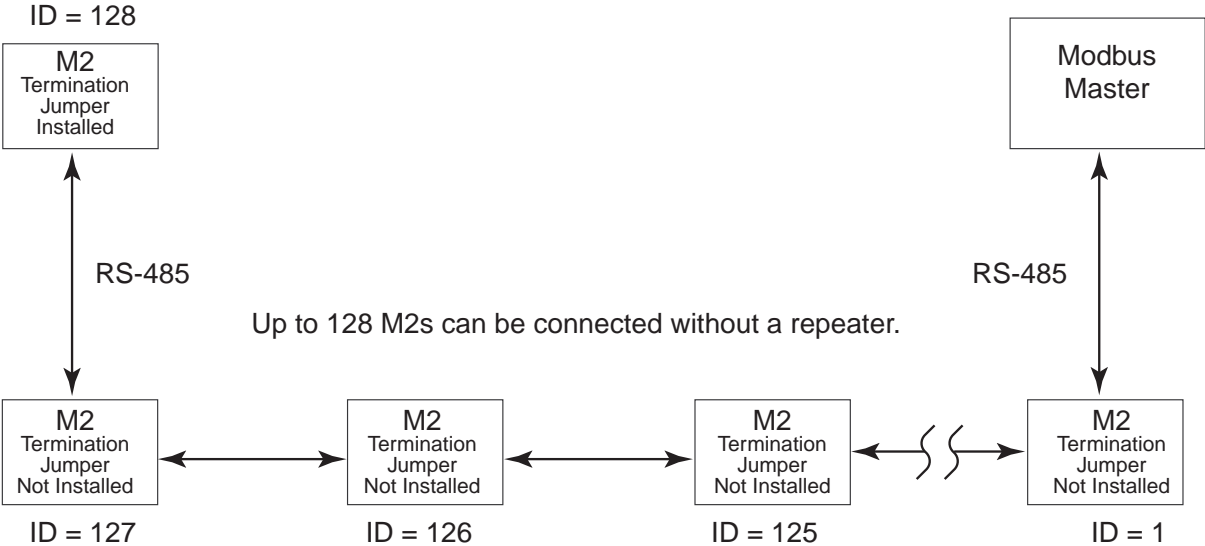
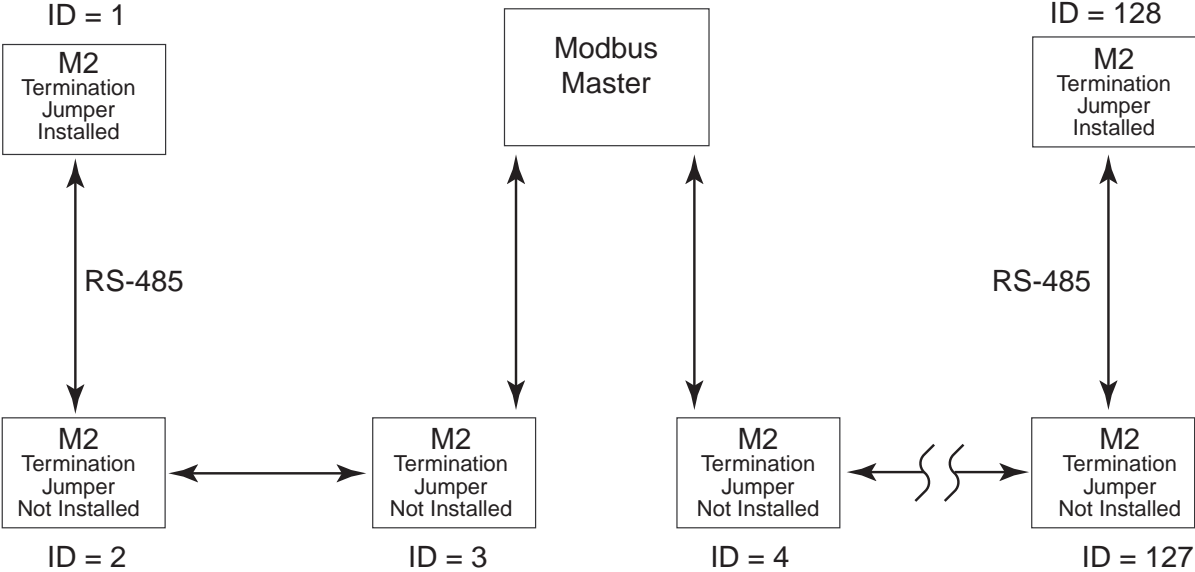

Figure 6: Multiple M2s in a Daisy Chain Configuration



Up to 128 M2s can be connected without a repeater.

Figure 7: Multiple M2s in a Two Branch Configuration

Using the M2 in a 4-wire Modbus System

The M2 is a 2-wire Modbus RTU device. It can be used with a 4-wire Modbus controller if the system wiring is modified as follows:

- Connect the controller's TxD0 and RxD0 wires together and use this connection as the 2-wire Modbus D0 signal.
- Connect the controller's TxD1 and RxD1 wires together and use this connection as the 2-wire Modbus D1 signal.
- Connect these D0 and D1 signals and the common wire from the controller to the 2-wire Modbus Network of M2s.
- Manage any pull-up, pull-down, and/or termination jumpers as appropriate for a 2-wire Modbus network.

Modbus Mode

Modbus Mode allows you to configure various parameters relating to the Modbus setup of the M2. Modbus Mode includes a 5-minute time-out feature. If you do not press a control button for 5 minutes, the M2 automatically returns to normal operation.

NOTE: If the M2 returns to normal operation because of a time-out, it enters a warm-up period just as it does when it is first turned on.

1. While in normal operation, simultaneously press and hold the DOWN/NO and ENTER buttons for 5 seconds to enter Modbus Mode. Release the buttons when the following screen appears.

Set Up
Modbus?

2. To exit Modbus Mode, press and release the DOWN/NO button. The M2 will return to normal operation.
To continue in Modbus Mode, press and release the UP/YES button. The current ENABLED/DISABLED setting will appear.
3. If you want to change the currently displayed parameter, use the UP/YES and DOWN/NO buttons to adjust it to the desired setting, then press ENTER to continue to the next parameter.

If the currently displayed parameter setting is OK, press the ENTER button to proceed to the next parameter.

Table 9 lists the M2 Modbus Mode parameters you can set. Table 9 also lists the factory set value for each parameter.

Table 9: Configuration Parameters

Modbus Mode Parameter	Available Settings & Description
Enabled/Disabled	Can be set to ENABLED or DISABLED (factory setting). Enables or disables the Modbus output.
Slave ID	The Slave ID can be set to values from 1 (factory setting) to 247. The M2 will only receive messages from the Master which are addressed to this Slave ID (except for broadcast messages which are received by all slaves).
Baud Rate	Can be set to 1200, 2400, 4800, 9600 (factory setting), 14440, & 19200
Parity	EVEN (factory setting), ODD, NONE
Response Delay	The response delay can be set from 0 (factory setting) to 20 mS. This is an optional additional delay inserted by the M2 prior to returning a response message to the Master. It may be helpful in some installations where the Master's preparedness to receive responses might be delayed.

4. When you have scrolled through all the adjustable parameters, **SAVE IT? YES/NO** appears on the display.
5. If you do not wish to save the adjustments, press and release the DOWN/NO button. The **DO OVER? YES/NO** message will display. Press and release the DOWN/NO button. The **ABORT? YES/NO** message will display. Press the UP/YES button to return to normal operation.

If you wish to change some of the adjustments made, press and release the DOWN/NO button. The **DO OVER? YES/NO** message will display. Press and release the UP/YES button. The **Re-do MB Setup** message will display and the M2 will return to the first adjustable parameter. Go back to step 3 and continue.

If you want to save the adjustments made, press and release the UP/YES button. **Modbus Saved** is indicated on the display for a few seconds and the M2 returns to normal operation.

NOTE: All M2s on a Modbus network must be configured with the same baud rate and parity, and each M2 must have a unique slave ID. For an M2 to participate on a network, the ENABLED/DISABLED setting must be set to ENABLE.

Supported Modbus Functions

The M2 supports Function Code 03: Read Holding Registers and Function Code 16: Write Registers. The register assignments detailed below were implemented in M2 firmware version 5.0. Please see revision 0 of the 12 V M2 manual if you have an M2 with a firmware version previous to 5.0.

WARNING: *Do not attempt to use registers according to the instructions below with units that have firmware versions previous to 5.0. For the Modbus register assignments of M2s with firmware previous to 5.0, see revision 0 of the 12 VDC M2 Operator's Manual. The firmware version is shown on the Information Screen described on page 13.*

Function Code 03: Read Holding Registers

There are a total of 40 registers available to be read via this Function Code.

Registers 1 - 2

The format (bit & field assignments) for registers 1 - 2 is shown below in Table 10 and Table 11.

Table 10: Register 1, Numerical Reading with Sign & Decimal Point Bit & Field Assignments

Bit(s)	Value & Field
[15]	<u>Sign of Reading</u> 0 = Positive 1 = Negative
[14:13]	<u>Format of Reading</u> 0 = XXX (no decimal point) 1 = XX.X 2 = X.XX 3 = .XXX
[12:0]	Numerical value of display reading (8000 max)

Table 11: Register 2, Operating State, Alarms & Relays Bit & Field Assignments

Bit(s)	Value
[15:12]	<u>Operating State</u> 0 = Undefined 1 = Initialization 2 = Normal 3 = Warm-up 4 = Fail 5 = Calibration 6 = Post-Calibration 7 = Low Power 8 = Setup

Table 11: Register 2, Operating State, Alarms & Relays Bit & Field Assignments (Continued)

Bit(s)	Value
[11]	<u>Gas Type Change</u> 0=Not Changed 1=Changed
[10]	<u>Configuration Change</u> 0=Not Changed 1=Changed
[9]	<u>Calibration Activity Flag</u> 0=No Calibration Activity 1=Calibration Activity Has Occurred
[8]	<u>Fail Status</u> 0 = Fail Not Asserted 1 = Fail Asserted
[7:6]	<u>Alarm 2 Status</u> 0 = No Alarm 1 = Unacknowledged Alarm 2 = Acknowledged Alarm 3 = Unused Code
[5:4]	<u>Alarm 1 Status</u> 0 = No Alarm 1 = Unacknowledged Alarm 2 = Acknowledged Alarm 3 = Unused Code
[3]	<u>Overscale Status</u> 0=Not Overscale 1=Overscale
[2]	<u>Fail Relay Status</u> 0 = Not Energized 1 = Energized
[1]	<u>Alarm 2 Relay Status</u> 0 = Not Energized 1 = Energized
[0]	<u>Alarm 1 Relay Status</u> 0 = Not Energized 1 = Energized

Register 3

Register 3 is the supply voltage (0.1 volt per count).

Registers 4 - 11

The 16 bytes in these registers contain the same ASCII text information that is displayed on the M2's LCD (not NULL terminated).

Register 12

Register 12 is the range (full scale readout).

Register 13

Register 13 is the alarm 1 set point.

The decimal point location is the same as specified in Register 1.

Register 14

Register 14 is the alarm 2 set point.

The decimal point location is the same as specified in Register 1.

Registers 15 - 19

Registers 15 - 19 are the Gas Name ASCII String (NULL Terminated).

Registers 20 - 22

Registers 20 - 22 are the Gas Units String (NULL Terminated).

Register 23

Register 23 is the alarm 1 trigger.

0=Decreasing

1=Increasing

Register 24

Register 24 is the alarm 1 normal relay state.

0=Normally De-Energized

1=Normally Energized

Register 25

Register 25 is the alarm 1 relay reset.

0=Latching

1=Self-Resetting

Register 26

Register 26 is the alarm 1 ON delay.

Integer values are in seconds.

Register 27

Register 27 is the alarm 1 OFF delay.

Integer values are in seconds.

Register 28

Register 28 is the alarm 2 trigger.

0=Decreasing

1=Increasing

Register 29

Register 29 is the alarm 2 normal relay state.

0=Normally De-Energized

1=Normally Energized

Register 30

Register 30 is the alarm 2 relay reset.

0=Latching

1=Self-Resetting

Register 31

Register 31 is the alarm 2 ON delay.

Integer values are in seconds.

Register 32

Register 32 is the alarm 2 OFF delay.

Integer values are in seconds.

Register 33

Register 33 is zero suppression.

Toxics and LEL: 0%-6% of full scale

The decimal point location is the same as specified in Register 1.

Register 34

Register 34 is noise filter.

Integer values in seconds.

0-60 in 5 second increments.

Register 35

Register 35 is calibration timeout in minutes (5, 10, 15, 20, 25, or 30).

Register 36

Register 36 is calibration month (upper byte) and day (lower byte).

This is zero based (e.g. January=0 and the 1st=0).

Register 37

Register 37 is the calibration year.

Register 38

Register 38 is the calibration outcome.

Upper=Gas Operation

Lower=Air Operation

Calibration Outcome Codes:

1=Sensor Missing

2=Sensor Too Weak

3=Signal Too Strong

4=Not Enough Span

5=Negative Reading

6=Span Gas Value Is Not OK

7=Calculated Zero Is Too Low

8=Calculated Zero Is Too High

9=Zero Failure

10=Span Failure

11=Calibration Is Overscale

12=LEL Sensor Offset Is Too High

13=LEL Null Operation failed

14=Operation Not Performed

Register 39

Register 39 is the auto-zero disable.
0=AutoZero Enabled
1=AutoZero Disabled

Register 40

Register 40 is the remote configuration register access level.
0=None
1=Alarm Reset

Function Code 16: Write Registers

There are 21 registers in Function Code 16 that can be used to write to the M2. This manual only describes Register 16 because it can be used to reset an alarm condition. For a complete description of Function Code 16, request Appendix C from RKI Instruments, Inc.

Register 16

Register 16 performs the same function as the ENTER button on the M2. It is useful for remotely silencing alarms. With the M2 in an alarm condition, bit [0] can be used to silence it.

Table 12: Register 16, Button Function

NOTE: Register 40 in Function Code 03, the remote configuration register, must be set to 1 in order for Register 16 to work.

Bit	Value & Field
[0]	ENTER (also used for "Alarm Reset") 0=Not Pressed 1=Pressed

Parts List

Table 13 lists replacement parts and accessories for the M2 Transmitter.

Table 13: Parts List

Part Number	Description
06-1248RK	Calibration kit sample tubing (3/16 in. x 5/16 in.; specify length when ordering)
07-0203RK	Rubber retaining boot for charcoal filter
18-0431RK-02	Junction box
33-7101RK	Charcoal filter disk
45-6132RK	Termination jumper
61-0140RK	LEL detector
71-0115RK	<i>M2 Transmitter for 12 VDC Operation Operator's Manual (this document)</i>
81-0002RK-01	Calibration cylinder, 50% LEL hydrogen; 34 liter steel
81-0007RK-01	Calibration cylinder, 15% LEL hexane; 34 liter steel
81-0012RK-01	Calibration cylinder, 50% LEL methane; 34 liter steel
81-0076RK-01	Zero air calibration cylinder, 34 liter steel
81-1050RK	Regulator, with gauge and knob, 0.5 liter/minute continuous flow, for combustible gas, nitrogen, and CO cylinders
81-1051RK	Regulator, with gauge and knob, 0.5 liter/minute continuous flow, for H ₂ S cylinder
81-1117RK	Calibration cup
NC-6234-01K	Hydrogen specific LEL detector

Appendix A: Control Button Quick Reference Guide

The M2's control buttons allow access to operational modes, resetting of alarms, and display of the Information Screen. Table 14 shows which button combinations perform these functions and which parameters are available for adjustment while in the operational modes. While in these modes, display prompts showing a "?" require you to respond by pressing either the UP/YES (for yes) or DOWN/NO (for no) button. To change parameter settings, use the UP/YES and DOWN/NO buttons to get the desired setting, then press and release the ENTER button to accept the setting.

Table 14: Control Button Quick Reference Chart

Mode Entered or Function Performed	Button Combination	Adjustable or Viewable Parameters
Alarm Reset	Press and Release ENTER	n/a
Show Information Screen	Press and Hold DOWN/NO	<ul style="list-style-type: none"> • Input Voltage • M2 Version/Revision Information
Calibration Mode	Press and Hold UP/YES for 5 seconds	<ul style="list-style-type: none"> • Fresh Air Adjust • Span (or Zero for Oxygen) Adjust with Calibration Gas
Configuration Mode	Press and Hold UP/YES & ENTER for 5 seconds	<ul style="list-style-type: none"> • Alarm Levels • Increasing or Decreasing Alarms • Normally Energized or Normally De-energized Relays • Latching or Self-resetting Alarms • Alarm On Delay • Alarm Off Delay (if self-resetting) • Zero Suppression • Noise Filter • Calibration Time-out Period
Gas Type Mode	Press and Hold UP/YES and DOWN/NO for 5 seconds	Gas Type
Modbus Mode	Press and Hold DOWN/NO and ENTER for 5 seconds	<ul style="list-style-type: none"> • Enable or Disable Modbus • Slave ID • Baud Rate • Parity • Response Delay

Appendix B: PLC and DCS Device Wiring

The M2 can be wired to a PLC or DCS device if desired.

1. Guide multi conductor shielded cable or cables or wires in conduit through the top conduit hub of the junction box. The number of cables or wires needed will depend on whether any relays are used and whether the Modbus output is used. Use the following recommendations to determine how to wire the M2:
 - If Modbus connections will not be used and only the PWR/SIG terminal strip connections will be used, use four conductor shielded cable or four wires in conduit for connections to the power/signal terminal strip.

Table 15: Wire Size for PWR/SIG Connections

Max Distance to Controller w/18 Gauge Wire	Max Distance to Controller w/16 Gauge Wire	Max Distance to Controller w/14 Gauge Wire
2,500 ft.	5,000 ft.	8,000 ft.

- If the PWR/SIG terminal strip connections and one or more relays are used, route the connections to the M2 in conduit. Use shielded cable in the conduit for the PWR/SIG connections and unshielded cable or individual wires for the relay connections. Make sure any wire or cable used for relay wiring is appropriately rated for the power that it will carry.

NOTE: If shielded cable is used for the PWR/SIG connections, leave the cable shield's drain wire insulated and disconnected at the M2. You will connect the opposite end of the cable's drain wire at the controller or device.

- If the M2 will be wired into a Modbus network, see "Chapter 8: RS-485 Modbus Output" on page 29.

CAUTION: Do not connect 24 VDC power to a 12 VDC M2.

See Figure 8 below for field wiring connections to the M2.

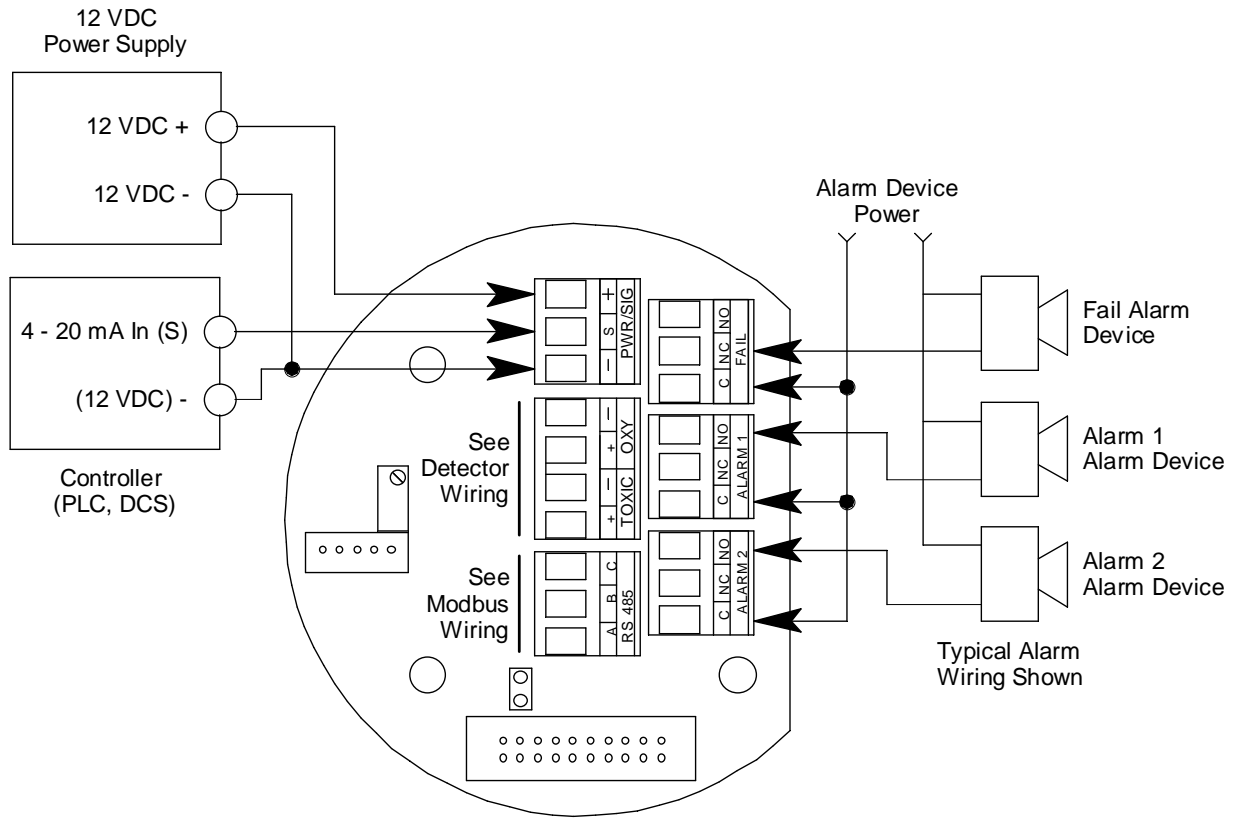

Figure 8: PLC and DCS Device Wiring

Appendix C: Function Code 16 Registers

The M2 supports Function Code 16 that allows writing to the M2. There are 21 registers in this Function Code. The register assignments detailed below were implemented in M2 firmware version 5.0. Please see revision 0 of the 12 VDC M2 manual if you have an M2 with a firmware version previous to 5.0.

WARNING: *Do not attempt to use registers according to the instructions below with units that have firmware versions previous to 5.0. For the Modbus register assignments of M2s with firmware previous to 5.0, see revision 0 of the 12 VDC M2 Operator's Manual. The firmware version is shown on the Information Screen described on page 13.*

Register 1

Register 1 is the alarm 1 set point.
Value must be an integer. Any decimals are omitted.

Register 2

Register 2 is the alarm 1 trigger.
0=Decreasing
1=Increasing

Register 3

Register 3 is the alarm 1 relay state.
0=Normally De-Energized
1=Normally Energized

Register 4

Register 4 is the alarm 1 relay reset.
0=Latching
1=Self-Resetting

Register 5

Register 5 is the alarm 1 ON delay.
Integer value is in seconds.

Register 6

Register 6 is the alarm 1 OFF delay.
Integer value is in seconds.

Register 7

Register 7 is the alarm 2 set point.
Value must be an integer. Any decimals are omitted.
The decimal point location is the same as specified in Register 1 of Function Code 03.

Register 8

Register 8 is the alarm 2 trigger.
0=Decreasing
1=Increasing

Register 9

Register 9 is the alarm 2 relay state.
0=Normally De-Energized
1=Normally Energized

Register 10

Register 10 is the alarm 2 relay reset.
0=Latching
1=Self-Resetting

Register 11

Register 11 is the alarm 2 ON delay.
Integer value is in seconds.

Register 12

Register 12 is the alarm 2 OFF delay.
Integer value is in seconds.

Register 13

Register 13 is the zero suppression.
Toxics and LEL: 0%-6% Full Scale
Value must be an integer. Any decimals are omitted.

Register 14

Register 14 is the noise filter.
Integer value is in seconds (0-60 in 5 second increments).

Register 15

Register 15 is the calibration timeout.
Value is in minutes (5, 10, 15, 20, 25, or 30).

Register 16

Register 16 is explained in “Supported Modbus Functions” in the M2 manual.

Register 17

Register 17 is the calibration month (MSB) and day (LSB).
This is zero-based (e.g. January=0 and the 1st=0).

Register 18

Register 18 is the calibration year.

Register 19

Register 19 is for clearing change flags. When parameters are changed at the M2, a flag is raised at the controller. This register can be used to clear those flags.

Table 16: Register 19, Clear Change Flags

Bit(s)	Value & Field
[15:2]	Unused
[1]	Write “1” to this bit to clear “Gas Type Changed” flag

Bit(s)	Value & Field
[0]	Write "1" to this bit to clear "Configuration Changed" flag

Register 20

Register 20 is the AutoZero Disable.

0=AutoZero Enabled

1=AutoZero Disabled

Register 21

Register 21 is the Remote Configuration Register.

0=No Remote Configuration

1=Reset Alarm