



INSTRUMENTS

65-2432RK-05
Carbon Monoxide Transmitter
Operator's Manual

Part Number: 71-0113RK

Revision: C

Released: 7/6/20

www.rkiinstruments.com

WARNING

Read and understand this instruction manual before operating detector. Improper use of the detector could result in bodily harm or death.

Periodic calibration and maintenance of the detector is essential for proper operation and correct readings. Please calibrate and maintain this detector regularly! Frequency of calibration depends upon the type of use you have and the sensor types. Typical calibration frequencies for most applications are between 3 and 6 months, but can be required more often or less often based on your usage.

Product Warranty

RKI Instruments, Inc. warrants gas alarm equipment sold by us to be free from defects in materials, workmanship, and performance for a period of one year from date of shipment from RKI Instruments, Inc. Any parts found defective within that period will be repaired or replaced, at our option, free of charge. This warranty does not apply to those items which by their nature are subject to deterioration or consumption in normal service, and which must be cleaned, repaired, or replaced on a routine basis. Examples of such items are:

- a) Absorbent cartridges
- b) Pump diaphragms and valves
- c) Fuses
- d) Batteries
- e) Filter elements

Warranty is voided by abuse including mechanical damage, alteration, rough handling, or repair procedures not in accordance with the operator's manual. This warranty indicates the full extent of our liability, and we are not responsible for removal or replacement costs, local repair costs, transportation costs, or contingent expenses incurred without our prior approval.

THIS WARRANTY IS EXPRESSLY IN LIEU OF ANY AND ALL OTHER WARRANTIES AND REPRESENTATIONS, EXPRESSED OR IMPLIED, AND ALL OTHER OBLIGATIONS OR LIABILITIES ON THE PART OF RKI INSTRUMENTS, INC. INCLUDING BUT NOT LIMITED TO, THE WARRANTY OF MERCHANTABILITY OR FITNESS FOR A PARTICULAR PURPOSE. IN NO EVENT SHALL RKI INSTRUMENTS, INC. BE LIABLE FOR INDIRECT, INCIDENTAL, OR CONSEQUENTIAL LOSS OR DAMAGE OF ANY KIND CONNECTED WITH THE USE OF ITS PRODUCTS OR FAILURE OF ITS PRODUCTS TO FUNCTION OR OPERATE PROPERLY.

This warranty covers instruments and parts sold to users by authorized distributors, dealers, and representatives as appointed by RKI Instruments, Inc.

We do not assume indemnification for any accident or damage caused by the operation of this gas monitor, and our warranty is limited to the replacement of parts or our complete goods.

Table of Contents

Overview	5
Specifications	5
Description	6
CO Detector	6
Amplifier	7
Junction Box	8
Installation	8
Mounting the CO Transmitter	8
Wiring the CO Transmitter to a Controller	10
Startup	12
Introducing Incoming Power	12
Setting the Zero Signal	12
Maintenance	13
Preventive Maintenance	13
Troubleshooting	13
Replacing Components of the CO Transmitter	14
Calibration Frequency	18
Calibration	18
Preparing for Calibration	18
Setting the Zero Reading	19
Setting the Response Reading	19
Returning to Normal Operation	20
Parts List	20

Overview

This manual describes the carbon monoxide (CO) transmitter. This manual also describes how to install, start up, maintain, and calibrate the transmitter. A parts list at the end of this manual lists replacement parts and accessories for the CO transmitter.

Specifications

WARNING: Do not use this product in a manner not specified in this instruction manual.

Table 1 lists specifications for the CO transmitter.

Table 1: Specifications

Target Gas	Carbon Monoxide (CO)
Area Classification	Explosionproof for Class I, Groups B, C, and D
Temperature Code	T6
Installation Category	Installation Category 1. Signal level, special equipment or parts of equipment, telecommunication, electronic, etc., with smaller transient overvoltages than Installation Category (Overvoltage Category) II (ref. IEC 664).
Input Voltage	11 VDC - 30 VDC
Sampling Method	Diffusion
Signal Output	4 to 20 mA
Detection Range	0 to 300 PPM (parts per million)
CO Detector Signal Output	0.3 mA at 0 ppm CO nominal 2.5 mA at 300 ppm CO nominal
Response Time	90% in 30 seconds
Accuracy	± 5% of reading or ± 5 ppm CO (whichever is greater)
Operating Temperature	23°F to 104°F (-5°C to 40°C)

NOTE: The following symbol on the detector label is a caution to the user to refer to this documentation for installation and operation instructions: 

WARNING: *When using the 65-2432RK-05, you must follow the instructions and warnings in this manual to assure proper and safe operation of the 65-2432RK-05 and to minimize the risk of personal injury. Be sure to maintain and periodically calibrate the 65-2432RK-05 as described in this manual.*

Description

This section describes the components of the CO transmitter. The transmitter consists of the CO detector, amplifier, and junction box.

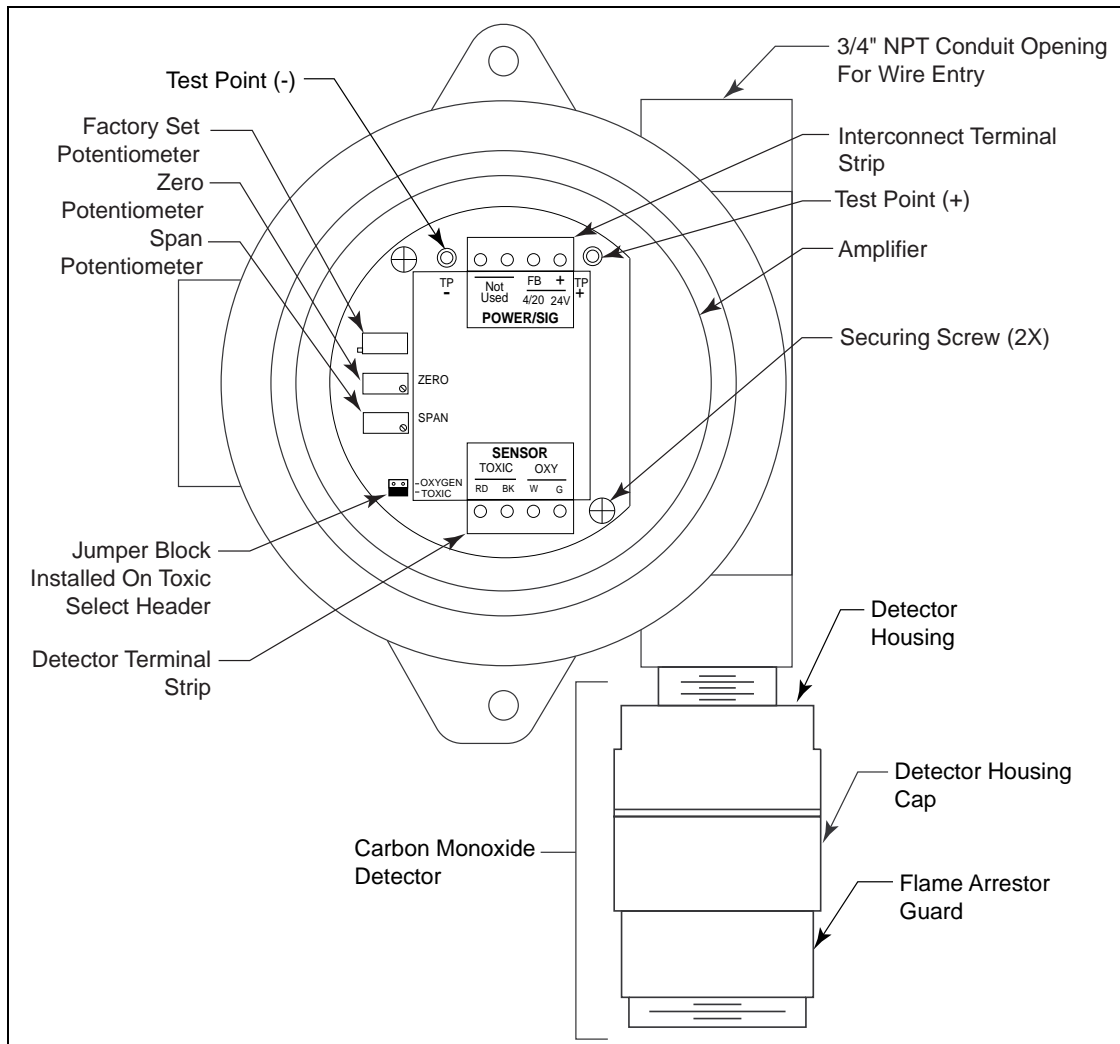

Figure 1: CO Transmitter Component Location

CO Detector

The CO detector includes the detector housing and sensor.

Detector Housing

The detector housing protects the sensing components within the housing. Use the mounting threads at the top of the housing to screw the CO detector into the bottom conduit hub of the junction box. Use the removable cap near the bottom of the housing to access the sensor for maintenance or replacement. The cap protects the sensor from damage and includes a flame arrestor which contains any sparks which may occur within the detector housing. A cap gasket seals the interface between the housing and cap. A flame arrestor guard is permanently bonded to the cap.

Two wires extend from the top of the detector housing. Use these wires to connect the CO detector to the amplifier. The housing includes a four-socket pattern. This socket pattern accepts the sensor's four pins to secure the sensor within the detector housing. A pre-amplifier, located between the sockets and two interconnect wires, conditions the sensor's signal before the signal reaches the amplifier.

Sensor

The sensor is secured within the sensor housing by the four pins. Through a series of chemical and electrical reactions, the sensor produces an electrical output that is proportional to the detector range of the transmitter.

Charcoal Filter

The disc-shaped charcoal filter is secured to face of the CO sensor with a rubber boot. The charcoal filter prevents interference gases (hydrogen sulfide [H₂S] and certain hydrocarbons) from producing false CO readings.

Amplifier

The amplifier converts the electrical output from the sensor to a 4 to 20 mA signal (that is proportional to the detection range) and transmits the signal to a gas monitoring controller. The amplifier includes the amplifier type selector, detector terminal strip, interconnect terminal strip, span pot, zero pot, and test points (see Figure 1).

Amplifier Type Selector

The amplifier type selector is near the bottom left corner of the amplifier. It is to the left of the detector terminal strip and below the span pot.

The amplifier included with the CO transmitter is designed for use with RKI's toxic gas and oxygen transmitters. The amplifier type selector determines for which transmitter the amplifier is intended. For CO transmitters, a jumper block is installed over the **TOXIC** selector (see Figure 1).

Detector Terminal Strip

The detector terminal strip is the four-point terminal strip near the bottom of the amplifier. Use the detector terminal strip to connect the CO detector to the amplifier.

NOTE: The CO detector is factory-wired to the amplifier. See the Installation section of this manual for all wiring procedures related to the transmitter.

Interconnect Terminal Strip

The interconnect terminal strip is the four-point terminal strip near the top of the amplifier. Use the interconnect terminal strip to connect the amplifier to a controller.

Span Pot

The span pot is on the left side of the amplifier. Of the three potentiometers, the span pot is bottom most. Use the span pot to adjust the transmitter's response output during the calibration procedure.

Zero Pot

The zero pot is above the span pot. Use the zero pot to adjust the transmitter's target gas-free output during the start-up and calibration procedures.

CAUTION: *The third potentiometer is factory-set. Do not adjust it.*

Test Points

The test points (labeled **TP-** and **TP+**) are on the left and right side of the interconnect terminal strip. The test points produce a 100 to 500 mV output that is proportional to the transmitter's 4 to 20 mA output. Use the test points and a voltmeter to measure the transmitter's output during the start-up and calibration procedures.

Junction Box

Use the junction box to install the CO transmitter at a mounting site that is remote from the controller. The junction box also protects the amplifier and wiring connections made to the amplifier. Use the two 3/4 in. conduit hubs to mount the detector to the junction box (bottom hub) and connect wiring from the amplifier to the controller (top hub).

NOTE: The CO detector and amplifier are factory-mounted to the junction box.

Use the junction box's two mounting holes to mount the CO transmitter to a vertical surface at the monitoring site. Use the cover on the front of the junction box to access the interior of the junction box.

Installation

This section describes procedures to mount the CO transmitter in the monitoring environment and wire the transmitter to a controller.

Mounting the CO Transmitter

1. Select a mounting site that is representative of the monitoring environment. Consider the following when you select the mounting site.
 - Select a site where the transmitter is not likely to be bumped or disturbed. Make sure there is sufficient room to perform start-up, maintenance, and calibration procedures.
 - Select a site where the target gas is likely to be found first.

NOTE: If your application does not require a specific mounting site, mount the transmitter at approximately breathing level.

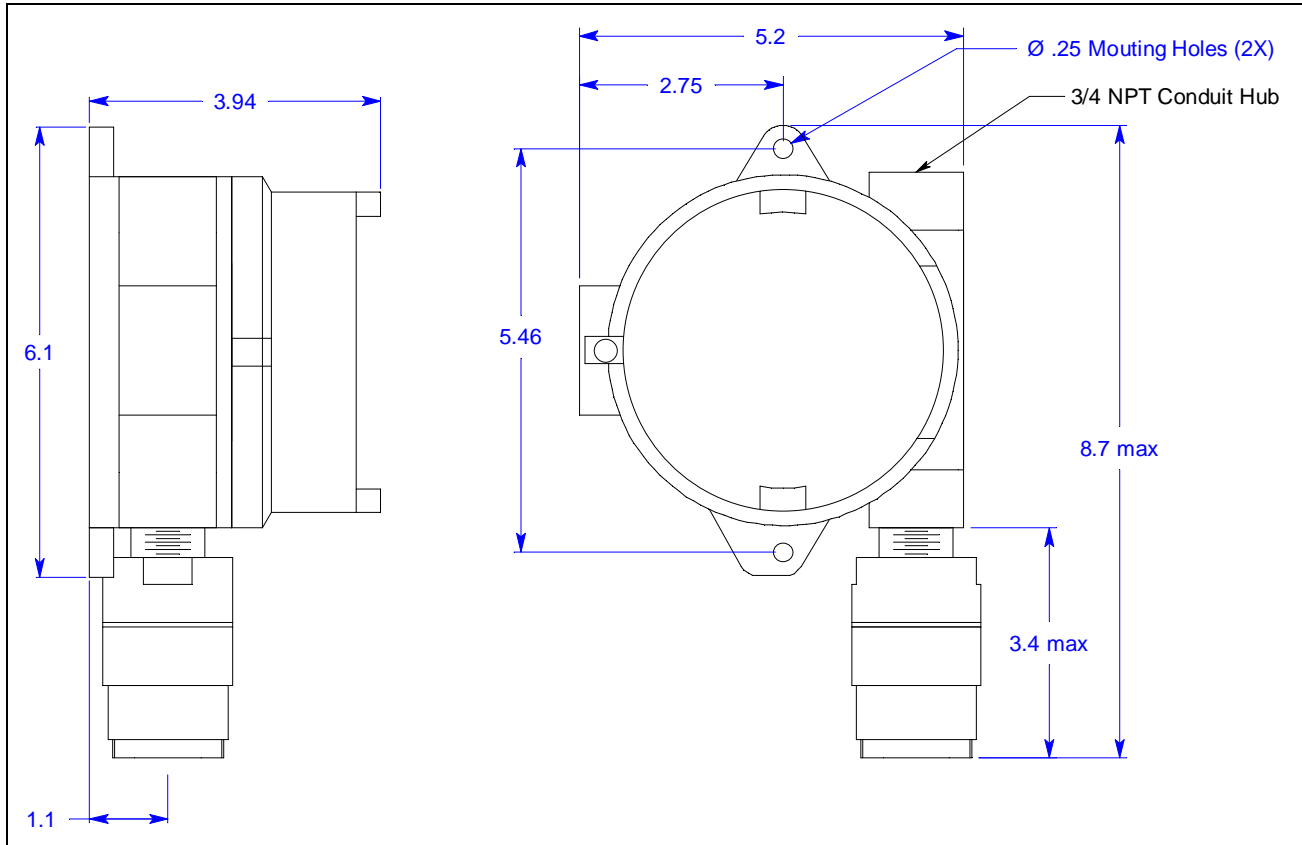

Figure 2: Mounting the CO Transmitter

If the CO detector is mounted to the junction box, skip to step 5. If not, continue with step 2.

NOTE: The CO detector is normally provided with a Killark HKB junction and an HFC lid rated explosion proof for Class I, Groups B, C, and D. This combination is shown in Figure 2 above. Any junction box with an internal volume less than or equal to 69 cubic inches and rated explosion proof for Class I, Groups B, C, and D may be used.

2. Remove the junction box cover.
3. Guide the two wires that extend from the top of the CO detector through the bottom conduit hub of the junction box.
4. Screw the CO detector into the bottom conduit hub of the junction box.
5. At the monitoring site, use #10 screws through the junction box's two mounting holes to secure the junction box to a vertical surface.

CAUTION: *Mount the CO transmitter with the detector facing down (see Figure 2).*

Wiring the CO Transmitter to a Controller

WARNING: *If the controller's construction is not explosion-proof, the controller must be installed in an ordinary location. Do not install a non-explosion-proof controller in a classified location.*

1. Turn off the controller.
2. Turn off or unplug incoming power to the controller.
3. Remove the junction box cover.
4. Verify that the detector leads are wired to the amplifier's detector terminal strip. If necessary, connect the detector leads to the detector terminal strip as shown in Figure 3.
5. Verify that the jumper block is installed over the **TOXIC** selector of the amplifier type selector as shown in Figure 3.
6. Guide a two-conductor, shielded cable or two wires in conduit through the top conduit hub of the junction box.

WARNING: *To maintain the explosion proof classification of the CO detector/junction box combination, a conduit seal must be used within 2 inches of the junction box conduit hub used for wiring to the controller. Adhere to your local electrical code when installing the conduit seal.*

7. Connect the two wires to the interconnect terminal strip as follows (see Figure 3).
 - Connect the positive wire to the terminal labeled **24V +**.
 - Connect the feedback wire to the terminal labeled **4/20 FB**.

CAUTION: *If using shielded cable, leave the drain wire insulated and disconnected at the transmitter. You will connect the opposite end of the cable's drain wire at the controller.*

8. Secure the junction box cover to the junction box.
9. Route the cable or wires leading from the CO transmitter through one of the conduit hubs at the controller housing.

CAUTION: *Do not route power and transmitter wiring through the same conduit hub. The power cable may disrupt the transmission of the transmitter signal to the controller.*

10. Connect the wires to the applicable controller transmitter terminal strip as shown in Figure 3.

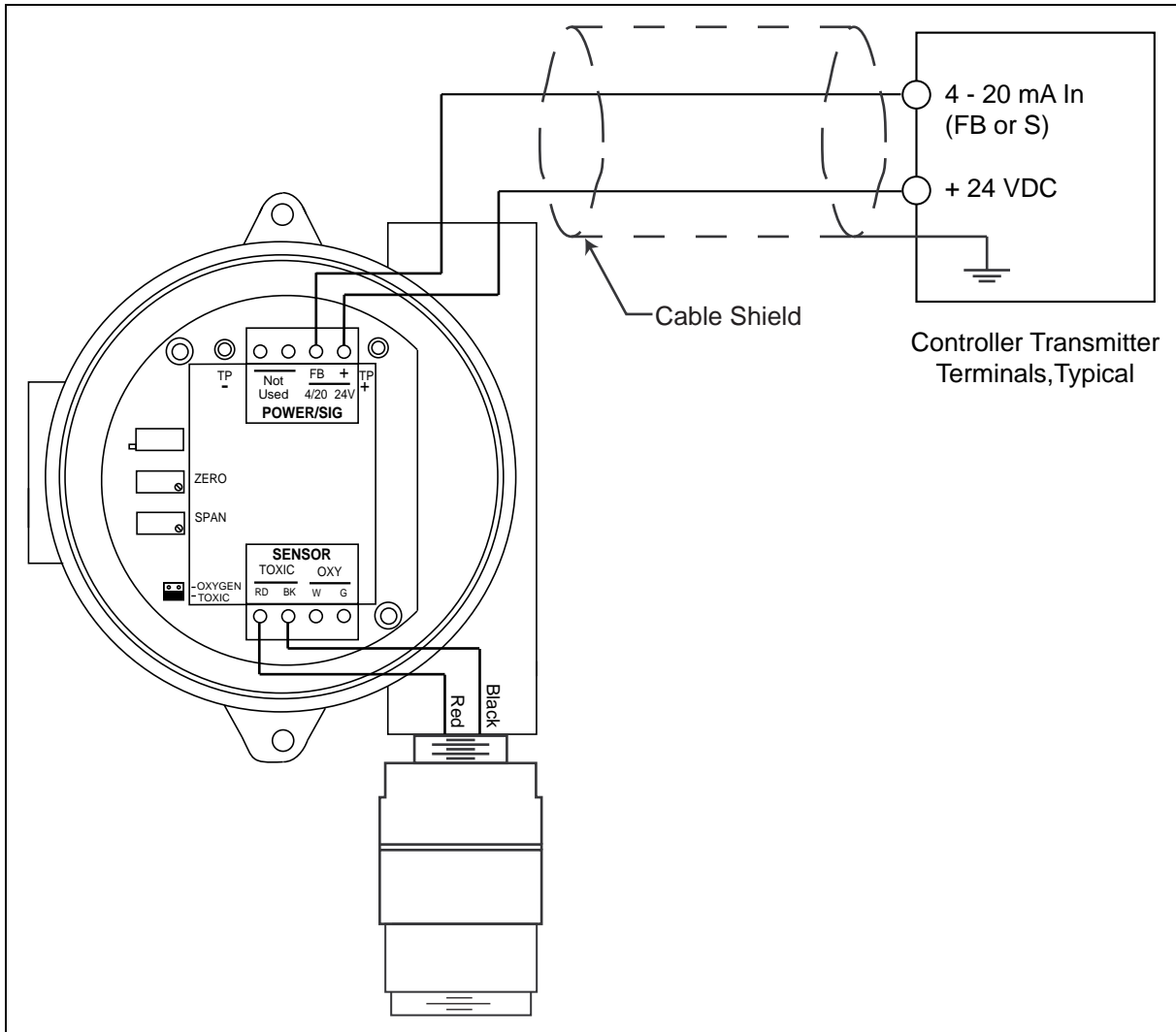

Figure 3: Wiring the CO Transmitter to a Controller

11. If shielded cable is used, connect the cable's drain wire to an available chassis (earth) ground at the controller. RKI controllers typically have a ground stud that can be used to ground the cable's drain wire.

Start Up

This section describes procedures to start up the CO transmitter and place the transmitter into normal operation.

Introducing Incoming Power

1. Complete the installation procedures described earlier in this manual.
2. Verify that the power wiring to the controller is correct and secure. Refer to the controller instruction manual.
3. Turn on or plug in the incoming power at the power source end, then turn on the controller.
4. Verify that the controller is on and operating properly. Refer to the controller instruction manual.

CAUTION: *Allow the transmitter to warm up for 5 minutes before you continue with the next section, "Setting the Zero Signal".*

Setting the Zero Signal

WARNING: *Do not remove the sensor cap or junction box cover while the circuits are energized unless the area is determined to be non-hazardous. Keep the sensor cap and junction box cover tightly closed during operation.*

NOTE: If you can verify that the detector is in a fresh air environment (environment known to be of normal oxygen content and free of toxic and combustible gases), it is not necessary to apply zero air when verifying or setting the fresh air reading.

The procedure below describes applying zero emission air, usually called zero air, using a calibration kit that includes a calibration cup, calibration gas, sample tubing, and a fixed flow regulator with an on/off knob. RKI Instruments, Inc. recommends using a 0.5 LPM (liters per minute) fixed flow regulator.

1. Unscrew and remove the junction box cover from the junction box.
2. Set a voltmeter to measure in the millivolt (mV) range.
3. Plug the voltmeter leads into the test points on the amplifier. Plug the positive lead into the test point labeled **TP+**; plug the negative lead into the test point labeled **TP-**.
4. Screw the calibration cup onto the bottom of the detector.
5. Screw the regulator into the zero air calibration cylinder.
6. Use the sample tubing to connect the regulator to the calibration cup.
7. Turn the regulator's on/off knob counterclockwise to open it. Gas will begin to flow.
8. Allow the gas to flow for 2 minutes.

9. Verify a voltmeter reading of 100 mV (± 2 mV).
10. If necessary, use a flat-blade screwdriver to adjust the span pot until the voltmeter reading is 100 mV (± 2 mV).
11. Turn the regulator's on/off knob clockwise to close it.
12. Unscrew the calibration cup from the detector.
13. Unscrew the regulator from the zero air calibration cylinder. For convenience, leave the sample tubing connected to the regulator and the calibration cup.
14. Store the components of the calibration kit in a safe and convenient place.
15. Remove the voltmeter leads from the test points.
16. Secure the junction box cover to the junction box.

Maintenance

This section describes maintenance procedures. It includes preventive maintenance, troubleshooting, and component replacement procedures.

Preventive Maintenance

This section describes a preventive maintenance schedule to ensure the optimum performance of the CO transmitter. It includes daily and quarterly procedures.

Daily

Verify a display reading of 0 PPM CO at the controller. Investigate significant changes in the display reading.

Quarterly

Calibrate the CO transmitter as described in the Calibration section of this manual.

Troubleshooting

The troubleshooting guide describes symptoms, probable causes, and recommended action for problems you may encounter with the CO transmitter.

NOTE: This troubleshooting guide describes transmitter problems only. See the controller operator's manual for problems you may encounter with the controller.

Fail Condition

Symptoms

- The controller indicates a fail condition.

Probable causes

- The transmitter wiring is disconnected or misconnected.
- The transmitter's zero reading is low enough to cause a fail condition.
- The transmitter is malfunctioning.

Recommended action

- Verify that the transmitter wiring is correct and secure.
- Calibrate the transmitter.
- If the fail condition continues, replace the CO sensor.
- If the fail condition continues, contact RKI for further instruction.

Slow or No Response/Difficult or Unable to Calibrate

Symptoms

- Unable to accurately set the zero or response reading during the calibration procedure.
- The transmitter requires frequent calibration.

NOTE: Under “normal” circumstances, the transmitter requires calibration once every three months. Some applications may require a more frequent calibration schedule.

Probable causes

- The calibration cylinder is low, out-dated, or defective.
- The transmitter is malfunctioning.

Recommended action

1. Verify that the calibration cylinder contains an adequate supply of a fresh test sample.
2. If the calibration/response difficulties continue, replace the CO sensor as described later in this section.
3. If the calibration/response difficulties continue, contact RKI Instruments, Inc., for further instruction.

Replacing Components of the CO Transmitter

This section includes procedure to replace the CO sensor and amplifier. A procedure to replace the entire detector assembly is at the end of this section. In most cases, it is not necessary to replace the entire detector assembly.

Replacing the Sensor

CAUTION: *The sensor contains electrolyte which is a dilute acid. Do not disassemble the sensor when replacing it with a new one. If sensor electrolyte comes in contact with your skin, wash affected area thoroughly with soap and water.*

1. Turn off the controller.
2. Turn off or unplug incoming power to the controller.
3. Unscrew the bottom section of the CO detector housing from the top section.
4. Unplug and remove the CO sensor with the boot and charcoal filter attached.
5. Remove the rubber boot and charcoal filter from old sensor.

6. Remove the replacement sensor from its packaging and remove the wire jumper. This wire jumper is installed on the sensor pins for shipment or storage but must be removed for the sensor to operate properly when installed in a detector.

WARNING: *The CO sensor will not operate properly if the wire jumper is not removed.*

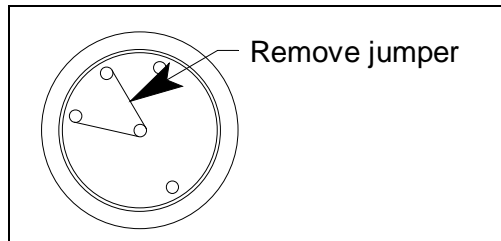

Figure 5: Plug-In Sensor Jumper Removal

7. Install the rubber boot with charcoal filter onto the replacement sensor's face.
8. Carefully plug the replacement sensor into the socket pattern that is located in the top section of the detector housing.

NOTE: Match the sensor's male pins with the four female sockets as you plug the sensor into the socket.

9. Screw the bottom section of the detector housing onto the top section.
10. Turn on or plug in incoming power to the controller.
11. Turn on the controller.

CAUTION: *Allow the replacement sensor to warm up for 5 minutes before you continue with the next step.*

12. Calibrate the replacement sensor as described in the Calibration section of this manual.

Replacing the Charcoal Filter

1. Turn off the controller.
2. Turn off or unplug incoming power at the power source end.
3. Unscrew the bottom section of the CO detector housing from the top section.
4. Unplug and remove the CO sensor with the boot and charcoal filter attached.
5. Remove the rubber boot that secures the charcoal filter to the CO sensor.
6. Remove the charcoal filter from the rubber boot.
7. Place the replacement filter in the rubber boot in the same position as the filter you removed in the previous step.
8. Reinstall the rubber boot with charcoal filter to the CO sensor.

9. Carefully plug the replacement sensor into the socket pattern that is located in the top section of the detector housing.

NOTE: Match the sensor's male pins with the four female sockets as you plug the sensor into the sockets.

10. Screw the bottom section of the detector housing onto the top section.
11. Turn on or plug in incoming power at the power source end.
12. Turn on the controller.

Replacing the Amplifier

1. Turn off the controller.
2. Turn off or unplug incoming power to the controller.
3. Remove the junction box cover.
4. Disconnect the detector leads from the detector terminal strip.
5. Unscrew and remove the two screws that secure the amplifier to the junction box. The screws are at the top left and bottom right of the amplifier.
6. Remove the amplifier.
7. Place the new amplifier in the same position as the old amplifier.
8. Use the two screws you removed in step 5 to secure the new amplifier to the junction box.
9. Verify that the jumper block is installed over the **TOXIC** selector of the amplifier type selector as shown in Figure 3.
10. Reconnect the wiring from the controller to the interconnect terminal strip as shown in Table 2 and Figure 3.

Table 2: Reconnecting the CO Amplifier to a Controller

Amplifier Interconnect Terminal Strip	Controller Transmitter Terminal Strip (typical)
4/20 FB	4 -20 (FB)
24V +	+ V (11 - 30 VDC)

11. Reconnect the detector leads to the detector terminal strip as shown in Table 3 and Figure 3.

Table 3: Reconnecting the CO Detector to the Amplifier

CO Detector Lead	Amplifier Interconnect Terminal Strip
Black	TOXIC BK
Red	TOXIC RD

12. Reinstall the junction box cover.
13. Turn on or plug in incoming power at the power source end.
14. Turn on the controller.

CAUTION: Allow the sensor to warm up for 5 minutes before you continue with the next step.

15. Calibrate the CO transmitter as described in the Calibration section of this manual.

Replacing the CO Detector

NOTE: In most cases, it is only necessary to replace the CO sensor.

1. Turn off the controller.
2. Turn off or unplug incoming power at the power source end.
3. Remove the junction box cover.
4. Disconnect the detector leads from the detector terminal strip. Note the position of the color-coded leads as you remove them.
5. Unscrew the detector from the junction box.
6. Guide the detector leads of the replacement detector through the bottom conduit hub of the junction box, then screw the mounting threads of the detector into the conduit hub.
7. Connect the detector leads to the detector terminal strip as shown in Table 4 and Figure 3.

Table 4: Connecting the Replacement CO Detector to the Amplifier

CO Detector Lead	Amplifier Interconnect Terminal Strip
Black	TOXIC BK
Red	TOXIC RD

8. Reinstall the junction box cover.

9. Turn on or plug in incoming power to the controller.
10. Turn on the controller.

CAUTION: *Allow the replacement detector to warm up for 5 minutes before you continue with the next step.*

11. Calibrate the replacement detector as described in the Calibration section of this manual.
12. Secure the junction box cover to the junction box.

Calibration Frequency

Although there is no particular calibration frequency that is correct for all applications, a calibration frequency of every 3 to 6 months is adequate for most CO transmitter applications. Unless experience in a particular application dictates otherwise, RKI Instruments, Inc. recommends a calibration frequency of every 3 months.

If an application is not very demanding, for example detection in a clean, temperature controlled environment where CO is not normally present and calibration adjustments are minimal at calibration, then a calibration frequency of every 6 months is adequate.

If an application is very demanding, for example if CO is present often and in significant concentrations or the environment is not well controlled, then more frequent calibration than every 3 months may be necessary.

Calibration

This section describes how to calibrate the CO transmitter. It includes procedures to prepare for calibration, set the zero reading, set the response reading, and return to normal operation. It describes the test using a calibration kit that includes a calibration cup, calibration gas, sample tubing, and a fixed flow regulator with an on/off knob. RKI Instruments, Inc. recommends using a 0.5 LPM (liters per minute) fixed flow regulator.

Preparing for Calibration

NOTE: Calibrating the CO transmitter may cause alarms. Be sure to put the controller into its calibration program or disable external alarms before calibrating.

1. Screw the calibration cup onto the bottom of the CO detector.
2. Screw the regulator into the zero air calibration cylinder.
3. Use the sample tubing to connect the fixed flow regulator to the calibration cup.
4. Set a voltmeter to measure in the millivolt (mV) range.

WARNING: Do not remove the sensor cap or junction box cover while the circuits are energized unless the area is determined to be non-hazardous. Keep the sensor cap and junction box cover tightly closed during operation.

5. Remove the junction box cover, then plug the voltmeter leads into the test points on the amplifier.

Plug the positive lead into the test point labeled **TP+**; plug the negative lead into the test point labeled **TP-**.

6. Use the following formula to determine the correct test points output for the calibrating sample.

$$\text{Output (mV)} = (\text{calibrating sample/fullscale}) \times 400 + 100$$

For example, with a calibrating sample of 50 PPM CO and a fullscale setting of 300 PPM, the correct output is 167 mV.

$$167 \text{ (mV)} = (50/300) \times 400 + 100$$

Setting the Zero Reading

NOTE: If you can verify that the CO transmitter is in a fresh air environment, you do not need to apply zero air to the detector before adjusting the zero reading.

1. Turn the regulator on/off knob counterclockwise to open it.
2. Allow the gas to flow for two minutes.
3. Verify a reading of 100 mV (± 2 mV).
4. If necessary, use the zero pot on the amplifier to adjust the reading to 100 mV (± 2 mV).
5. Turn the regulator on/off knob clockwise to close it.
6. Unscrew the regulator from the zero air calibration cylinder.

Leave the sample tubing connected to the regulator and the calibration cup.

Setting the Response Reading

1. Screw the regulator into the calibration cylinder. Verify that the calibration gas is representative of the transmitter's target gas.
2. Turn the regulator on/off knob counterclockwise to open it.
3. Allow the gas to flow for two minutes.
4. Verify that the reading matches the response reading (± 2 mV) you determined earlier.
5. If necessary, use the span pot on the amplifier to adjust the reading to match the correct response reading.
6. Turn the regulator on/off knob clockwise to close it.
7. Unscrew the regulator from the calibration cylinder.

8. Unscrew the calibration cup from the detector.

NOTE: For convenience, leave the components of the calibration kit connected by the sample tubing.

Returning to Normal Operation

1. Remove the voltmeter leads from the amplifier test points.
2. Secure the junction box cover to the junction box.
3. When the display reading falls below the alarm setpoints, return the controller to normal operation.
4. Verify that the controller display reading decreases and stabilizes at 0 ppm.
5. Store the components of the calibration kit in a safe and convenient place.

Parts List

Table 5 lists replacement parts and accessories for the CO transmitter.

Table 5: Parts List

Part Number	Description
06-1248RK	Sample tubing (order by the foot)
07-0033RK	Detector housing cap gasket
07-0203RK	Rubber retaining boot (for charcoal filter)
18-0405RK-01	Junction box (without cover; pre drilled for amplifier)
18-0406RK	Junction box cover
33-7101RK	Charcoal Filter Disk
57-1060RK	Amplifier (specify target gas when ordering)
65-2432RK-05	CO transmitter (includes detector and amplifier), CSA classified
65-2438	CO replacement detector assembly (includes sensor), CSA classified
71-0113RK	<i>65-2432RK-05 CO Transmitter Operator's Manual</i> (this document)
81-0064RK-01	Calibration cylinder, 50 PPM CO in air, 34 liter steel
81-0076RK-01	Zero air calibration cylinder, 34 liter steel
81-1050RK	Regulator with gauge and knob, 0.5 LPM, for 17 liter and 34 liter steel calibration cylinders (cylinders with external threads)
81-1117RK	Calibration cup
ES-1531-CO	CO replacement sensor