

# **65-2507RK Oxygen Transmitter Operator's Manual**

*Part Number: 71-0080RK*

*Revision: B*

*Released: 1/14/14*

## **WARNING**

Read and understand this instruction manual before operating detector. Improper use of the detector could result in bodily harm or death.

Periodic calibration and maintenance of the detector is essential for proper operation and correct readings. Please calibrate and maintain this detector regularly! Frequency of calibration depends upon the type of use you have and the sensor types. Typical calibration frequencies for most applications are between 3 and 6 months, but can be required more often or less often based on your usage.

---

## Product Warranty

RKI Instruments, Inc. warrants gas alarm equipment sold by us to be free from defects in materials, workmanship, and performance for a period of one year from date of shipment from RKI Instruments, Inc. Any parts found defective within that period will be repaired or replaced, at our option, free of charge. This warranty does not apply to those items which by their nature are subject to deterioration or consumption in normal service, and which must be cleaned, repaired, or replaced on a routine basis. Examples of such items are:

- a) Absorbent cartridges
- b) Pump diaphragms and valves
- c) Fuses
- d) Batteries
- e) Filter elements

Warranty is voided by abuse including mechanical damage, alteration, rough handling, or repair procedures not in accordance with the operator's manual. This warranty indicates the full extent of our liability, and we are not responsible for removal or replacement costs, local repair costs, transportation costs, or contingent expenses incurred without our prior approval.

*THIS WARRANTY IS EXPRESSLY IN LIEU OF ANY AND ALL OTHER WARRANTIES AND REPRESENTATIONS, EXPRESSED OR IMPLIED, AND ALL OTHER OBLIGATIONS OR LIABILITIES ON THE PART OF RKI INSTRUMENTS, INC. INCLUDING BUT NOT LIMITED TO, THE WARRANTY OF MERCHANTABILITY OR FITNESS FOR A PARTICULAR PURPOSE. IN NO EVENT SHALL RKI INSTRUMENTS, INC. BE LIABLE FOR INDIRECT, INCIDENTAL, OR CONSEQUENTIAL LOSS OR DAMAGE OF ANY KIND CONNECTED WITH THE USE OF ITS PRODUCTS OR FAILURE OF ITS PRODUCTS TO FUNCTION OR OPERATE PROPERLY.*

This warranty covers instruments and parts sold to users by authorized distributors, dealers, and representatives as appointed by RKI Instruments, Inc.

We do not assume indemnification for any accident or damage caused by the operation of this gas monitor, and our warranty is limited to the replacement of parts or our complete goods.

---

## Table of Contents

|  |           |
|--|-----------|
| <b>Overview</b> .....                                | <b>1</b>  |
| <b>Specifications</b> .....                          | <b>1</b>  |
| <b>Description</b> .....                             | <b>2</b>  |
| Oxygen Detector .....                                | 2         |
| Amplifier .....                                      | 3         |
| Junction Box .....                                   | 4         |
| <b>Installation</b> .....                            | <b>4</b>  |
| Mounting the Oxygen Transmitter .....                | 4         |
| Wiring the Oxygen Transmitter to a Controller .....  | 5         |
| <b>Start Up</b> .....                                | <b>7</b>  |
| Introducing Incoming Power .....                     | 7         |
| Setting the Fresh Air Signal .....                   | 7         |
| <b>Maintenance</b> .....                             | <b>8</b>  |
| Preventive Maintenance .....                         | 8         |
| Troubleshooting .....                                | 9         |
| Replacing Components of the Oxygen Transmitter ..... | 9         |
| <b>Calibration Frequency</b> .....                   | <b>11</b> |
| <b>Calibration</b> .....                             | <b>12</b> |
| Preparing for Calibration .....                      | 12        |
| Setting the Fresh Air Reading .....                  | 12        |
| Setting the Zero Reading .....                       | 12        |
| Returning to Normal Operation .....                  | 13        |
| <b>Parts List</b> .....                              | <b>13</b> |

---

## Overview

This instruction manual describes the oxygen transmitter. This manual also describes how to install, start up, configure, maintain, and calibrate the transmitter when using it with a gas monitoring controller. A parts list at the end of this manual lists replacement parts and accessories for the oxygen transmitter. See the operator's manual for the controller for information specific to the controller.

---

## Specifications

Table 1 lists specifications for the oxygen transmitter.

**Table 1: Specifications**

| Description     | Specification              |
|-----------------|----------------------------|
| Target Gas      | Oxygen (O <sub>2</sub> )   |
| Sampling Method | Diffusion                  |
| Signal Output   | 4 - 20 mA                  |
| Detection Range | 0 to 25.0% VOL (by volume) |
| Accuracy        | ± 0.5% O <sub>2</sub>      |
| Response Time   | 90% in 30 seconds          |

---

**WARNING:** *When using the 65-2507RK, you must follow the instructions and warnings in this manual to assure proper and safe operation of the 65-2507RK and to minimize the risk of personal injury. Be sure to maintain and periodically calibrate the 65-2507RK as described in this manual.*

---

## Description

This section describes the components of the oxygen transmitter. The transmitter consists of the oxygen detector, amplifier, and junction box.

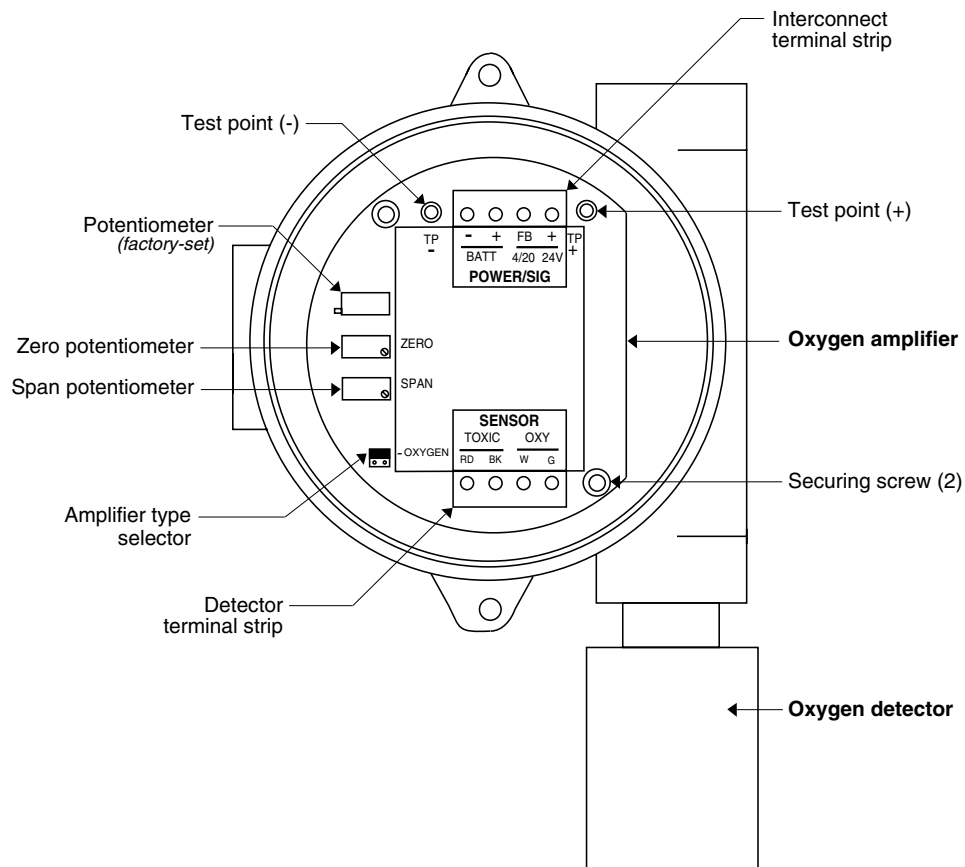

Figure 1: Oxygen Transmitter Component Location

### Oxygen Detector

The oxygen detector includes the oxygen sensor, detector housing, and detector leads.

#### Oxygen Sensor

The oxygen sensor is encapsulated within the detector housing. Through a series of chemical and electronic reactions, the sensor produces an electrical output that is proportional to the detection range of the transmitter. The oxygen sensor used is a capillary type that is not susceptible to output changes with changes in atmospheric pressure.

#### Detector Housing

The oxygen sensor is encapsulated within the detector housing. Mounting threads (3/4 in. NPT) at the top of the detector housing allow you to mount the oxygen detector into the bottom conduit hub of the junction box.

#### Detector Leads

Two color-coded leads extend from the top of the detector. The leads allow you to connect the oxygen detector to the amplifier.

## **Amplifier**

The amplifier converts the electrical output from the oxygen detector to a 4 - 20 mA signal that is proportional to the detection range and transmits the signal to the controller. The amplifier includes the amplifier type selector, detector terminal strip, interconnect terminal strip, span pot, zero pot, and test points (see Figure 1).

### ***Amplifier Type Selector***

The amplifier type selector is near the bottom left corner of the amplifier. It is below the span pot and to the left of the detector terminal strip.

The amplifier included with the oxygen transmitter is designed for use with RKI's oxygen and toxic gas transmitters. The amplifier type selector determines for which transmitter the amplifier is intended. For oxygen transmitters, a jumper block is installed over the **OXYGEN** selector (see Figure 1).

### ***Detector Terminal Strip***

The detector terminal strip is the four-point terminal strip near the bottom of the amplifier. Use the detector terminal strip to connect the oxygen detector to the amplifier.

---

**NOTE:** The oxygen detector is factory-wired to the amplifier. See the Installation section of this manual for all wiring procedures related to the transmitter.

---

### ***Interconnect Terminal Strip***

The interconnect terminal strip is the four-point terminal strip near the top of the amplifier. Use the interconnect terminal strip to connect the amplifier to the controller.

### ***Span Pot***

The span pot is on the left side of the amplifier. Of the three pots, the span pot is closest to the bottom of the amplifier. Use the span pot to adjust the transmitter's response output during the start-up and calibration procedures.

### ***Zero Pot***

The zero pot is directly above the span pot. Use the zero pot to adjust the transmitter's oxygen-free output during the start-up and calibration procedure.

---

**CAUTION:** *The amplifier includes an additional potentiometer above the zero potentiometer. It is factory-set. Do not adjust it.*

---

### ***Test Points***

The test points (labeled **TP-** and **TP+**) are directly to the left and right of the interconnect terminal strip. The test points produce a 100 - 500 mV output that is proportional to the transmitter's 4 - 20 mA output. Use the test points and a voltmeter to measure the transmitter's output during the start-up and calibration procedures.

## Junction Box

Use the junction box to install the oxygen transmitter at a mounting site that is remote from the controller. The junction box also protects the amplifier and wiring connections made to the amplifier. Use the two 3/4 in. conduit hubs to mount the detector to the junction box (bottom hub) and connect wiring from the amplifier to the controller (top hub).

---

**NOTE:** The oxygen detector and amplifier are factory-mounted to the junction box.

---

Use the junction box's two mounting holes to mount the oxygen transmitter to a vertical surface at the monitoring site. Use the cover on the front of the junction box to access the interior of the junction box.

---

## Installation

This section describes procedures to mount the oxygen transmitter in the monitoring environment and wire the transmitter to a controller.

### Mounting the Oxygen Transmitter

1. Select a mounting site that is representative of the monitoring environment. Consider the following when you select the mounting site.
  - Select a site where the transmitter is not likely to be bumped or disturbed. Make sure there is sufficient room to perform start-up, maintenance, and calibration procedures.
  - Select a site that is at normal breathing level.

---

**CAUTION:** *Mount the oxygen transmitter with the detector facing down (see Figure 2).*

---



2. At the monitoring site, use #10 screws through the junction box's two mounting holes to secure the junction box to a vertical surface (see Figure 2).

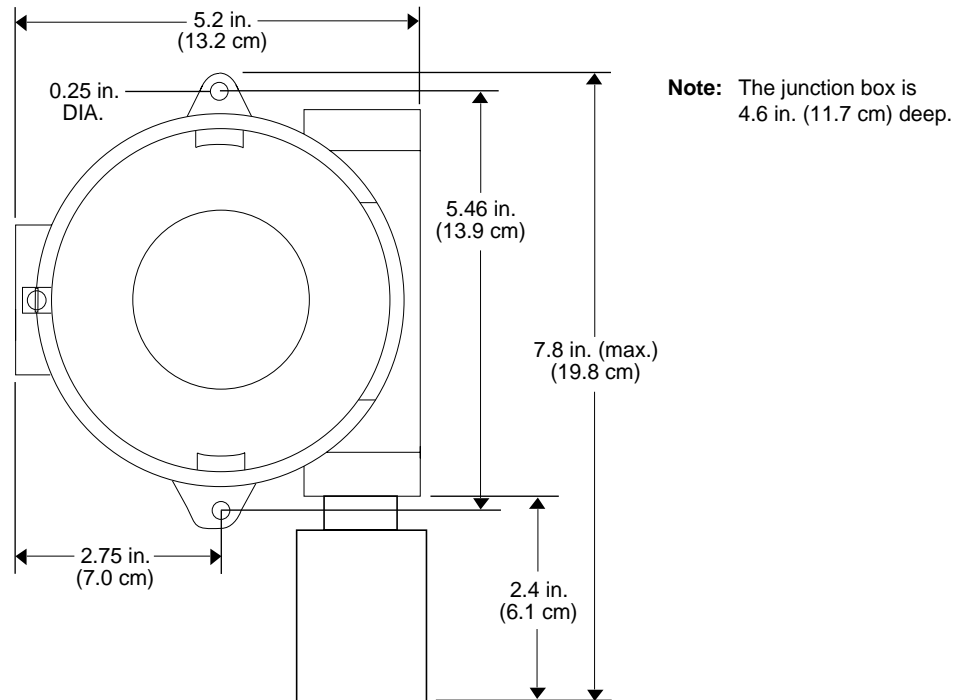

Figure 2: Mounting the Oxygen Transmitter

## Wiring the Oxygen Transmitter to a Controller

---

**WARNING:** Always verify that the controller is off and power to the controller is off before you make wiring connections.

---

1. Turn off the controller.
2. Turn off power to the controller.
3. Remove the junction box cover.
4. Verify that the detector leads are wired to the amplifier's detector terminal strip. If necessary, connect the leads to the detector terminal strip as shown in Figure 3.
5. Verify that the jumper block is installed over the **OXYGEN** selector of the amplifier type selector as shown in Figure 3.
6. Install an appropriate cable bushing or conduit fitting on the top conduit hub of the junction box.
7. Guide a two-conductor, shielded cable or two wires in conduit through the top conduit hub of the junction box.
8. Connect the two wires to the interconnect terminal strip as follows (see Figure 3).
  - Connect the positive wire to the terminal labeled **24V +**.
  - Connect the feedback wire to the terminal labeled **4/20 FB**.

---

**CAUTION:** Leave the cable drain (shield) wire insulated and disconnected at the transmitter. You will connect the opposite end of the cable's drain wire at the controller.

---

- Secure the junction box cover to the junction box.
- Route the cable or wires leading from the oxygen transmitter through one of the conduit hubs at the controller.

---

**CAUTION:** Do not route power and transmitter wiring through the same conduit hub. The power cable may disrupt the transmission of the transmitter signal to the controller.

---

- Connect the wires to the applicable transmitter terminal strip at the controller as shown in Figure 3.

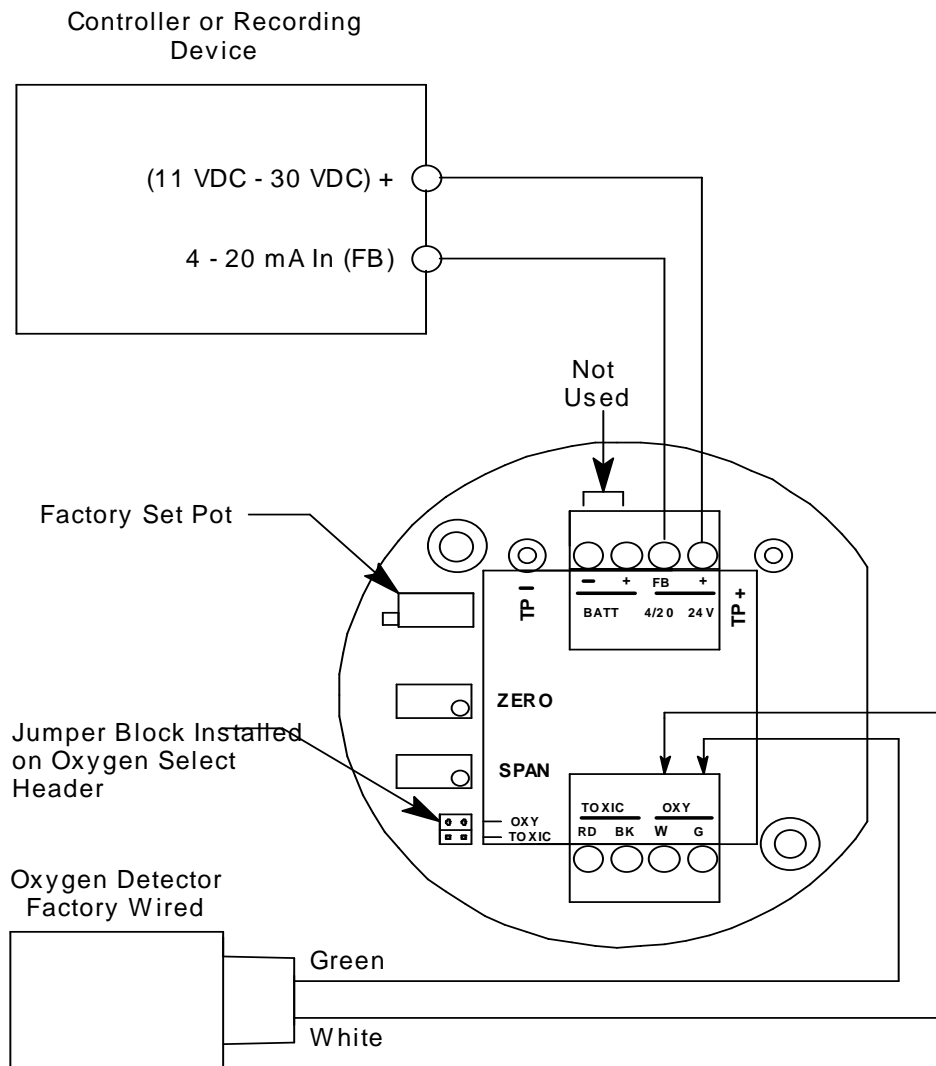

**Figure 3: Wiring the Oxygen Transmitter to a Controller**

- If using shielded cable, connect the cable's drain wire to an available chassis ground at the controller. RKI controllers typically have a ground stud that is a convenient grounding location.

---

## Start Up

This section describes procedures to start up the oxygen transmitter and place the transmitter into normal operation with a controller.

### Introducing Incoming Power

1. Complete the installation procedures described earlier in this manual.
2. Verify that the power wiring is correct and secure. Refer to the controller operator's manual for connections at the controller.
3. Turn on or plug in the incoming power to the controller, then turn on the controller.
4. Verify that the controller is on and operating properly. Refer to the controller operator's manual.

---

**CAUTION:** *Allow the detector to warm up for 5 minutes before you continue with the next section, "Setting the Fresh Air Signal".*

---

### Setting the Fresh Air Signal

---

**NOTE:** If you can verify that the detector is in a fresh air environment (environment known to be of normal oxygen content and free of toxic and combustible gases), it is not necessary to apply zero air when verifying or setting the fresh air reading.

---

The procedure below describes applying zero emission air, usually called zero air, using a calibration kit that includes a calibration cup, calibration gas, sample tubing, and a fixed flow regulator with an on/off knob. RKI Instruments, Inc. recommends using a 0.5 LPM (liters per minute) fixed flow regulator.

1. Unscrew and remove the junction box cover from the junction box.
2. Set a voltmeter to measure in the millivolt (mV) range.
3. Plug the voltmeter leads into the test points on the amplifier. Plug the positive lead into the test point labeled **TP+**; plug the negative lead into the test point labeled **TP-**.
4. Slide the calibration cup over the bottom of the oxygen detector, then secure the calibration cup to the detector with the thumb screw.
5. Screw the regulator onto the zero air calibration cylinder.
6. Use the sample tubing to connect the regulator to the calibration cup.
7. Turn the regulator's on/off knob counterclockwise to open it. Gas will begin to flow.
8. Allow the gas to flow for 2 minutes.
9. Verify a voltmeter reading of 434 mV ( $\pm 2$  mV).
10. If necessary, use a flat-blade screwdriver to adjust the span pot until the voltmeter reading is 434 mV ( $\pm 2$  mV).
11. Turn the regulator's on/off knob clockwise to close it.
12. Remove the calibration cup from the detector.
13. Unscrew the regulator from the zero air calibration cylinder. For convenience, leave the sample tubing connected to the regulator and the calibration cup.
14. Store the components of the calibration kit in a safe and convenient place.

15. Remove the voltmeter leads from the test points.
16. Secure the junction box cover to the junction box.

---

## Maintenance

This section describes maintenance procedures. It includes preventive maintenance, troubleshooting, and component replacement procedures.

### Preventive Maintenance

This section describes a preventive maintenance schedule to ensure the optimum performance of the oxygen transmitter. It includes daily, monthly, and quarterly procedures.

#### *Daily*

Verify a display reading of 20.9% oxygen at the controller. Investigate significant changes in the reading.

#### *Monthly*

This procedure describes a test to verify that the oxygen transmitter responds properly to oxygen deficiency.

---

**NOTE:** Performing a response test on the oxygen transmitter may cause alarms. Be sure to put the controller into its calibration program or disable external alarms before performing this test.

---

#### *Preparing for the response test*

1. Verify that the display reading for the channel you are testing is 20.9% oxygen.  
If the display reading is not 20.9% oxygen, set the fresh air reading of the transmitter as described in “Start Up” on page 7 of this manual, then continue this procedure.
2. Set a voltmeter to measure in the millivolt (mV) range.
3. Remove the junction box cover, then plug the voltmeter leads into the test points on the amplifier. Plug the positive lead into the test point labeled **TP+**; plug the negative lead into the test point labeled **TP-**.

#### *Performing the response test*

1. Exhale into the bottom of the oxygen detector housing.
2. Stop exhaling into the bottom of the detector, then verify that the readings on the voltmeter decreased from the normal reading (434 mV).

---

**NOTE:** If the reading does not decrease, calibrate the affected transmitter as described in “Calibration” on page 12 of this manual.

---

3. Remove the voltmeter leads from the amplifier test points, then secure the junction box cover to the junction box.
4. When the display reading rises above the decreasing alarm setpoint, return the controller to normal operation.

#### *Quarterly*

Calibrate the oxygen transmitter as described in “Calibration” on page 12 of this manual.

## Troubleshooting

The troubleshooting guide describes symptoms, probable causes, and recommended action for problems you may encounter with the oxygen transmitter.

---

**NOTE:** This troubleshooting guide describes transmitter problems only. See the controller operator's manual for problems you may encounter with the controller.

---

**Table 2: Troubleshooting the Oxygen Transmitter**

| Condition  | Symptom(s)  | Probable Causes   | Recommended Action   |
|--|---|---|--|
| Fail Condition   | <ul style="list-style-type: none"> <li>Controller indicates a fail condition.</li> </ul>  | <ul style="list-style-type: none"> <li>The transmitter wiring is disconnected or misconnected.</li> <li>The transmitter is malfunctioning.</li> </ul>   | <ol style="list-style-type: none"> <li>Verify that the transmitter wiring is correct and secure.</li> <li>Calibrate the transmitter.</li> <li>If the fail condition continues, replace the oxygen sensor.</li> <li>If the fail condition continues, contact RKI for further instruction.</li> </ol>                                |
| Slow or No Response/<br>Difficult or Unable to Calibrate | <ul style="list-style-type: none"> <li>Transmitter responds slowly or does not respond to response test.</li> <li>Unable to accurately set the fresh air or zero reading during calibration.</li> <li>Transmitter requires frequent calibration.</li> </ul> <p><i>Note: Under "normal" circumstances, the transmitter requires calibration once every three months. Some applications may require a more frequent calibration schedule.</i></p> | <ul style="list-style-type: none"> <li>The calibration cylinder is low, out-dated, or defective.</li> <li>The transmitter is malfunctioning.</li> </ul> | <ol style="list-style-type: none"> <li>Verify that the calibration cylinder contains an adequate supply of a fresh test sample.</li> <li>If the calibration/response difficulties continue, replace the oxygen sensor.</li> <li>If the calibration/response difficulties continue, contact RKI for further instruction.</li> </ol> |

## Replacing Components of the Oxygen Transmitter

This section includes procedures to replace the oxygen detector and amplifier.

### ***Replacing the Oxygen Detector***

- Turn off the controller.
- Turn off power to the controller.
- Remove the junction box cover.
- Disconnect the detector leads from the detector terminal strip. Note the position of the color-coded leads as you remove them.
- Unscrew the detector from the junction box.
- Guide the detector leads of the replacement detector through the bottom conduit hub of the junction box, then screw the mounting threads of the detector into the conduit hub.

7. Connect the detector leads to the amplifier's detector terminal strip as shown in Table 3 below and Figure 3 on page 6 of this manual.

**Table 3: Reconnecting the Oxygen Detector to the Amplifier**

| Detector Lead | Detector Terminal Strip |
|---------------|-------------------------|
| White         | OXY W                   |
| Green         | OXY G                   |

8. Turn on power to the controller.
9. Turn on the controller.
10. Calibrate the replacement detector as described in "Calibration" on page 12 of this manual.

***Replacing the Amplifier***

1. Turn off the controller.
2. Turn off power to the controller.
3. Remove the junction box cover.
4. Disconnect the detector leads from the detector terminal strip.
5. Disconnect the wiring that connects the oxygen transmitter to the controller from the amplifier's interconnect terminal strip.
6. Unscrew and remove the two screws that secure the amplifier to the junction box. The screws are at the top left and bottom right of the amplifier.
7. Remove the amplifier.
8. Place the new amplifier in the same position as the amplifier you removed in the previous step.
9. Use the two screws you removed in step 5 to secure the amplifier to the junction box.
10. Reconnect the wiring that connects the controller and oxygen transmitter to the amplifier's interconnect terminal strip as shown in Table 4 below and Figure 3 on page 6 of this manual.

**Table 4: Reconnecting the Oxygen Amplifier to the Controller**

| Amplifier Interconnect Terminal Strip | Controller Transmitter Terminal Strip |
|---------------------------------------|---------------------------------------|
| 4/20                                  | 4 - 20 (FB)                           |
| 24V                                   | + (11 VDC - 30VDC)                    |

11. Reconnect the detector leads to the amplifier's detector terminal strip as shown in Table 5 below and Figure 3 on page 6 of this manual.

**Table 5: Reconnecting the Oxygen Detector to the Amplifier**

| Detector Lead | Detector Terminal Strip |
|---------------|-------------------------|
| White         | OXY W                   |
| Green         | OXY G                   |

12. Turn of power to the controller.
13. Turn on the controller.
14. Calibrate the oxygen transmitter as described in "Calibration" on page 12 of this manual.

---

## Calibration Frequency

Although there is no particular calibration frequency that is correct for all applications, a calibration frequency of every 3 months is adequate for most oxygen transmitter applications. Unless experience in a particular application dictates otherwise, RKI Instruments, Inc. recommends a calibration frequency of every 3 months for the oxygen transmitter.

If an application is not very demanding, for example detection in a clean, temperature controlled environment, and calibration adjustments are minimal at calibration, then a calibration frequency of every 6 months is adequate.

If the application is very demanding, for example if the environment is not well controlled, then more frequent calibration than every 3 months may be necessary.

---

## Calibration

This section describes how to calibrate the oxygen transmitter. It includes procedures to prepare for calibration, set the fresh air reading, set the zero reading, and return to normal operation. It describes the test using a calibration kit that includes a calibration cup, calibration gas, sample tubing, and a fixed flow regulator with an on/off knob. RKI Instruments, Inc. recommends using a 0.5 LPM (liters per minute) fixed flow regulator.

---

**NOTE:** Calibrating the oxygen transmitter may cause alarms. Be sure to put the controller into its calibration program or disable external alarms before continuing.

---

### Preparing for Calibration

1. Unscrew and remove the junction box cover.
2. Set a voltmeter to measure in the millivolt (mV) range.
3. Plug the positive lead into the test point labeled **TP+**; plug the negative lead into the test point labeled **TP-**.
4. Slide the calibration cup over the bottom of the oxygen detector, then secure the calibration cup to the detector with the thumb screw.

### Setting the Fresh Air Reading

---

**NOTE:** If you can verify that the oxygen transmitter is in a fresh air environment, you do not need to apply zero air to the detector before adjusting the zero reading.

---

1. Screw the regulator into the zero air calibration cylinder.
2. Use the sample tubing to connect the regulator to the calibration cup.
3. Turn the regulator knob counterclockwise to open the regulator.
4. Allow the gas to flow for 2 minutes.
5. Verify a voltmeter reading of 434 mV ( $\pm 2$  mV).
6. If necessary, use a flat-blade screwdriver to adjust the span pot on the amplifier until the voltmeter reading is 434 mV ( $\pm 2$  mV).
7. Turn the regulator knob clockwise to close the regulator.
8. Unscrew the regulator from the zero air calibration cylinder.
9. Leave the sample tubing connected to the regulator and the calibration cup.

---

**NOTE:** Depending on the size of your zero air cylinder, it is possible that you will have a different regulator for the zero air cylinder and the 100% nitrogen cylinder. If necessary to fit the nitrogen cylinder, change the regulator.

---

### Setting the Zero Reading

1. Screw the regulator into the 100% nitrogen calibration cylinder.
2. Turn the regulator knob counterclockwise to open the regulator.
3. Allow the gas to flow for two minutes and verify a reading of 100 mV ( $\pm 2$  mV).



4. If necessary, use the zero pot on the amplifier to adjust the reading to 100 mV ( $\pm 2$  mV).
5. Turn the regulator knob clockwise to close the regulator.
6. Remove the regulator from the calibration cylinder.
7. Unscrew the calibration cup from the oxygen detector.

---

**NOTE:** For convenience, leave the components of the calibration kit connected by the sample tubing.

---

### Returning to Normal Operation

1. Remove the voltmeter leads from the amplifier test points.
2. Secure the junction box cover to the junction box.
3. When the display reading rises above the decreasing alarm setpoint, return the controller to normal operation.

---

**NOTE:** If the oxygen reading is below the decreasing alarm setpoint when you return to normal operation, the controller will initiate the appropriate alarm condition.

---

4. Verify that the display reading increases and stabilizes at 20.9% volume.
5. Store the components of the calibration kit in a safe and convenient place.

---

## Parts List

Table 6 lists replacement parts and accessories for the oxygen transmitter.

**Table 6: Parts List**

| Part Number  | Description   |
|--------------|---|
| 06-1248RK    | Sample tubing (3/16 in. x 5/16 in.; specify length when ordering)                             |
| 18-0405RK-01 | Junction box (does not include lid)   |
| 18-0406RK    | Junction box lid  |
| 57-1061RK    | Amplifier (specify target gas when ordering)  |
| 65-2506RK    | Oxygen detector, capillary type, conduit-mounting   |
| 65-2507RK    | Oxygen transmitter (includes detector and amplifier)  |
| 71-0080RK    | <i>65-2507RK Oxygen Transmitter Operator's Manual</i> (this document)                         |
| 81-0076RK-01 | Zero air calibration cylinder (34 liter)  |
| 81-0078RK    | Calibration cylinder (100% nitrogen, 17-liter)  |
| 81-0078RK-01 | Calibration cylinder (100% nitrogen, 34-liter)  |
| 81-1050RK    | Regulator with gauge and knob, 0.5 LPM, for 17 liter and 34 liter steel calibration cylinders |
| 81-1111RK    | Calibration cup   |