

# **Model GD-K7D2 (115 VAC) Sample Draw Detector Operator's Manual**

*Part Number: 71-0077RK*

*Revision: A*

*Released: 3/1/11*

## **WARNING**

Read and understand this instruction manual before operating detector. Improper use of the detector could result in bodily harm or death.

Periodic calibration and maintenance of the detector is essential for proper operation and correct readings. Please calibrate and maintain this detector regularly! Frequency of calibration depends upon the type of use you have and the sensor types. Typical calibration frequencies for most applications are between 3 and 6 months, but can be required more often or less often based on your usage.

# Product Warranty

RKI Instruments, Inc. warrants gas alarm equipment sold by us to be free from defects in materials, workmanship, and performance for a period of one year\* from the date of shipment from RKI Instruments, Inc. Any parts found defective within that period will be repaired or replaced, at our option, free of charge. Parts must be returned to RKI Instruments, Inc. for repair or replacement. This warranty does not apply to those items which by their nature are subject to deterioration or consumption in normal service, and which must be cleaned, repaired or replaced on a routine basis. Examples of such items are:

- |                               |                    |
|-------------------------------|--------------------|
| a) Pump diaphragms and valves | c) Batteries       |
| b) Fuses                      | d) Filter elements |

Warranty is voided by abuse including mechanical damage, alteration, rough handling, or repair procedures not in accordance with instruction manual. This warranty indicates the full extent of our liability, and we are not responsible for removal or replacement costs, local repair costs, transportation costs, or contingent expenses incurred without our prior approval.

*THIS WARRANTY IS EXPRESSLY IN LIEU OF ANY AND ALL OTHER WARRANTIES AND REPRESENTATIONS, EXPRESSED OR IMPLIED, AND ALL OTHER OBLIGATIONS OR LIABILITIES ON THE PART OF RKI INSTRUMENTS, INC. INCLUDING BUT NOT LIMITED TO, THE WARRANTY OF MERCHANTABILITY OR FITNESS FOR A PARTICULAR PURPOSE. IN NO EVENT SHALL RKI INSTRUMENTS, INC. BE LIABLE FOR INDIRECT, INCIDENTAL OR CONSEQUENTIAL LOSS OR DAMAGE OF ANY KIND CONNECTED WITH THE USE OF ITS PRODUCTS OR FAILURE OF ITS PRODUCTS TO FUNCTION OR OPERATE PROPERLY.*

This warranty covers instruments and parts sold to users only by authorized distributors, dealers and representatives as appointed by RKI Instruments, Inc.

We do not assume indemnification for any accident or damage caused by the operation of this gas monitor and our warranty is limited to the replacement of parts or our complete goods. Warranty covers parts and labor performed at RKI Instruments, Inc. only, and does not cover field labor or shipment of parts back to RKI.

---

## Table of Contents

<b>Overview</b> .....	<b>1</b>
<b>Specifications</b> .....	<b>1</b>
<b>Description</b> .....	<b>2</b>
Cover .....	2
Detection Unit .....	3
Installation Bracket .....	5
<b>Installation</b> .....	<b>7</b>
Disassembling the GD-K7D2 .....	7
Mounting the GD-K7D2 .....	7
Connecting Sample Lines to the GD-K7D2 .....	8
Wiring the GD-K7D2 to a Controller .....	10
Assembling the GD-K7D2 .....	12
<b>Startup</b> .....	<b>12</b>
Introducing Incoming Power .....	12
Setting the Zero Signal .....	12
<b>Operation</b> .....	<b>13</b>
Normal Operation .....	13
Low Flow Alarm .....	13
<b>Maintenance</b> .....	<b>14</b>
Preventive Maintenance .....	14
Troubleshooting .....	15
Storing the GD-K7D2 .....	17
Replacing Components of the GD-K7D2 .....	17
<b>Calibration</b> .....	<b>20</b>
Preparing for Calibration .....	20
Setting the Zero Reading .....	20
Setting the Response Reading .....	21
<b>Parts List</b> .....	<b>22</b>

---

## Overview

This manual describes the 115 VAC version of the Model GD-K7D2 sample draw 4 - 20 mA transmitter detector head. This manual also describes how to install, start up, maintain, and calibrate the GD-K7D2 when it is used with a gas monitoring controller. A parts list at the end of this manual lists replacement parts and accessories for the GD-K7D2.

---

## Specifications

Table 1 lists specifications for the 115 VAC version of the GD-K7D2.

**Table 1: Specifications**

Target Gas & Detector Range	Refer to the RKI Instruments Inc. List of Detectable Gasses
Area Classification	Indoor, non-hazardous locations
Sampling Method	Sample-draw
Input Power	<ul style="list-style-type: none"><li>• 115 VAC (for pump)</li><li>• 24 VDC (for detection circuitry)</li></ul>
Signal Output	4 to 20 mA
Response Time	90% in 60 seconds
Accuracy	± 10% of reading or ± 5% of full scale (whichever is greater)
Flow Rate	Approximately 0.5 liters/minute
Recommended Sample Tubing	4 mm I.D. x 6 mm O.D. Teflon PTFE
Recommended Sample Tubing Length	See Table 2 in the Installation section on p. 10

---

**WARNING:** *When using the GD-K7D2, you must follow the instructions and warnings in this manual to assure proper and safe operation of the GD-K7D2 and to minimize the risk of personal injury. Be sure to maintain and periodically calibrate the GD-K7D2 as described in this manual.*

---

---

## Description

This section describes the components of the GD-K7D2. The GD-K7D2 consists of three separate sections: the cover, the detection unit, and the installation bracket. The detection unit (front section) includes the flow system and gas detection components. The L-shaped installation bracket (rear section) includes installation components including a terminal strip, tube fittings and a card edge connector socket.

The detection unit and installation bracket are secured together by a captive screw located in the bottom right of the detection unit. The detection unit's main circuit board plugs into the socket on the installation bracket. The socket is above the terminal strip.

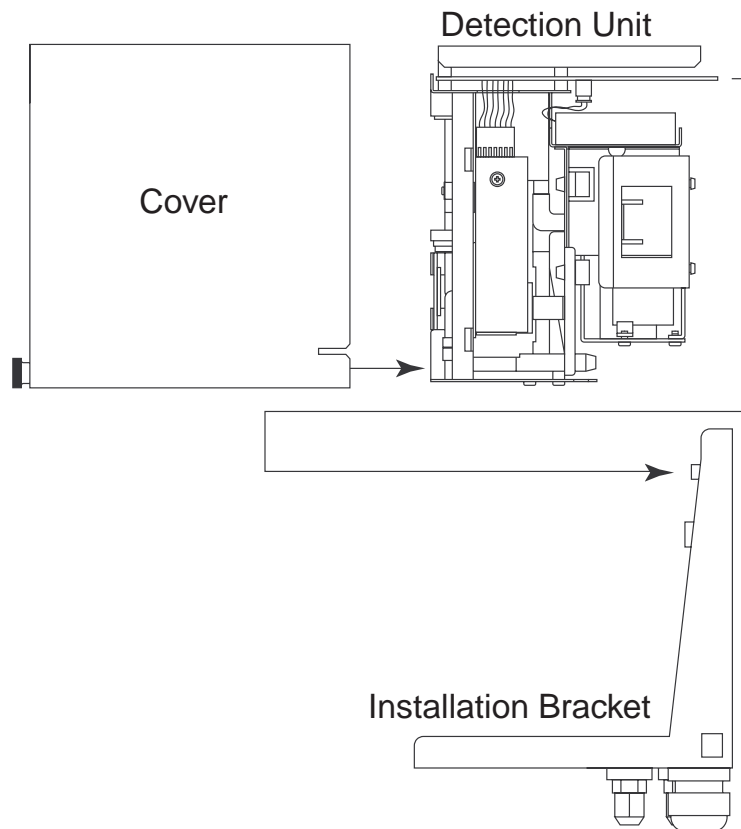

**Figure 1: Sections of the GD-K7D2**

A hydrophobic sample filter is also provided with the GD-K7D2 for installation near the sample in fitting. The filter scrubs particulates out of the sample stream and keeps water and many other liquids from entering the GD-K7D2 flow system.

### Cover

The painted steel cover slides over both the detection unit and installation bracket. It is radio frequency (RF)- and dust-resistant. A thumbscrew on the front of the cover near the bottom secures the cover to the installation bracket (see Figure 1). The cover includes a label on the front that indicates the target gas and detection range of the GD-K7D2.

The flow light and flowmeter are visible through the cover. The flow rate potentiometer (pot) is accessible through cover.

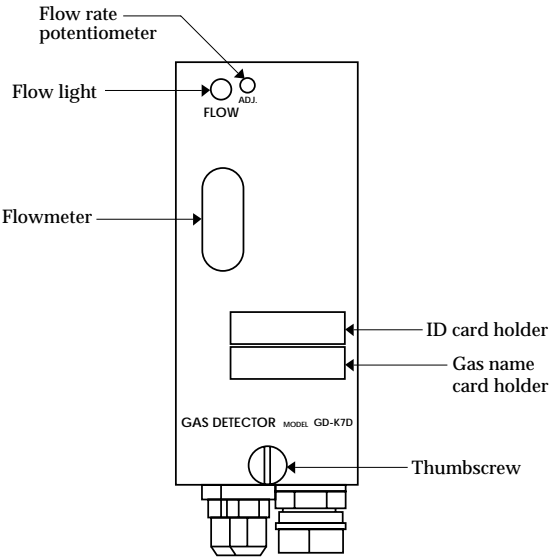

**Figure 2: GD-K7D2 Cover Components**

**Detection Unit**

The detection unit includes the main circuit board, flowmeter, gas sensor, amplifier, pump, and lithium battery pack.

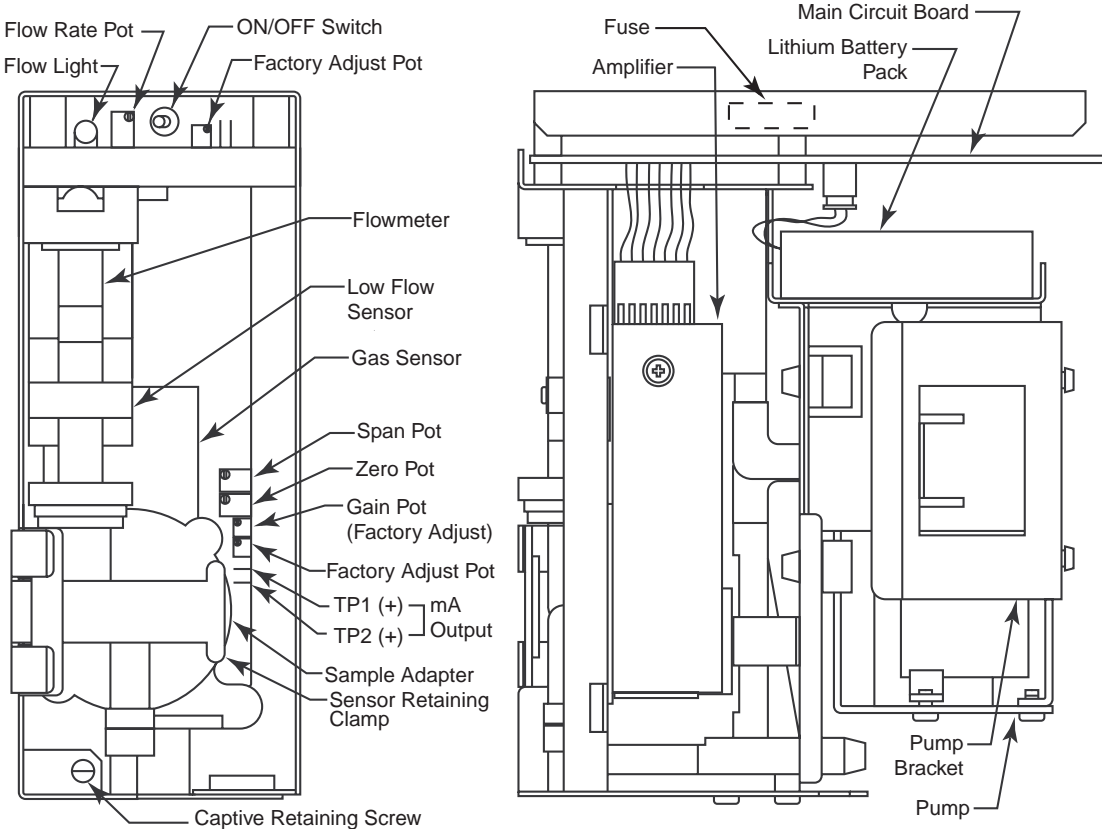

**Figure 3: Detection Unit Component Location**

### **Main Circuit Board**

The main circuit board includes the flow light, flow rate pot, ON/OFF switch and fuse. The end of the board at the rear of the detection unit plugs into a socket on the installation bracket.

#### Flow light

The flow light is at the top left corner of the detection unit (see Figure 2 and 3). The green flow light is on when the GD-K7D2's flow rate is at an acceptable flow rate. If the flow rate drops below or rises above the acceptable flow rate, the flow light turns off.

#### Flow rate pot

The flow rate pot is to the right of the flow light (see Figure 2 and 3). You can adjust the GD-K7D2's flow rate with the flow rate pot. The pot is accessible through a hole in the cover.

#### ON/OFF switch

The ON/OFF switch is to the right of the flow rate pot (see Figure 3). The ON/OFF switch turns the GD-K7D2 on and off. The switch is in the ON position when the toggle switch is in the right position.

#### Fuse

A 2 amp, 5 mm x 20 mm fuse is located on the middle left of the main board. It is accessible by removing four screws that retain a metal cover over the main board.

### **Flowmeter**

The flowmeter is below the flow light (see Figure 2 and 3). A ball in the flowmeter column indicates the flow rate of the GD-K7D2. Two horizontal lines on the flowmeter mark the acceptable flow rate for the GD-K7D2. Use the flow rate pot to keep the flowmeter ball between the two lines. A flow sensor at the bottom of the flowmeter senses when the flowmeter ball is low enough to be at the bottom of the flowmeter and initiates a low flow alarm.

### **Gas Sensor**

The gas sensor is below and to the right of the flowmeter (see Figure 3). Through a series of electrical and chemical reactions, the gas sensor produces an electrical current that is proportional to the detection range of the target gas in the test sample. Electrodes within the gas sensor housing are surrounded by liquid electrolyte. The chemical and electrical reactions are facilitated by the electrolyte.

A sample adapter is attached to the front of the sensor. It directs the sample over a gas permeable membrane on the front of the sensor and into the sensor.

### **Amplifier**

The amplifier is to the right of the sensor (see Figure 3). The amplifier converts the output of the sensor to a 4 to 20 mA signal (that is proportional to the detection range of the GD-K7D2) and transmits the signal to a controller. The amplifier includes the span pot, zero pot, gain pot, and output check pins.

#### Span pot

The span pot is at the top of the amplifier. Use the span pot to adjust the GD-K7D2's response output during the calibration procedure.

#### Zero pot

The zero pot is below the span pot. Use the zero pot to adjust the GD-K7D2's fresh air



output during start-up and calibration procedures.

#### Gain pot

The gain pot is below the zero pot. It is used to make coarse span adjustments. **The gain pot is factory set and for adjustment by a field service technician only.**

Another factory adjust pot is located below the gain pot. Do not adjust this pot.

#### Output check pins

Two output check pins [marked **1 (+)** and **2 (-)**] are below the pots. Use the output check pins to read the signal output of the GD-K7D2 with a milliammeter during the start-up and calibration procedures.

#### **Pump**

The pump is behind the sensor. The pump pulls the test sample into the GD-K7D2. The pump operates on 115 VAC.

#### **Lithium Battery Pack**

A 3.6 volt lithium battery pack is above the pump on the right side of the GD-K7D2. The lithium battery pack maintains a bias voltage on the gas sensor when the GD-K7D2 is not receiving incoming power, such as during shipment or storage. If the GD-K7D2 is off power for an extended period and the lithium battery pack is dead, the gas sensor operation will be affected when the GD-K7D2 is started up. See Storing the GD-K7D2 in the Maintenance section for battery pack replacement recommendations.

### **Installation Bracket**

The L-shaped installation bracket facilitates mounting and wiring of the GD-K7D2. The three mounting holes on the back of the bracket are used to mount it to a vertical surface. The installation bracket includes the socket, external wiring terminal strip, cable bushing, and sample fittings.

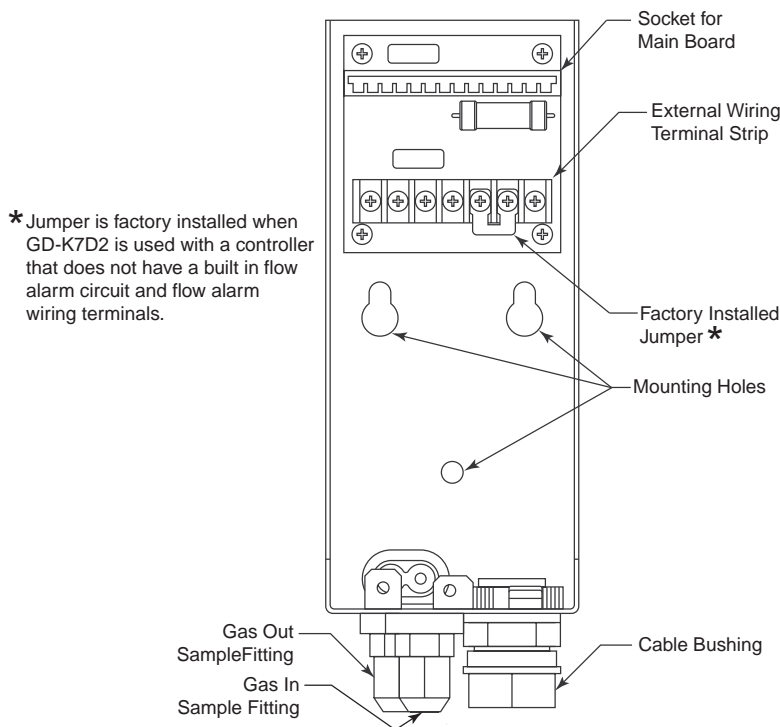

**Figure 4: Installation Bracket Component Location**

**Socket**

A card edge connector socket on the back of the bracket mates with the main circuit board on the detection unit.

**External Wiring Terminal Strip**

A seven point terminal strip is located below the socket and used for wiring the GD-K7D2 to a controller and a 115 VAC power source.

A jumper is normally factory installed between the second and third terminals from the right. This jumper is installed when the GD-K7D2 is used with a controller that does not have a flow alarm circuit and flow alarm terminals for wiring to the GD-K7D2. It is not installed when the GD-K7D2 is used with a controller that has flow alarm circuitry and flow alarm terminals. See *Wiring the GD-K7D2 to a Controller* in the Installation section for both types of wiring.

**Cable Bushing**

The 1/2 in. (1.25 cm) cable bushing on the bottom of the bracket allows you to route wiring from a controller and a 115 VAC power source to the seven point external wiring terminal strip on the back of the bracket.

**Gas In & Gas Out Sample Fittings**

There are two tube fittings on the bottom of the bracket, the gas in and gas out sample fittings. The gas in fitting is forward of the gas out fitting. The gas in fitting allows sample to enter the GD-K7D2 and the gas out fitting is for exhausting the sample. Both fittings accept 6 mm O.D. x 4 mm I.D. Teflon PTFE tubing.

## Installation

This section describes how to install the GD-K7D2 at the monitoring site. This section includes procedures to disassemble the GD-K7D2, mount the GD-K7D2, connect sample lines to the GD-K7D2, and wire the GD-K7D2 to a controller.

### Disassembling the GD-K7D2

1. Loosen the thumbscrew on the front of the housing cover, then remove the cover from the detection unit and installation bracket.
2. Loosen the captive screw in the lower left front of the detection unit that secures it to the installation bracket.
3. Pull the detection unit away from the installation bracket until the main board disengages from the socket, then lift it up slightly to free the detection unit from the installation bracket.

### Mounting the GD-K7D2

---

**CAUTION:** *The GD-K7D2 is suitable for installation in indoor areas where general purpose equipment is in use.*

---

1. Select a mounting site that is representative of the monitoring environment. Consider the following when you select the mounting site.
  - Select a site that is easily accessible for servicing.
  - Select a site where the GD-K7D2 is not likely to be bumped or disturbed. Make sure there is sufficient room to make wiring and sample line connections at the bottom of the GD-K7D2. Also make sure there is sufficient room to perform start-up, maintenance, and calibration procedures.
  - Select a site near the sampling area. The GD-K7D2 is designed to detect a variety of toxic gases many of which are easily absorbed in sample tubing. See Table 2 below for recommended sample tubing lengths for various gases when using Teflon PTFE sample tubing. Contact RKI Instruments, Inc. for gases not listed.

**Table 2: Maximum Sample Tubing Lengths For Various Gases**

Target Gas	Maximum Sample Tubing Length
BF <sub>3</sub> (HF), ClF <sub>3</sub> , ClO <sub>2</sub> , F <sub>2</sub> , HF, O <sub>3</sub> , POCl <sub>3</sub> (HCl), WF <sub>6</sub> , TaF <sub>5</sub> (HF)	5 meters
BCl <sub>3</sub> (HCl), BR <sub>2</sub> , HBr, HCl, F <sub>2</sub> , NO, NO <sub>2</sub> , PCl <sub>3</sub> (HCl), POCl <sub>3</sub> , SbCl <sub>5</sub> (HCl), SiH <sub>2</sub> Cl <sub>2</sub> (HCl), SnCl <sub>4</sub> (HCl), SiCl <sub>4</sub> (HCl), SO <sub>2</sub> , TiCl <sub>4</sub> (HCl)	10 meters
Cl <sub>2</sub> , Si <sub>2</sub> H <sub>6</sub>	20 meters
AsH <sub>3</sub> , B <sub>2</sub> H <sub>6</sub> , CO, H <sub>2</sub> S, NH <sub>3</sub> , PH <sub>3</sub> , SiH <sub>4</sub>	30 meters
<i>Note: Gas in parenthesis indicates breakdown product of target gas being detected.</i>	

2. Use three #10 screws through the three mounting holes in the installation bracket to mount the installation bracket to a vertical surface. One of the mounting holes is round and the other two are slotted (See Figure 5).

**NOTE: All measurements in inches**

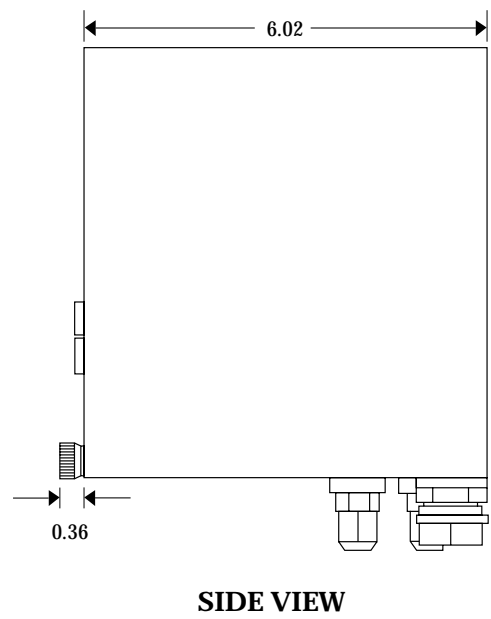
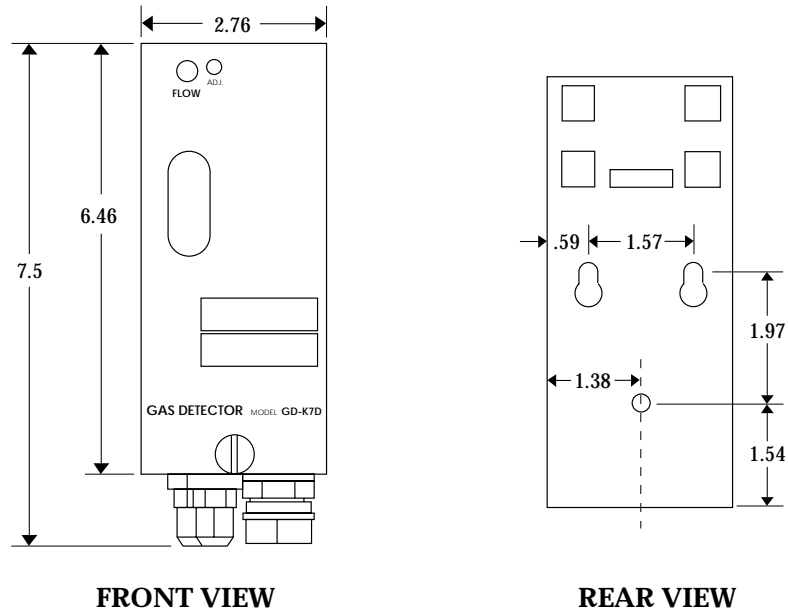

**Figure 5: Mounting the GD-K7D2**

**Connecting Sample Lines to the GD-K7D2**

1. When shipped from the factory, the tube nut, ferrule, and tube insert are shipped uninstalled and the open fittings are plugged with protective rubber plugs. Remove the protective plugs from the gas in and gas out fittings.
2. Install a short piece, up to 20 cm long, of 4 mm I.D. x 6 O.D. mm Teflon PTFE sample tubing to the gas in fitting as shown in Figure 6 below.

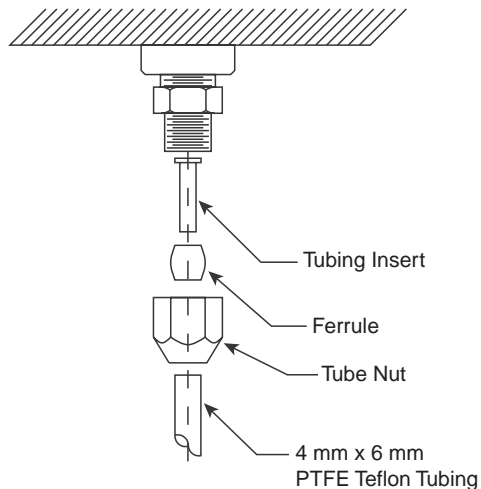

**Figure 6: Installing Tubing in the Sample Fittings**

3. Connect the sample filter to the tube. The sample filter has flexible tube stubs on each end. Push one end onto the sample tube.
4. Connect another length of sample tubing to the other side of the sample filter and route it to the sampling area. Be sure not to exceed the maximum sample tubing length listed in Table 2.

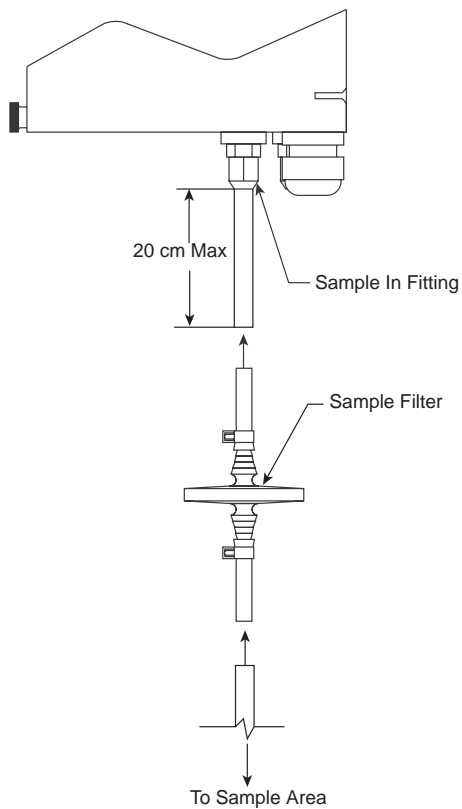

**Figure 7: Installing the Sample Filter**

---

**CAUTION:** *Avoid loops or slumps in the incoming sample line. To reduce response time, keep the incoming sample line as short as possible. See the Table 2 above for maximum sample tubing lengths.*

---

5. Attach 4 mm I.D. x 6 mm O.D. Teflon PTFE sample tubing to the gas out fitting. Route the opposite end of the tubing to an open area where the sample can safely disperse or to an exhaust duct.

### **Wiring the GD-K7D2 to a Controller**

---

**WARNING:** *Always verify that power to the GD-K7D2 and to the controller are off and that the controller's and GD-K7D2's power switches are in the off position before making wiring connections or adjustments.*

---

1. Turn off power to the controller and the GD-K7D2.
2. Place the controller's and GD-K7D2's power switches in the OFF position.
3. Guide a four or six conductor shielded cable through the cable bushing at the bottom of the GD-K7D2 installation unit.

A four conductor cable is used when the GD-K7D2 is wired to a controller that does not have flow alarm circuitry and flow alarm terminals for connection to the GD-K7D2 (see Figure 8 below). In this case, a jumper is factory installed between the second and third terminals from the right. If this jumper is not installed and the GD-K7D2 is being connected to a controller without flow alarm terminals, install a 20 gauge wire to jumper these two terminals.

A six conductor cable is used when the controller has flow alarm circuitry and flow alarm terminals for connection to the GD-K7D2 (see Figure 9 below).

---

**CAUTION:** *Leave the cable shield's drain wire insulated and disconnected at the GD-K7D2. You will connect the opposite end of the cable shield's drain wire at the controller.*

---

4. Connect two or four wires between the GD-K7D2 and the controller as shown in Figure 8 or Figure 9 depending on the controller used.

---

**CAUTION:** *At the controller, do not route power and GD-K7D2 wiring through the same conduit hub. The power cable may disrupt the transmission of the GD-K7D2's signal to the controller.*

---

---

**NOTE:** The controller connections shown are typical. See the controller Detector Head Specification Sheet for the GD-K7D2 or a controller specific wiring diagram for the GD-K7D2 for connections specific to the controller.

---

- Connect the remaining two wires to an appropriate AC power source as shown in Figure 8 and Figure 9.

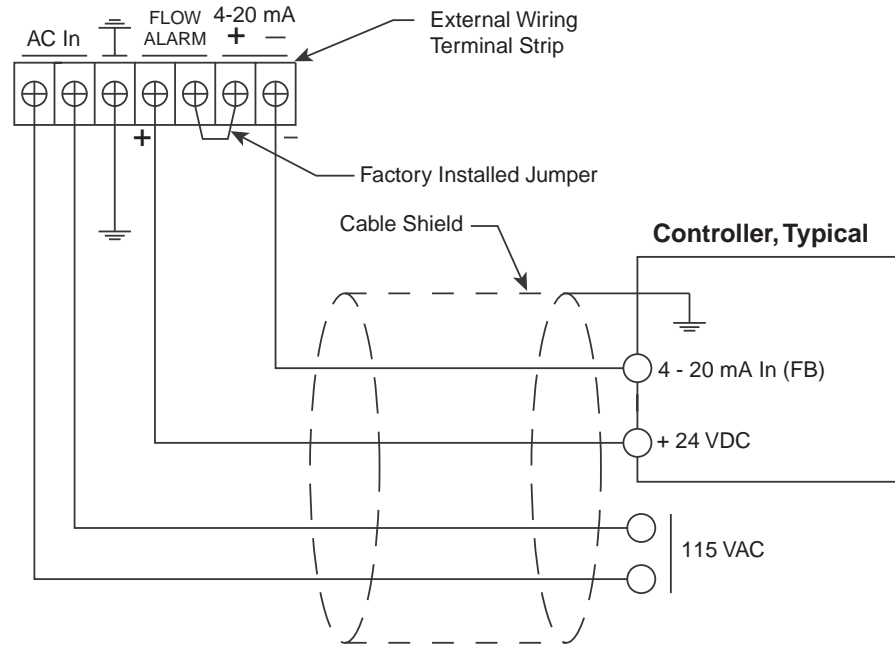

**Figure 8: Wiring the GD-K7D2 to a Controller Without Flow Alarm Terminals**

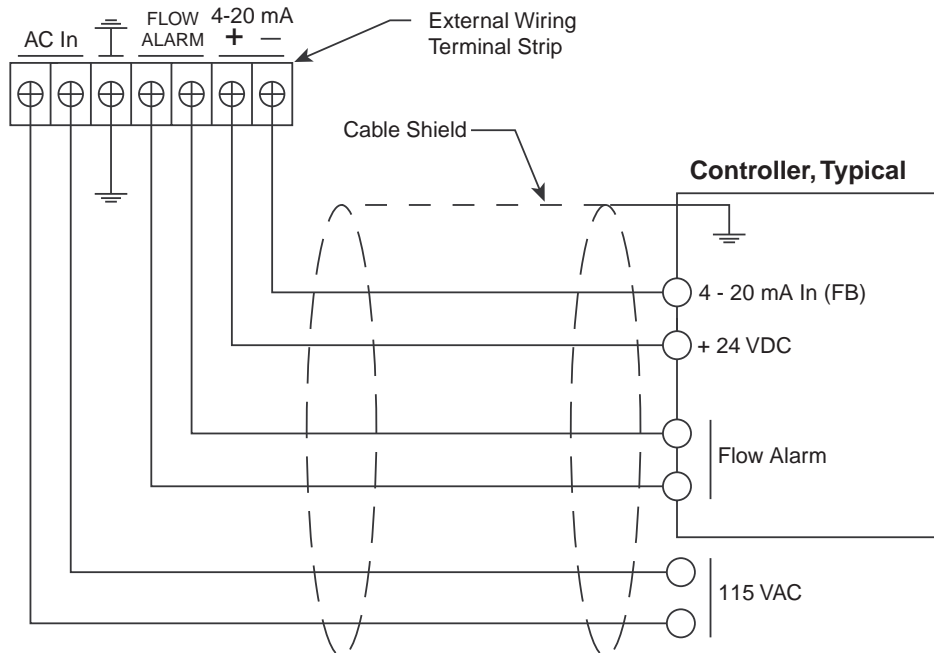

**Figure 9: Wiring the GD-K7D2 to a Controller With Flow Alarm Terminals**

- Connect the ground terminal to a locally available earth ground.

7. Connect the cable shield's drain wire to an available earth (chassis) ground at the controller. The grounding screw on each controller conduit hub is an example of an earth (chassis) ground.

### **Assembling the GD-K7D2**

1. Position the detection unit so the unit's main circuit board is aligned with the socket near the top of the installation unit and the internal plumbing is aligned near the bottom of each unit.
2. Push the detection unit into the installation bracket so the main circuit board plugs into the socket.
3. Tighten the captive screw in the lower left of the detection unit that secures the detection unit to the installation bracket.

---

## **Start Up**

This section describes procedures to start up the GD-K7D2 and place it into normal operation.

### **Introducing Incoming Power**

1. Complete the installation procedures described earlier in this manual.
2. Verify that the power wiring is correct and secure for the GD-K7D2 and the controller.
3. Turn on or plug in the incoming power to the controller.
4. Turn on the controller
5. Turn on or plug in the incoming AC power to the GD-K7D2, then place the GD-K7D2's power switch in the ON position.
6. Verify that the flowmeter ball is between the two lines on the flowmeter. If necessary, use the flow rate potentiometer to adjust the flow rate, so the flowmeter ball is between the two lines.
7. Verify that the incoming sample line is not leaking. To test the sample line, plug the open end of the sample line with your thumb. If the flowmeter ball drops to the bottom of the flowmeter, the incoming sample line is not leaking.

---

**CAUTION:** *Allow the GD-K7D2 to warm up for 30 minutes (2 hours for ammonia units) before you continue with the next section. If the lithium battery pack is dead and the GD-K7D2 has been off power for an extended period of time, allow the GD-K7D2 to warm up overnight.*

---

### **Setting the Zero Signal**

---

**CAUTION:** *If you suspect the presence of toxic gas in the monitoring environment, use the calibration kit and the zero air calibration cylinder to introduce "fresh air" to the sensor and verify an accurate zero setting.*

---

1. Verify that the GD-K7D2 is in a fresh air environment (environment known to be free of toxic and combustible gas and of normal oxygen content, 20.9%).
2. Unscrew the captive thumbscrew on the front of the cover and remove the cover from the GD-K7D2.
3. Use small test clips to connect a milliampmeter to the output check pins.



4. Verify a reading of 4.0 mA on the milliammeter. If necessary, use the zero pot to adjust the milliammeter reading to 4.0 mA.

---

**CAUTION:** *Do not adjust the span pot at this time unless a full calibration is performed. The GD-K7D2 is factory calibrated before shipment.*

---

5. Remove the milliammeter test clips.
6. Slide the housing cover over the detection unit and installation bracket, then tighten the thumbscrew at the front of the cover to secure the cover to the installation bracket.

---

## Operation

### Normal Operation

During normal operation, the GD-K7D2 will draw sample from the sample area and send the target gas reading to the controller via a 4 - 20 mA signal. The flowmeter ball should be between the two red lines. If the flowmeter ball is out of the red lines, use the flow adjustment pot to adjust the flow.

### Low Flow Alarm

If the GD-K7D2's flow rate drops low enough so that the flow ball is at the bottom of the flowmeter, the GD-K7D2 will go into low flow alarm after a delay of about one minute. When it is in low alarm, the flow light will turn off.

If the controller is the type that does not have flow alarm terminals, see Figure 8, then the GD-K7D2 will interrupt the 4 - 20 mA signal to the controller. This will cause the controller to indicate a fail alarm.

If the controller is the type that has flow alarm terminals, see Figure 9, then the GD-K7D2 will cause the controller to go into low flow alarm. See the controller instruction manual for more information.

---

## Maintenance

This section describes maintenance procedures for the GD-K7D2. It includes preventive maintenance and troubleshooting procedures.

### Preventive Maintenance

This section describes a preventive maintenance schedule to ensure the optimum performance of the GD-K7D2. It includes daily, monthly, and quarterly procedures.

#### *Daily*

1. Verify that the flow light on the front of the GD-K7D2 is on. If it is off, see the Troubleshooting section below.
2. Verify that the flowmeter ball is between the two lines on the flowmeter. If necessary, use the flow rate potentiometer to adjust the flow rate, so the flowmeter ball is between the two lines.
3. Verify a display reading of 0 at the controller. Investigate significant changes in the display reading.

#### *Monthly*

---

**NOTE:** Verifying the response of the GD-K7D2 may cause alarms. Be sure to put the controller into its calibration program or disable external alarms before verification.

---

This procedure describes a test to verify that the GD-K7D2 responds properly to the target gas.

#### *Preparing for the response test*

1. Verify that the display reading for the channel you plan to test is 0.  
If the display reading is not 0, set the zero reading of the GD-K7D2 as described in the Start Up section of this manual, then continue this procedure.
2. Assemble the calibration kit as described in the Calibration section of this manual.

---

**NOTE:** Do not connect the tubing from the GD-K7D2's gas in fitting to the regulator at this time.

---

3. Loosen the thumbscrew on the front of the cover, then remove the cover from the detection unit and installation bracket.
4. Use small test clips to connect a milliammeter to the output check pins.
5. Use the following formula to determine the correct GD-K7D2 (response) output for the calibrating sample.

$$\text{Response Output (mA)} = (\text{calibrating gas/fullscale}) \times 16 + 4$$

For example, if you have a cylinder of 5 ppm calibration gas with a GD-K7D2 full scale of 10 ppm:

$$12 \text{ mA} = (5 \text{ ppm}/10 \text{ ppm}) \times 16 + 4$$

### Performing the response test

---

**NOTE:** This procedure describes a response test using the RKI calibration kit that includes a “demand flow” regulator. A calibration kit that uses a gas collection bag is also available. Contact RKI Instruments, Inc. for more information concerning the gas collection bag accessory.

---

1. Disconnect the incoming Teflon sample tubing from the sample filter.
2. Connect the calibration kit sample tubing from the regulator to the sample filter. The GD-K7D2’s pump automatically begins pulling the gas from the calibration cylinder when you connect the GD-K7D2’s sample filter to the regulator.
3. Allow gas to flow for two minutes and verify the reading is within  $\pm 20\%$  of the response reading you determined earlier.

---

**NOTE:** If the reading is not within  $\pm 20\%$  of the correct response reading, calibrate the GD-K7D2 as described in the Calibration section of this manual.

---

4. Disconnect the calibration kit sample tubing from the sample filter.
5. Disconnect the calibration kit sample tubing from the regulator, then remove the milliammeter test clips from the output check pins.
6. Reinstall the incoming Teflon sample tubing to the sample filter.
7. Slide the cover over the detection unit and installation bracket, then tighten the thumbscrew at the front of the cover to secure it.
8. Disassemble the calibration kit as described in the Calibration section of this manual.
9. Allow time for the gas reading to return to normal and return the controller to normal operation.

---

**NOTE:** If the gas reading does not return to normal before returning the controller to normal operation, unwanted alarms may occur.

---

### ***Quarterly/Biannually***

Calibrate the GD-K7D2 as described in the Calibration section of this manual. The calibration frequency (every 3 to 6 months) depends on your specific application.

### **Troubleshooting**

The troubleshooting guide describes symptoms, probable causes, and recommended action for problems you may encounter with the GD-K7D2.

#### ***Fail Condition***

##### Symptoms

- The GD-K7D2’s flow light is off.

##### Probable causes

- The GD-K7D2 wiring to the controller is disconnected or misconnected.
- The AC power to the GD-K7D2 is interrupted.
- The GD-K7D2’s flow rate is too low because of an obstructed sample line, failed pump, etc.

- The GD-K7D2's ON/OFF switch is in the OFF position.
- The GD-K7D2 is malfunctioning.

Recommended action

1. At the GD-K7D2, set the correct flow rate with flow rate potentiometer.
2. If you cannot set the correct flow rate, check the sample lines for obstructions or kinks.
3. Verify that the GD-K7D2 wiring is correct and secure. The Installation section of this manual describes GD-K7D2 wiring connections.
4. Verify that the ON/OFF switch is in the ON position.
5. Verify that the GD-K7D2's AC power source is on and operational.
6. Calibrate the GD-K7D2 as described in the Calibration section of this manual.
7. If the fail condition continues, contact RKI Instruments, Inc. for further instruction.

**Slow or No Response/Difficult or Unable to Calibrate**

Symptoms

- The GD-K7D2 responds slowly or does not respond during the monthly response test.
- Unable to accurately set the zero or response reading during the calibration procedure.
- The GD-K7D2 requires frequent calibration.

---

**NOTE:** Under "normal" circumstances, the GD-K7D2 requires calibration every 3 - 6 months. Some applications may require a more frequent calibration schedule.

---

Probable causes

- The calibration cylinder is low, out-dated, or defective.
- The GD-K7D2's flow rate is too low because of obstructed sample line, failed pump, etc.
- The GD-K7D2 is malfunctioning.

Recommended action

1. Verify that the calibration cylinder contains an adequate supply of a fresh test sample.
2. If necessary, set the correct flow rate with the flow adjust potentiometer.
3. If you cannot set the correct flow rate, check the sample line for obstructions or kinks.
4. If a demand flow regulator is used for calibration, try a different demand flow regulator or a gas bag setup and see if the calibration/response difficulties continue.
5. If the calibration/response difficulties continue, replace the sensor.
6. If the calibration/response difficulties continue, contact RKI Instruments, Inc. for further instruction.

## Storing the GD-K7D2

The GD-K7D2 has a circuit on the main board that keeps a bias voltage on the gas sensor whenever there is no incoming power, such as during shipment, storage, or power outages. This circuit is powered by the lithium battery pack. If the lithium battery pack is dead when power to the GD-K7D2 is turned off or is lost, then the bias voltage normally on the sensor during operation will not be applied to the sensor. If the sensor is without the bias voltage for an extended period, it will take some time to stabilize and be ready for use after power is restored. If the sensor is off bias for too long, it may not be usable when power is restored.

The lithium battery pack will last approximately three years if the GD-K7D2 is on power all the time, approximately 2 years if it is on power for eight hours a day, and approximately 18 months if it is always off power. Be sure to replace the battery pack periodically to assure that the sensor will always be on bias during power outages.

If the GD-K7D2 is going to be stored, make sure a fresh battery pack is installed to maintain a bias on the sensor. See the next section for instructions to change the battery pack.

In addition to keeping the sensor on bias during storage, it must be kept upright. If the GD-K7D2 is stored, it must be oriented so that the sensor is upright.

---

**WARNING:** *If the GD-K7D2 is not stored in an upright position, the sensor membrane which allows gas into the sensor may dry out and the sensor may not recover proper operation.*

---

## Replacing Components of the GD-K7D2

### **Replacing the Fuse**

1. Turn off the controller.
2. Turn off power to the controller.
3. Turn off the 115 VAC power source to the GD-K7D2.
4. Place the GD-K7D2's ON/OFF switch in the OFF position.
5. Unscrew the captive thumbscrew on the cover and remove the cover.
6. Remove the four flat head screws on the top of the detection unit that hold down the metal cover over the main board.
7. Remove the old fuse from the fuse clips and replace it with the new one. See the parts list for the RKI part number for a replacement fuse.
8. Reinstall the metal main board cover with the four screws.
9. Reinstall the GD-K7D2 cover.
10. Turn on power to the controller and turn on the controller.
11. Turn on the 115 VAC power source to the GD-K7D2 and place the ON/OFF switch in the ON position.

### **Replacing the Sensor**

1. Turn off the controller.
2. Turn off power to the controller.
3. Turn off the 115 VAC power source to the GD-K7D2.

4. Place the GD-K7D2's ON/OFF switch in the OFF position.
5. Loosen the thumbscrew on the front of the housing cover, then remove the cover from the detection unit and installation bracket.
6. Rotate the clear plastic cover on the right side of the detection unit towards you to allow access to the amplifier and sensor.
7. A metal snap-in bracket holds the sensor in place. While facing the GD-K7D2, push this bracket to the left until it releases the sensor.
8. Gently push the sensor back, away from the sample cup, and slide it out of the right side of the detector unit with the amplifier cable still connected to the amplifier. The amplifier is attached to the sensor and will come out with the sensor.
9. Disconnect the amplifier cable from the amplifier. Gently pull on the connector to disconnect it.
10. Remove the retaining screw near the top of the amplifier that holds the amplifier to the sensor.
11. Disconnect the sensor connector at the bottom of the amplifier from the sensor by gently pulling the bottom of the amplifier away from the sensor.
12. Install the amplifier onto the new sensor with the sensor connector and retaining screw.
13. Connect the amplifier cable to the amplifier.
14. Reinstall the sensor into the sample cup.
15. Reinstall the sensor retaining bracket.
16. Reinstall the clear plastic cover on the right side of the detection unit.
17. Reinstall the GD-K7D2 cover.
18. Turn on power to the controller and turn on the controller.
19. Turn on the 115 VAC power source to the GD-K7D2 and place the ON/OFF switch in the ON position.
20. Calibrate the sensor as described in the Calibration section.

#### ***Replacing the Pump***

1. Turn off the controller.
2. Turn off power to the controller.
3. Turn off the 115 VAC power source to the GD-K7D2.
4. Place the GD-K7D2's ON/OFF switch in the OFF position.
5. Loosen the thumbscrew on the front of the housing cover, then remove the cover from the detection unit and installation bracket.
6. Loosen the captive screw in the lower left front of the detection unit that secures it to the installation bracket.
7. Pull the detection unit away from the installation bracket until the main board disengages from the socket, then lift it up slightly to free the detection unit from the installation bracket.
8. A metal snap-on bracket holds the pump in place. A tab on the bracket is accessible on the right side of the detector unit. Push the bracket tab back and away from the pump until the bracket snaps back and releases the pump.

9. Gently pull the pump towards the back of the detector unit until it disengages from the detector unit.
10. Disconnect the pump cable from the pump connector on the main board in the top of the detector unit and remove the cable from cable retainer near the connector. Note how the cable is routed to the connected.
11. Connect the new pump's cable to the pump connector and route the cable through the cable retainer like the old pump's cable.
12. Install the new pump into the detector unit and snap the retaining bracket back on.
13. Reinstall the detector unit into the installation bracket.
14. Reinstall the GD-K7D2 cover.
15. Turn on power to the controller and turn on the controller.
16. Turn on the 115 VAC power source to the GD-K7D2 and place the ON/OFF switch in the ON position.
17. Verify that the flow ball in the flowmeter is between the two red lines. Adjust the flow with the flow rate pot if necessary.

#### ***Replacing the Lithium Battery Pack***

---

**NOTE:** Change the lithium battery pack with the controller on and the GD-K7D2 on power and operating. If power to the GD-K7D2 is turned off to change the battery pack, the gas readings may be unstable for a short time when power is restored.

---

1. Loosen the thumbscrew on the front of the housing cover, then remove the cover from the detection unit and installation bracket.
2. Carefully pull the lithium battery pack away from the detector unit. It is installed in the detector unit with a strip of Velcro tape.
3. Carefully disconnect the battery pack cable connector from the main board by pulling it straight down, away from the main board. Do not touch the main board.
4. Carefully plug the cable connector from the new battery pack into the battery pack connector on main board. Do not touch the main board.
5. Install the new battery pack in the detection unit.
6. Reinstall the GD-K7D2 cover.

---

## Calibration

This section describes how to calibrate the GD-K7D2. It includes procedures to prepare for calibration, set the zero reading, set the response reading, and return to normal operation.

### Preparing for Calibration

---

**NOTE:** This procedure describes calibration using the RKI calibration kit that includes a “demand flow” regulator. A calibration kit that uses a gas collection bag is also available. Contact RKI Instruments, Inc. for more information concerning the gas collection bag accessory.

---

1. Put the controller into its calibration program or disable external alarms to avoid unwanted alarms during calibration.
  2. Screw the regulator into the zero air calibration cylinder.
- 

**NOTE:** If you can verify that the GD-K7D2 is drawing sample from a fresh air environment, you do not need to apply zero air to set the zero reading.

---

3. Disconnect the incoming Teflon sample tubing from the GD-K7D2’s sample filter.
  4. Connect the calibration kit sample tubing to the sample filter.
- 

**NOTE:** Do not connect the calibration kit sample tubing from the sample filter to the regulator at this time.

---

5. Loosen the thumbscrew on the front of the cover, then remove the cover from the detection unit and installation bracket.
6. Use small test clips to connect a milliampmeter to the output check pins.
7. Use the following formula to determine the correct GD-K7D2 (response) output for the calibrating sample.

$$\text{Response Output (mA)} = (\text{calibrating gas/fullscale}) \times 16 + 4$$

For example, if you have a cylinder of 5 ppm calibration gas with a GD-K7D2 full scale of 10 ppm:

$$12 \text{ mA} = (5 \text{ ppm}/10 \text{ ppm}) \times 16 + 4$$

### Setting the Zero Reading

---

1. Connect the calibration kit sample tubing from the sample filter to the regulator.
- 

**NOTE:** The GD-K7D2 pump automatically begins pulling the calibrating sample from the calibration cylinder when the calibration kit is completely assembled and connected to the GD-K7D2’s sample filter.

---

2. Allow the GD-K7D2 to draw gas for two minutes and verify a reading of 4.0 mA. If necessary, use the zero pot to adjust the reading to 4.0 mA.
3. Disconnect the calibration kit sample tubing from the regulator, then unscrew the regulator from the zero air calibration cylinder.

Leave the calibration kit sample tubing connected to the sample filter.



## Setting the Response Reading

1. Screw the regulator into the calibration cylinder.
2. Connect the calibration kit sample tubing from the GD-K7D2's sample filter to the regulator.
3. Allow the GD-K7D2 to draw gas for two minutes and verify that the reading matches the response reading you determined earlier. If necessary, use the span pot to adjust the reading to match the correct response reading.
4. Disconnect the calibration kit sample tubing from the sample filter.
5. Disconnect the calibration kit sample tubing from the regulator, then remove the milliammeter test clips from the output check pins.
6. Reinstall the incoming Teflon sample tubing to the sample filter.
7. Unscrew the regulator from the calibration cylinder.
8. Slide the housing cover over the GD-K7D2, then tighten the thumbscrew at the front of the cover to secure it to the GD-K7D2.
9. Allow time for the gas reading to return to normal, then return the controller to normal operation.

---

**NOTE:** If the gas reading does not return to normal before returning the controller to normal operation, unwanted alarms may occur.

---

10. Store the components of the calibration kit in a safe and convenient place.
11. Verify that the controller display reading decreases and stabilizes at 0 PPM.

## Parts List

Table 4 lists replacement parts and accessories for the GD-K7D2.

**Table 3: Parts List**

Part Number	Description
GD-K7D2-XXXX	GD-K7D2 transmitter (specify target gas when ordering)
30-1015RK	Replacement pump, w/cable & connector, for 115 VAC GD-K7D2
33-0165RK	Replacement filter, without flexible tubing stub on ends
33-0165RK-01	Replacement filter, with flexible tubing stub on ends
43-4155RK	Fuse, 5 mm x 20 mm, 2 amp, fast acting
49-1410RK	Lithium battery pack, 3.6 volts, for sensor bias backup
71-0077RK	<i>GD-K7D2 (115 VAC) Operator's Manual</i> (this document)
81-XXXX	Calibration kit (specify target gas when ordering)
81-XXXX	Calibration cylinder (specify target gas when ordering)
81-0076RK	Zero air calibration cylinder (17 liter)
81-0076RK-01	Zero air calibration cylinder (34 liter)
81-0076RK-03	Zero air calibration cylinder (103 liter)
81-1001RK	Dispensing valve (for use with gas collection bag and 17-liter zero air calibration cylinder)
81-1005RK	Regulator, fixed flow, 6.0 LPM, no gauge or knob, for 34, 58, & 103 liter cylinders.
81-1054RK	Regulator, demand flow, for 58 and 103 liter cylinders
81-1126RK	Gas collection bag
ES-23A-NO	Sensor, nitric oxide
ES-23AHS-ASH3	Sensor, arsine
ES-23AH-NO2	Sensor, nitrogen dioxide
ES-23AH-PH3	Sensor, phosphine
ES-23AH-SIH4	Sensor, silane (for scrubber applications, not interchangeable with ES-23DH-SIH4)
ES-23DH-SIH4	Sensor, silane, standard sensor (not interchangeable with ES-23AH-SIH4)
ES-23E-SO2	Sensor, sulfur dioxide, 0 - 15 ppm (not interchangeable with the ES-238-SO2)
ES-238-SO2	Sensor, sulfur dioxide, 0 - 10 ppm (not interchangeable with ES-23E-SO2)

**Table 3: Parts List**

<b>Part Number</b>	<b>Description</b>
ES-23R-NH3	Sensor, ammonia
ES-K233-CL2	Sensor, chlorine
ES-K233-F2	Sensor, fluorine
ES-K233-HCL	Sensor, hydrogen chloride
ES-K233-HF	Sensor, hydrogen fluoride
ES-K233-O3	Sensor, ozone