



INSTRUMENTS

**65-2670-XX-04
M2A Transmitter
Operator's Manual**

Part Number: 71-0518

Revision: D

Released: 6/24/21

WARNING

Read and understand this instruction manual before operating instrument. Improper use of the gas monitor could result in bodily harm or death.

Periodic calibration and maintenance of the gas monitor is essential for proper operation and correct readings. Please calibrate and maintain this instrument regularly! Frequency of calibration depends upon the type of use you have and the sensor types. Typical calibration frequencies for most applications are between 3 and 6 months, but can be required more often or less often based on your usage.

Product Warranty

RKI Instruments, Inc. warrants gas alarm equipment sold by us to be free from defects in materials, workmanship, and performance for a period of one year from date of shipment from RKI Instruments, Inc. Any parts found defective within that period will be repaired or replaced, at our option, free of charge. This warranty does not apply to those items which by their nature are subject to deterioration or consumption in normal service, and which must be cleaned, repaired, or replaced on a routine basis. Examples of such items are:

- a) Absorbent cartridges
- b) Pump diaphragms and valves
- c) Fuses
- d) Batteries
- e) Filter elements

Warranty is voided by abuse including mechanical damage, alteration, rough handling, or repair procedures not in accordance with the operator's manual. This warranty indicates the full extent of our liability, and we are not responsible for removal or replacement costs, local repair costs, transportation costs, or contingent expenses incurred without our prior approval.

THIS WARRANTY IS EXPRESSLY IN LIEU OF ANY AND ALL OTHER WARRANTIES AND REPRESENTATIONS, EXPRESSED OR IMPLIED, AND ALL OTHER OBLIGATIONS OR LIABILITIES ON THE PART OF RKI INSTRUMENTS, INC. INCLUDING BUT NOT LIMITED TO, THE WARRANTY OF MERCHANTABILITY OR FITNESS FOR A PARTICULAR PURPOSE. IN NO EVENT SHALL RKI INSTRUMENTS, INC. BE LIABLE FOR INDIRECT, INCIDENTAL, OR CONSEQUENTIAL LOSS OR DAMAGE OF ANY KIND CONNECTED WITH THE USE OF ITS PRODUCTS OR FAILURE OF ITS PRODUCTS TO FUNCTION OR OPERATE PROPERLY.

This warranty covers instruments and parts sold to users by authorized distributors, dealers, and representatives as appointed by RKI Instruments, Inc.

We do not assume indemnification for any accident or damage caused by the operation of this gas monitor, and our warranty is limited to the replacement of parts or our complete goods.

Table of Contents

Chapter 1: Introduction	6
Overview	6
About the M2A Transmitter	6
About this Manual	6
Specifications	7
Chapter 2: Description	9
Overview	9
External Description	9
Internal Description	12
Chapter 3: Installation & Startup	16
Overview	16
Mounting the M2A Transmitter	16
Wiring the M2A Transmitter	18
Start Up	21
Chapter 4: Operation	24
Overview	24
Normal Operation	24
Information Screen	24
4 - 20 mA Signal Output Operation	25
Alarm Indications	26
Chapter 5: Configuration Mode	29
Overview	29
Viewing & Changing M2A Parameters	29
Chapter 6: Gas Type Mode	32
Overview	32
Selecting the Gas Type	32

Chapter 7: Maintenance	35
Overview.....	35
Preventive Maintenance	35
Troubleshooting	35
Calibration Frequency.....	37
Calibration	38
Replacing Components of the Detector	41
Chapter 8: RS-485 Modbus Output	44
Overview.....	44
Wiring the M2A in a Modbus System	44
Using the M2A in a 4-wire Modbus System.....	48
Modbus Mode.....	48
Supported Modbus Functions.....	50
Chapter 9: Parts List	55
Appendix A: Control Button Quick Reference Guide	57
Appendix B: PLC and DCS Device Wiring	58
Appendix C: Function Code 16 Registers	60

Chapter 1: Introduction

Overview

This chapter briefly describes the 65-2670-XX-04 M2A Transmitter. This chapter also describes the *65-2670-XX-04 M2A Transmitter Operator's Manual* (this document). Table 1 at the end of this chapter lists the specifications for the M2A.

About the M2A Transmitter

The M2A transmitter is a fixed mount, continuous-monitoring detector head. All user adjustable parameters may be accessed using push button switches. In addition, calibration may be performed non-intrusively by use of a magnetic wand accessory which activates magnetic switches through a window at the front face of the detector head.

The M2A displays the current gas reading on an OLED display which is visible through the window in the cover (front face) and provides a 4 - 20 mA signal which indicates the target gas reading for use by a gas monitoring controller, recording device, or programmable controller. The M2A also provides an RS-485 Modbus output. Three sets of relay contacts, two controlled by the gas alarms and one by the fail alarm, rated at 115 VAC 5 amps are available for controlling devices such as lights or horns or for controlling higher rated relays.

Four operating modes allow you to display and change setup and calibration settings and change the gas type. They are Calibration Mode, Configuration Mode, Gas Type Mode, and Modbus Mode.

About this Manual

The *M2A Transmitter Operator's Manual* uses the following conventions for notes, cautions, and warnings.

NOTE: Describes additional or critical information.

CAUTION: *Describes potential damage to equipment.*

WARNING: *Describes potential danger that can result in injury or death.*

Specifications

Table 1 lists specifications for the M2A.

Table 1: M2A Specifications

Target Gas/Detection Range	<ul style="list-style-type: none"> • Ammonia (NH₃): 0 - 75.0 ppm, 0.1 ppm increments • Ammonia (NH₃): 0 - 100 ppm, 1 ppm increments • Ammonia (NH₃): 0 - 200 ppm, 1 ppm increments • Ammonia (NH₃): 0 - 500 ppm, 1 ppm increments • Chlorine (Cl₂): 0 - 3.00 ppm, 0.01 ppm increments • Chlorine (Cl₂): 0 - 5.00 ppm, 0.01 ppm increments • Chlorine (Cl₂): 0 - 10.0 ppm, 0.1 ppm increments • Chlorine Dioxide (ClO₂): 0 - 1.00 ppm, 0.01 ppm increments • Chlorine Dioxide (ClO₂): 0 - 3.00 ppm, 0.01 ppm increments • Chlorine Dioxide (ClO₂): 0 - 3.00 ppm, 0.01 ppm increments
Alarm Settings (Alarm 1/Alarm 2)*	<ul style="list-style-type: none"> • Ammonia (0 - 75.0 ppm <u>and</u> 0 - 100 ppm): 12 ppm / 25 ppm • Ammonia (0 - 200 ppm): 25 ppm / 35 ppm • Ammonia (0 - 500 ppm): 35 ppm / 300 ppm • Chlorine (0 - 3.00 ppm): 0.50 ppm / 1.00 ppm • Chlorine (0 - 5.00 ppm): 0.50 ppm / 1.50 ppm • Chlorine (0 - 10.0 ppm): 1.0 ppm / 3.0 ppm • Chlorine Dioxide (0 - 1.00 ppm): 0.10 ppm / 0.30 ppm • Chlorine Dioxide (0 - 3.00 ppm): 0.30 ppm / 1.00 ppm • Chlorine Dioxide (0 - 5.00 ppm): 0.50 ppm / 1.00 ppm
Sampling Method	Diffusion
Flow Rate for Calibration	0.25 LPM (using a 0.5 LPM regulator that is normally recommended for M2As will result in an inaccurate calibration)
Input Power	10 - 30 VDC
Controls	<ul style="list-style-type: none"> • Three push button switches • Three magnetic switches for non-intrusive calibration
Weight	5.5 lbs.
Signal Output	<ul style="list-style-type: none"> • 4 to 20 mA with impedance maximums listed below <ul style="list-style-type: none"> -12 VDC: 500 ohms impedance max -24 VDC: 1000 ohms impedance max • RS-485 Modbus
Operating Temperature	-20°C to 40°C
Accuracy	± 10% of reading or ± 5% of full scale (whichever is greater)
<p>* These are the RKI factory settings. You can change the alarm settings in Configuration Mode. See “Viewing & Changing M2A Parameters” on page 29.</p>	

WARNING: *When using the M2A, you must follow the instructions and warnings in this manual to assure proper and safe operation of the M2A and to minimize the risk of personal injury. Be sure to maintain and periodically calibrate the M2A as described in this manual.*

Chapter 2: Description

Overview

This chapter describes the components of the M2A transmitter. The transmitter is a 4 - 20 mA type detector head. It consists of the detector, calibration adapter/splash guard, terminal PCB, the M2A junction box, and the detector junction box. The two-junction-box configuration is intended for situations where the detector needs to be installed at an inaccessible location. The detector junction box can be installed at the inaccessible location and the M2A junction box can be installed in a more readily accessible area.

External Description

This section describes the junction boxes and all external components of the M2A transmitter.

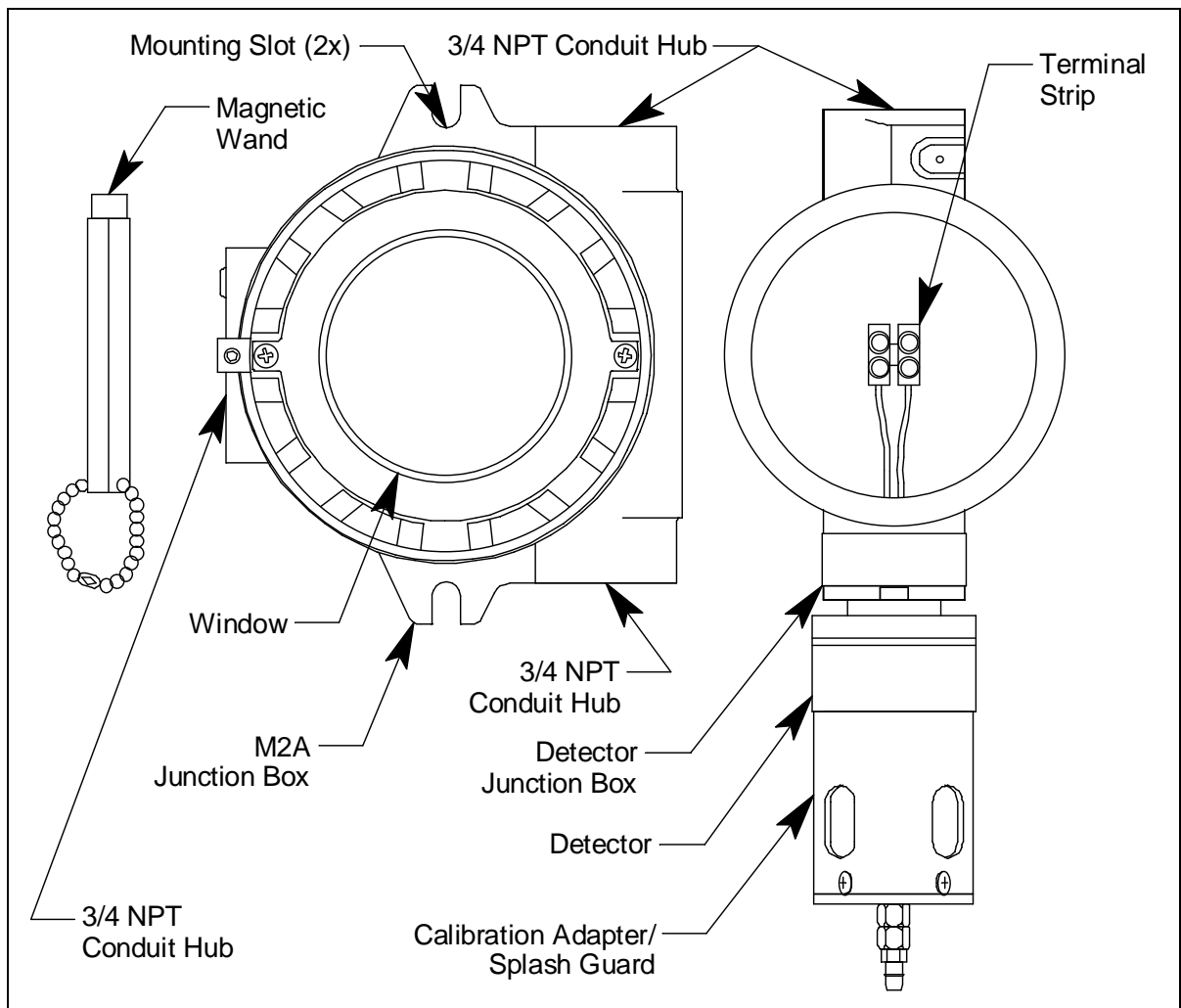

Figure 1: M2A External Components

M2A Junction Box

The M2A's cast aluminum junction box is dust and weather resistant. The junction box also protects the M2A and all connections made to it. Use the three 3/4 NPT conduit hubs to wire the remotely installed combustible gas detector and connect wiring from an external device, typically an RKI controller. The top hub is shipped with a factory installed and sealed conduit plug to avoid leaks into the junction box. If necessary, the conduit plug can be removed and the top hub can be used for wiring.

WARNING: *If the top conduit hub is used for wiring, be sure to seal the threads to ensure water does not enter the junction box. See "Wiring the M2A Transmitter" on page 18 for complete wiring instructions.*

Use the junction box's two mounting holes to mount the M2A to a vertical surface at the monitoring site. The window in the cover on the front of the junction box allows you to view the OLED display and use the magnetic wand to actuate the magnetic control switches so you can perform non-intrusive calibration. Removing the cover allows you to access the interior of the junction box.

Detector Junction Box

The detector junction box is intended to be installed remotely from the M2A junction box. The detector is factory installed in the bottom 3/4 NPT conduit hub. A terminal strip is provided for wiring connections and the detector is factory wired to one side of this terminal strip. The other side of the terminal strip is for user-supplied wiring to the detector terminal strip located in the M2A junction box. This wiring should go through the top 3/4 NPT conduit hub. Three spacers installed on the back of the junction box controls the distance of the junction box from a mounting surface. A ground boss near the top conduit hub provides an external earth ground connection.

Detector

The CT-7 style detector consists of the detector housing body, detector housing cap, cap gasket, and the plug-in sensor.

The table below outlines the M2A part numbers and replacement detector part numbers for the detectors.

Target Gas, Range	M2A Part Number	Detector Used
Cl ₂ , 0 - 3 ppm	65-2670-CL2-04	65-2302-CL2
Cl ₂ , 0 - 10 ppm	65-2670-CL210-4	65-2302-CL2-10
ClO ₂ , 0 - 1 ppm	65-2670-CLO2-04	65-2302-CLO2
ClO ₂ , 0 - 3 ppm	65-2670-CLO2-34	65-2302-CLO2-3
NH ₃ , 0 - 100 ppm	65-2670-NH3-1-4	65-2302-NH3-100
NH ₃ , 0 - 500 ppm	65-2670-NH3-5-4	65-2302-NH3-500

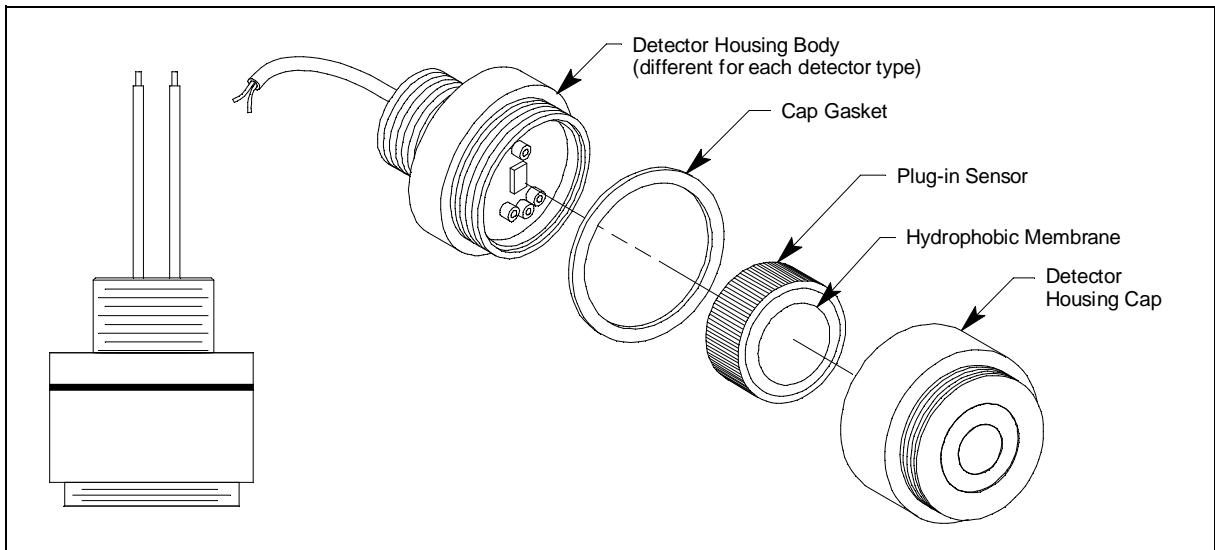

Figure 2: Detector Component Location

Detector Housing Body

The detector housing body protects the electronic components within the housing. Use the mounting threads at the top of the housing to screw the detector into the 3/4 NPT hub on the bottom of the detector junction box. Two wires extend from the top of the detector housing body. Use these wires to connect the detector to the terminal strip. One of the wires is color-coded for each detector type.

The housing includes a four-socket pattern. This socket pattern accepts the sensor's four pins to secure the sensor within the detector housing. A pre-amplifier, located between the sockets and two interconnect wires, conditions the sensor's signal before the signal reaches the controller.

Housing Cap & Cap Gasket

The housing cap screws onto the detector housing. An adhesive backed gasket inside the detector housing cap helps ensure that the sensor remains plugged into the detector housing body. It retains the plug-in sensor and protects it from damage. Unscrew the detector cap to access the plug-in sensor for maintenance or replacement. A cap gasket seals the interface between the housing and cap.

Plug-In Sensor

The sensor is secured within the detector assembly by the housing cap. Through a series of chemical and electrical reactions, the sensor produces an electrical output that corresponds to the detection range of the transmitter.

Calibration Adapter/Splash Guard

A calibration adapter/splash guard is installed on the detector. A fitting at the bottom of the calibration adapter/splash guard allows a length of tubing to be connected for calibration and routed to a more easily accessible location (near the M2A junction box is optimal for ease of calibration). The calibration adapter/splash guard also protects the detector from splashing water or direct water spray.

Magnetic Wand

The magnetic wand is a short plastic rod with a magnet in one end. It is used to actuate the magnetic control switches on the control PCB while the junction box cover is still installed so that non-intrusive calibration can be performed.

Internal Description

This section describes the internal components of the M2A. The internal components of the M2A include the terminal PCB which provides for all the wiring connections to the M2A and the control PCB which displays the gas reading and has the control buttons.

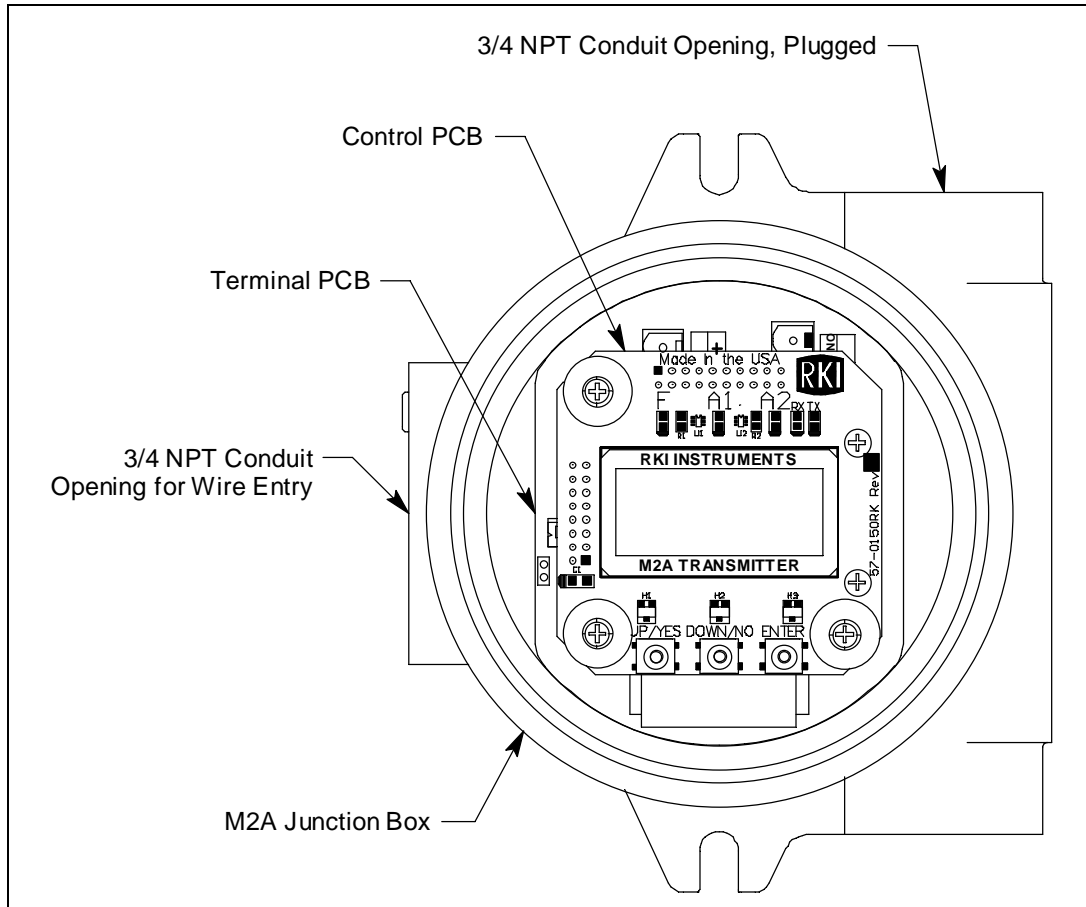

Figure 3: M2A Internal Components

Terminal PCB

The terminal PCB is encapsulated in epoxy for protection against moisture and physical damage. It is mounted into the rear of the junction box with three standoffs and rests on a thin layer of foam. A banana jack is screwed into each of the standoffs and used for mounting the control PCB. The terminal PCB converts the electrical output from the detector to a signal which can be displayed by the OLED display, a 4 - 20 mA signal (that is proportional to the detection range), and an RS-485 Modbus output signal. The 4 - 20 mA signal may be used by a recording device, gas monitor controller, or programmable controller. The Modbus output may be used to connect the M2A to a Modbus network. The terminal PCB also controls three relays, one fail and two gas alarm relays.

Two columns of plug-in style terminal strips are used to make all wiring connections to the M2A. The column on the left consists of the power/signal, detector, and Modbus terminal strips. The column on the right consists of the relay terminal strips. A 20 position connector at the bottom of the terminal PCB is used to connect the terminal PCB to the control PCB with a ribbon cable. A 5 position connector on the left side of the terminal PCB is used by factory or field service personnel to program the M2A.

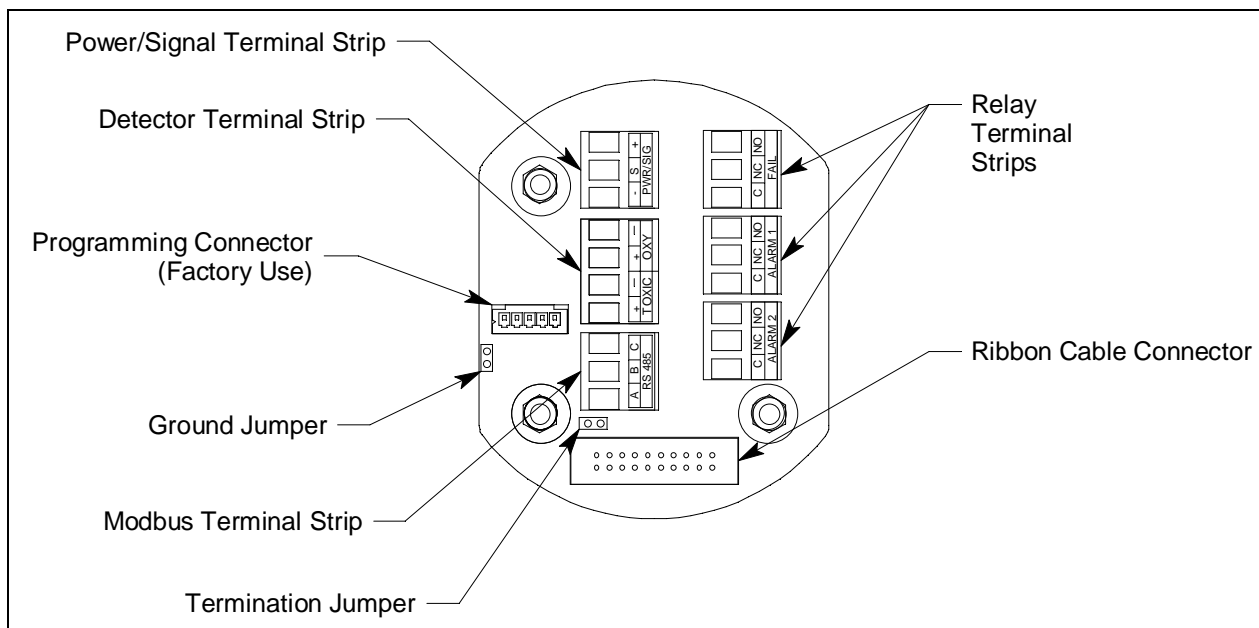

Figure 4: Terminal PCB Component Location

Power/Signal Terminal Strip

The power/signal terminal strip is a three position plug-in style terminal strip located at the top of the left terminal column. It is used to connect 24 VDC power to the M2A and to connect the 4 - 20 mA output signal to a device.

The signal output, the S terminal, does not have to be connected for the M2A to function. The S terminal is used if you want to connect the 4 - 20 mA output signal to another device such as a gas monitoring controller, chart recorder, or programmable controller (PLC).

Detector Terminal Strip

The detector terminal strip is a four position plug-in style terminal strip and is the middle terminal strip in the left terminal column. The two terminals labeled “TOXIC” are used to connect the detector to the M2A.

NOTE: The detector is factory-wired to the M2A. See “Wiring the M2A Transmitter” on page 18 for all wiring procedures related to M2A.

Modbus Terminal Strip

The Modbus terminal strip is a three position plug-in style terminal strip and is the bottom terminal strip in the left terminal column. It allows connection of the M2A into a Modbus network.

Relay Terminal Strips

The right column of terminal strips consists of, from top to bottom, the fail, alarm 1, and alarm 2 relay terminal strips. They are three-position plug-in style terminal strips. The relay terminal strips are used to connect devices such as lights and horns that are controlled by the relay contacts. The relay contacts are rated at 115 VAC, 5 amps. The relay contacts may also be used to control higher rated relays.

Termination Jumper

A two pin header with a termination jumper installed is located below the Modbus terminal strip. Leave this jumper installed unless directed to remove it for a Modbus installation. See “Chapter 8: RS-485 Modbus Output” on page 44 for a description of using the M2A in a Modbus system.

Ground Jumper

A two pin header with a jumper installed is located along the left side of the terminal PCB. Leave this jumper installed unless directed to remove it for a Modbus installation. See “Chapter 8: RS-485 Modbus Output” on page 44 for a description of using the M2A in a Modbus system.

Control PCB

The OLED display and control switches are located on the control PCB. It is installed on top of the terminal PCB by lining up its three spacing standoffs with the banana jacks in the terminal PCB mounting standoffs and pushing it onto the banana jacks. The jacks retain the control PCB.

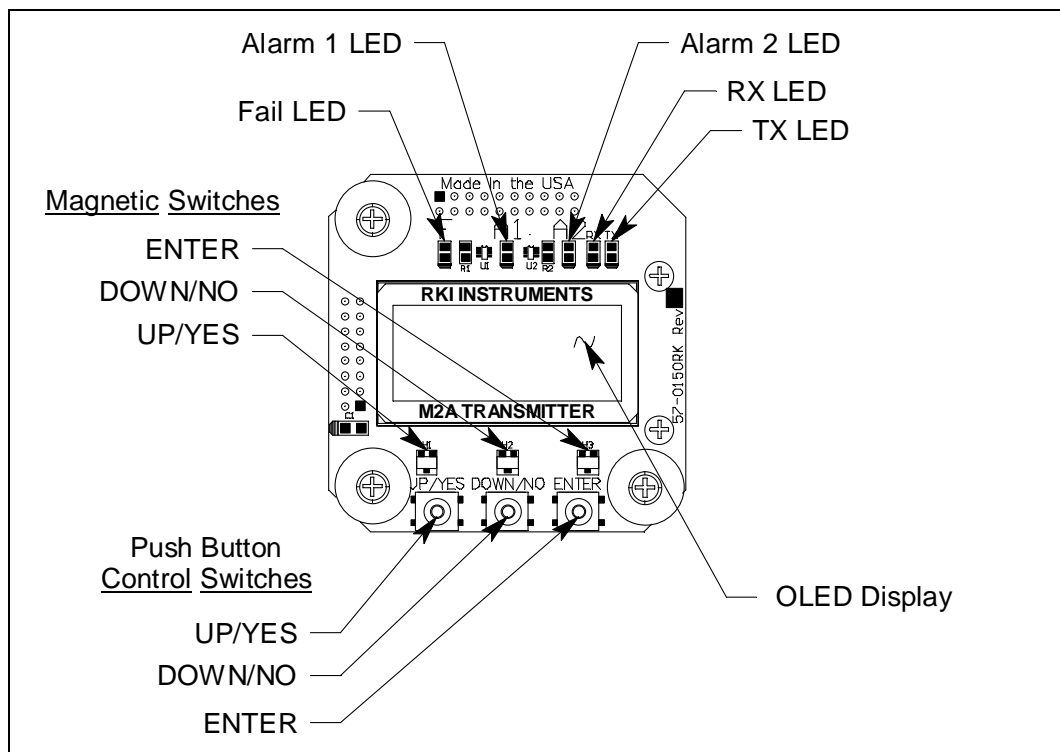

Figure 5: Control PCB Component Location

OLED Display

The OLED display is located at the top of the control PCB. It indicates the current gas reading and displays messages and parameters in the M2A’s programs.

Control Buttons

The M2A includes three push button switches that allow you to enter the M2A’s operating modes, navigate through the modes, update settings, and save changes to the settings. The push button switches are located along the bottom edge of the control PCB (see Figure 5). The UP/YES button is on the left, the DOWN/NO button is in the middle, and the ENTER button is on the right.

Table 2: M2A Control Button Functions

Switch	Function
UP (YES)	<ul style="list-style-type: none">• Saves settings• Changes the displayed setting• Enters the Calibration Program• Enters Gas Type Mode (press with DOWN/NO button)• Enters Configuration Mode (press with ENTER button)
DOWN (NO)	<ul style="list-style-type: none">• Cancels setting changes• Changes the displayed setting• Enters Gas Type Mode (press with UP/YES button)• Enters Modbus Mode (press with ENTER button)• Displays the Information Screen
ENTER	<ul style="list-style-type: none">• Initiates operations• Enters Configuration Mode (press with UP/YES button)• Enters Modbus Mode (press with DOWN/NO button)• Functions as an alarm reset switch

Just above each push button switch is a magnetic switch with the same function as the push button switch below it. The magnetic switches are for use in non-intrusive calibration. They are actuated by bringing the magnetic wand close enough to them to actuate them. Although the magnetic switches have the same functions as the push button switches, it is not practical to use them for operations other than calibration because it is not possible to actuate two magnetic switches at once with only one magnetic wand. Since displaying the Information Screen only requires the use of one switch, the wand may be used to show the Information Screen (see “Information Screen” on page 24).

Status LEDs

The M2A includes five status LEDs that are located above the display (see Figure 5).

- **Fail LED**

The fail LED turns on when the M2A is experiencing a fail condition. A fail condition can be caused by a detector failure or low detector signal.

- **Alarm 1 LED**

The alarm 1 LED is on when the M2A is experiencing an alarm 1 condition.

- **Alarm 2 LED**

The alarm 2 LED is on when the M2A is experiencing an alarm 2 condition.

- **RX & TX LED's**

These LED's indicate data being received (RX) and transmitted (TX) when the M2A's Modbus output is operating.

Chapter 3: Installation & Startup

Overview

This chapter describes procedures to mount the M2A Transmitter in the monitoring environment and wire it to input power and devices.

Mounting the M2A Transmitter

1. Select a mounting site that is representative of the monitoring environment. Consider the following when you select the mounting site.
 - For the M2A junction box, select a site where the junction box is not likely to be bumped or disturbed. Make sure there is sufficient room to perform start-up, maintenance, and calibration procedures. The site should be easily accessible.
 - For the detector junction box, select a site where the target gas is likely to be found first. For lighter gases, mount the detector near the ceiling; for heavier gases, mount the detector near the floor.
 - The junction boxes should be mounted no further than 200 feet from each other.
2. Use #10 screws through the M2A junction box's two mounting slots to secure the junction box to a vertical surface. Figure 6 shows the outline and mounting dimensions the M2A junction box. Figure 7 shows the outline and mounting dimensions for the detector junction box. Mount the detector junction box with the detector facing down as shown in Figure 7.

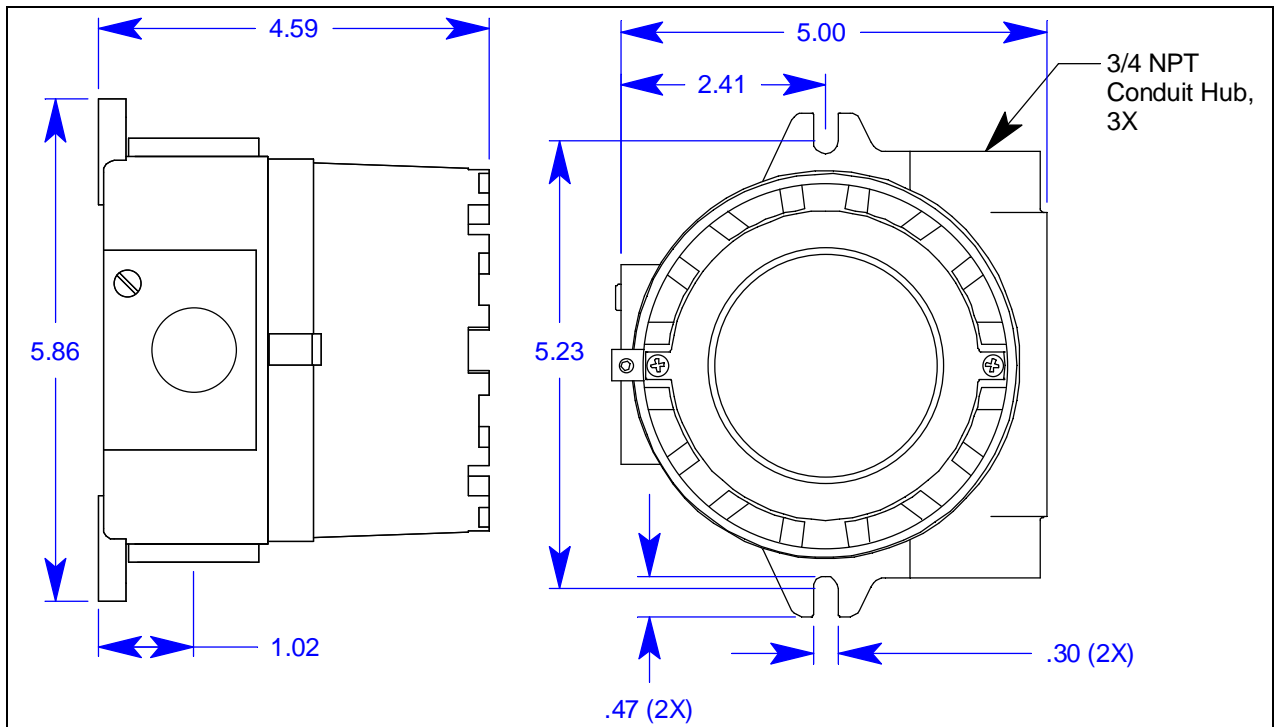

Figure 6: M2A Junction Box Dimensions

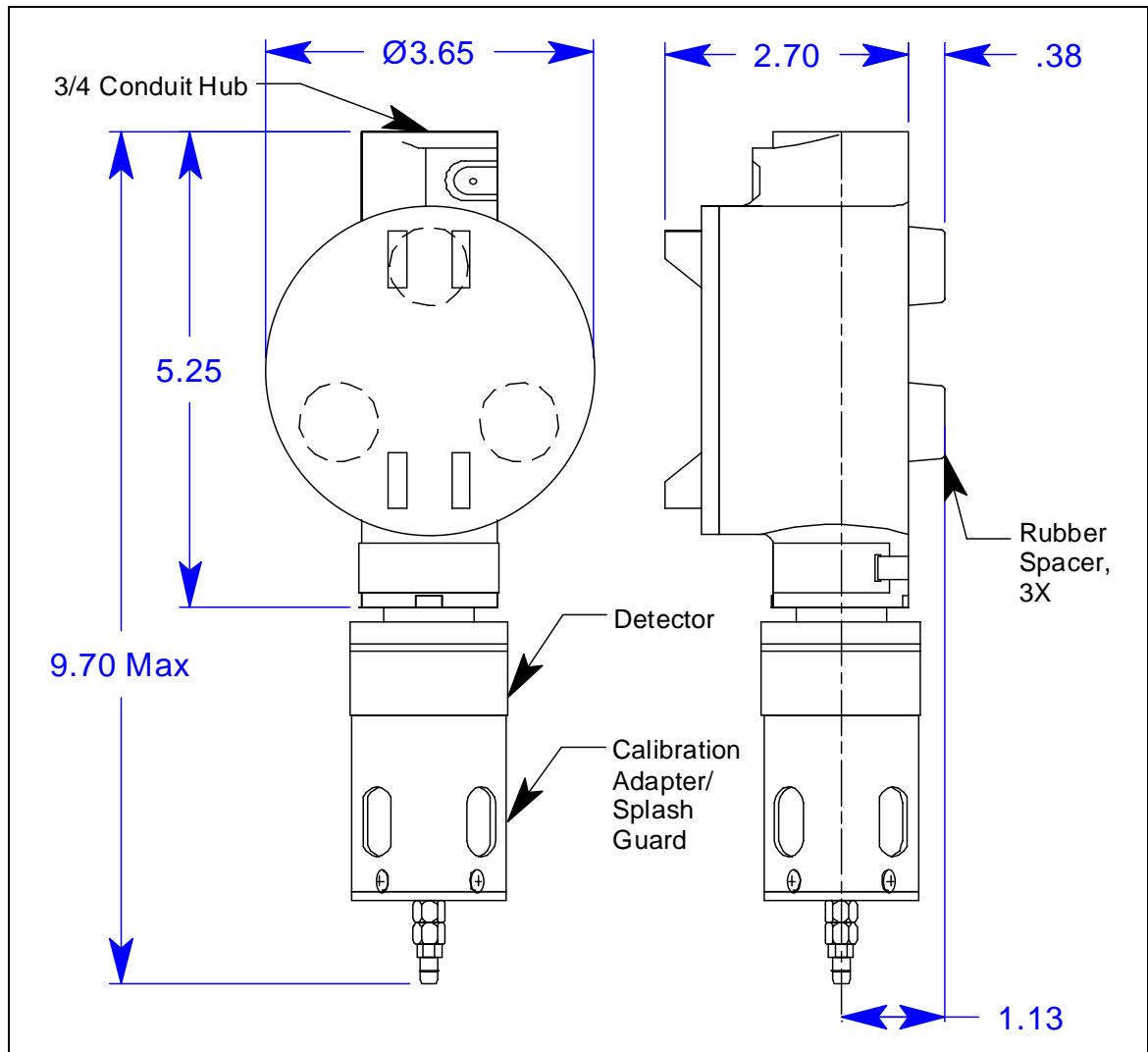

Figure 7: Detector Junction Box Dimensions

3. Tubing from the calibration adapter/splash guard must be 1/8 inch I.D. x 1/4 inch O.D. Teflon. Install a small piece of 3/16 inch I.D. flexible polyurethane tubing to each end of the Teflon tubing. Use the flexible tubing on one end to connect to the calibration adapter/splash guard. Route the Teflon tubing to an accessible area that is close to the M2A junction box. Use the flexible tubing on the other end to connect to a regulator during calibration. See the “Chapter 9: Parts List” on page 55 for available tubing.

Wiring the M2A Transmitter

Wiring the Detector to the M2A

WARNING: *Always verify that the power to the M2A is off before you make wiring connections.*

1. Confirm that no power is being applied to the M2A.
2. Remove the detector junction box's cover from the junction box.
3. Remove the M2A junction box's cover from the junction box.
4. Grasp the control PCB by its edges.
5. Gently pull until the control PCB is pulled away from the banana jacks. Take care not to pull too hard and damage the cable which connects the control and terminal PCBs.
6. Let the control PCB hang by the cable. The terminal strips are now visible on the terminal PCB. The control PCB may be left hanging while wiring is done. If desired, the control PCB may be disconnected from the cable and set aside while wiring.
7. To maintain the M2A junction box's NEMA 4X environmental rating and prevent water from entering the junction box through the conduit hubs, use appropriate construction technique.
8. Guide a two-conductor, shielded cable or two wires in conduit through the top conduit hub of the detector junction box. To make wiring more convenient, use wire colors that correspond to the detector wire colors: red and black.

Max Distance to M2A w/18 Gauge Wire	Max Distance to M2A w/16 Gauge Wire	Max Distance to M2A w/14 Gauge Wire
500 ft.	1,000 ft.	2,000 ft.

9. Connect the wires to the terminal block in the detector junction box.
10. Secure the detector junction box's cover to the junction box.
11. Guide the other end of the two-conductor, shielded cable or two wires in conduit through the bottom conduit hub of the M2A junction box.

WARNING: *If the top conduit hub is used for wiring, be sure to seal the threads to ensure water does not enter the junction box.*

12. To gain access to a plug-in terminal strip for wiring, pull it out of its socket by grasping the wall between two terminal positions with needle nose pliers and pulling. Be careful not to exert too much force on the wall to avoid damage to the terminal strip. The detector terminal strip and the alarm 1 relay terminal strip may be removed by grasping them with your fingers if the adjacent terminal strips have been removed.

13. Pull out the detector terminal strip and connect the two wires to the terminal strip as follows (see Figure 8).
- Connect the wire corresponding to the detector's red wire to the **TOXIC "+"** terminal.
 - Connect the wire corresponding to the detector's black wire to the **TOXIC "-"** terminal.

CAUTION: *If shielded cable is used, leave the cable shield's drain wire disconnected and insulated at the detector junction box. You will connect the opposite end of the cable's drain wire to the M2A junction box's chassis (earth) ground.*

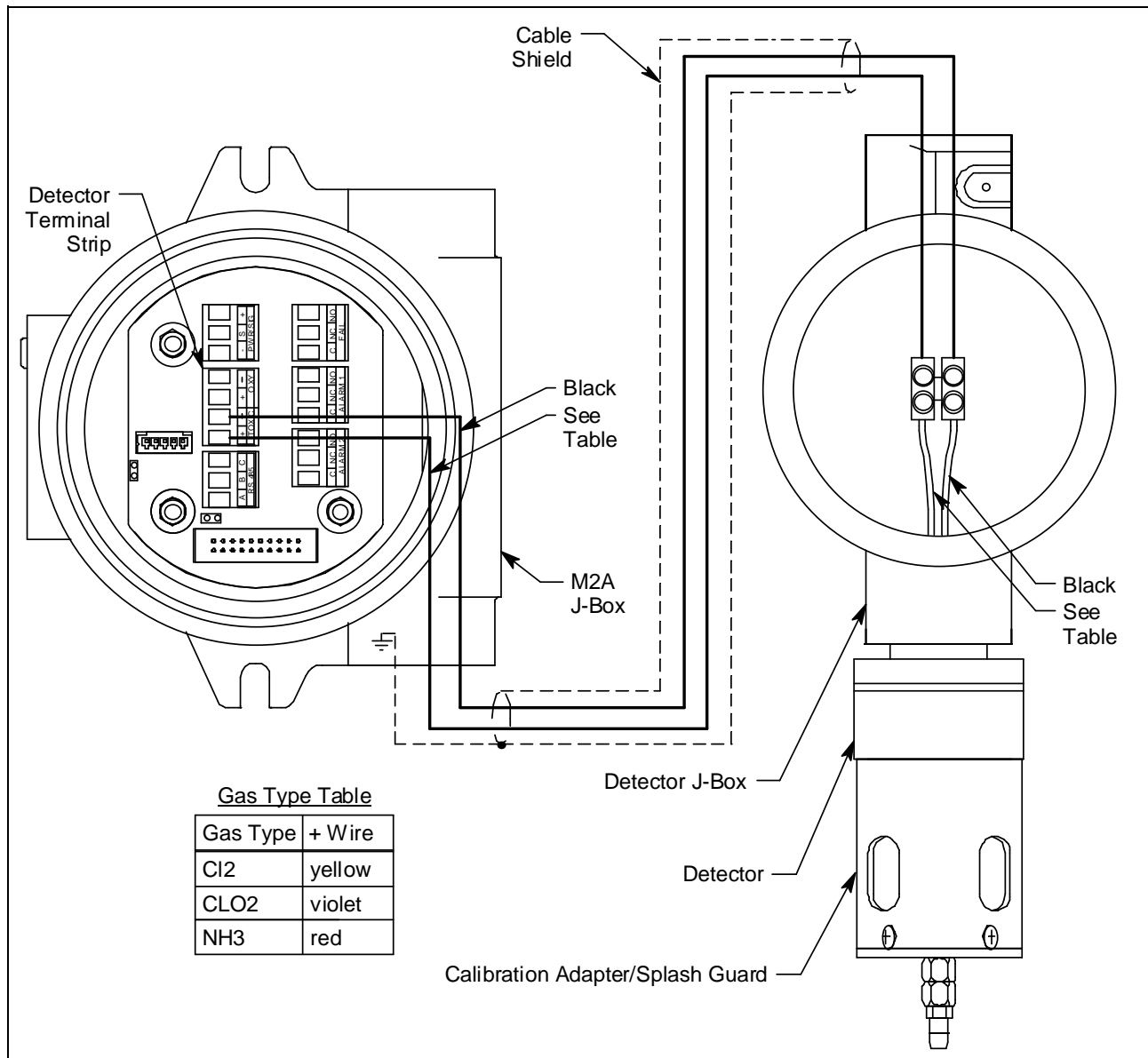

Figure 8: Wiring the Detector to the M2A

14. Reinstall the detector terminal strip into its socket.

15. If shielded cable is used between the detector junction box and the M2A junction box, connect the cable's drain wire to an available chassis (earth) ground at the M2A junction box. Do not connect the shield drain wire at the detector junction box.

Wiring the M2A to a Controller and Alarm Devices

1. Guide multi conductor shielded cable or cables or wires in conduit through the left conduit hub of the M2A junction box. The number of cables or wires needed will depend on whether the M2A is wired to a gas monitoring controller or just to power, whether any relays are used, and whether the Modbus output is used.

WARNING: *If the top conduit hub is used for wiring, be sure to seal the threads to ensure water does not enter the junction box.*

NOTE: If the M2A is being wired to a PLC or DCS device, see “Appendix B: PLC and DCS Device Wiring” on page 58, then continue with step 8.

Use the following recommendations to determine how to wire the M2A:

- If Modbus connections will not be used and only the PWR/SIG connections will be used, use a two or three conductor shielded cable or two or three wires in conduit for connections to the power/signal terminal strip depending on whether or not the signal (S) terminal is used. The S terminal has a 4 - 20 mA output, but if you do not need to monitor this signal and do not connect to the S terminal to access this signal, the M2A will still function completely.

Table 3: Wire Size for PWR/SIG Connections

Max Distance to Controller w/18 Gauge Wire	Max Distance to Controller w/16 Gauge Wire	Max Distance to Controller w/14 Gauge Wire
2,500 ft.	5,000 ft.	8,000 ft.

- If the PWR/SIG connections and one or more relays are used, route the connections to the M2A in conduit. Use shielded cable in the conduit for the PWR/SIG connections and unshielded cable or individual wires for the relay connections. Make sure any wire or cable used for relay wiring is appropriately rated for the power that it will carry.

CAUTION: *If shielded cable is used for the PWR/SIG connections, leave the cable shield's drain wire insulated and disconnected at the M2A junction box. You will connect the opposite end of the cable's drain wire at the controller or device.*

- If the M2A will be wired into a Modbus network, see “Chapter 8: RS-485 Modbus Output” on page 44.

See Figure 9 below for field wiring connections to the M2A.

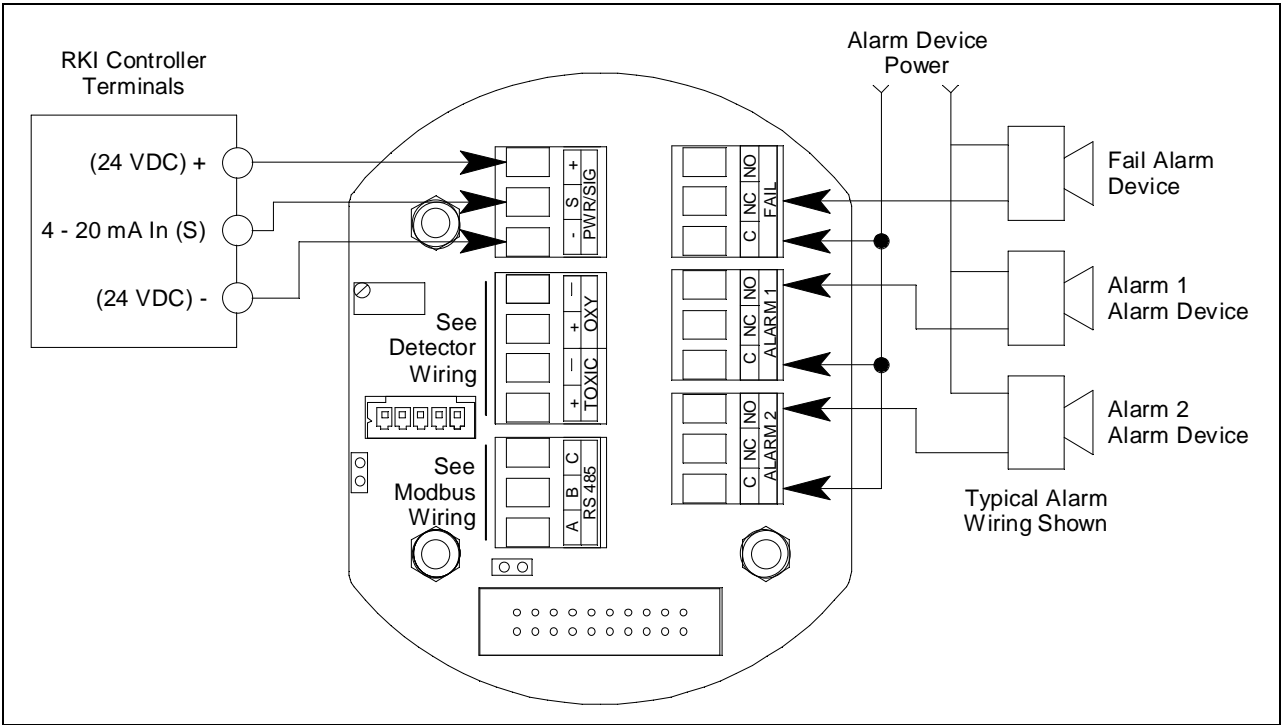

Figure 9: Wiring the M2A to a Controller and Alarm Devices

2. Re-install the control PCB (and ribbon cable if necessary). Be sure the ribbon cable is routed down below the control PCB so it will not be damaged by the cover when it is screwed back on.
3. Secure the M2A junction box cover to the junction box.
4. Make controller, device, and relay connections as appropriate. If shielded cable is used for the PWR/SIG connections, connect the cable shield's drain wire to an available chassis ground at the gas monitoring controller, recording device, or programmable controller.

Start Up

Introducing Incoming Power

1. Complete the installation procedures described earlier in this manual.
2. Verify that all wiring connections are correct and secure.
3. Turn on the incoming power.
4. If necessary, turn on the controller or other monitoring device that is connected to the M2A.
5. The OLED display will indicate the firmware version when the M2A is first powered up and will then count down a one minute warm-up period before normal operation begins. During normal operation, the display will indicate the target gas and current gas reading. Verify that the display is indicating the target gas and current gas reading after the warm-up period is complete and normal operation begins.

NH3
0 ppm

NOTE: For all gases except ClO₂: Allow the M2A's detector to warm up for 15 minutes before you continue with the next section, "Adjusting the Fresh Air Reading."

For ClO₂: All the M2A's detector to warm up for 2-3 hours before you continue with the next section, "Adjusting the Fresh Air Reading."

Adjusting the Fresh Air Reading

When the M2A is shipped from RKI Instruments, Inc., it is factory calibrated. If a full calibration is desired at startup, see "Calibration" on page 38.

Verify that the M2A is in a fresh air environment (environment known to be free of combustible or toxic gas vapors and of normal oxygen content, 20.9%).

CAUTION: *If you suspect the presence of the target gas in the monitoring environment, use the calibration kit and the zero air calibration cylinder to introduce "fresh air" to the detector and verify an accurate fresh air setting. See the "Calibration" on page 38 for instructions on how to use a zero air cylinder when performing a fresh air adjustment.*

Non-Intrusive Fresh Air Signal Adjustment

If the M2A is installed in a classified area and non-intrusive zero adjustment is required, follow the instructions below, **but do not remove the junction box cover**. Use the magnetic wand accessory to actuate the magnetic switches instead of pushing the control switch buttons. To actuate a magnetic switch and perform the same operation as pressing a control switch button, touch the magnet in the end of the magnetic wand to the M2A's glass cover directly over the magnetic switch you wish to actuate. Touching the glass and removing the wand is the same as pressing and releasing a button. Touching the glass and keeping the wand in place is the same as pressing and holding a button.

WARNING: *The M2A is not an active gas monitoring device during the fresh air adjustment procedure. The 4-20 mA output signal will "freeze" at 3.5 mA and all relays will remain in their non-alarm state while the M2A is in Calibration Mode. The output signal will not indicate current readings and the relays will not resume operating normally until the M2A is in normal operation again.*

NOTE: While in the calibration program, if there is no switch activity for the calibration time-out period the unit will return to normal operation. The factory set time-out is 15 minutes. If you want a different time-out period, see "Viewing & Changing M2A Parameters" on page 29 for instructions to change the calibration time-out.

1. While in normal operation, press and hold the UP/YES button for 5 seconds to enter Calibration Mode. Release the button when the following screen appears.

Calib? YES/NO

2. Press and release the UP/YES button to continue. The display will indicate the target gas and **CAL Mode** for a few seconds before showing **FreshAir Adjust?**.

3. Press and release the UP/YES button. **ENTER** will alternate with **FreshAir** on the top display line and the current gas reading will be on the bottom display line.
4. Press and release the ENTER button. The M2A will perform a zero operation and the display will indicate **SPAN w/Cal Gas?**.
5. Press and release the DOWN/NO button. The display will indicate **Leaving CAL Mode** and the M2A will return to normal operation.

Chapter 4: Operation

Overview

This chapter describes the M2A in normal operation. This chapter also describes the M2A in alarm 1, alarm 2, and fail conditions and suggests responses to these conditions.

Normal Operation

Normal operation is defined as follows:

- The start-up procedure is complete.
- The M2A is not indicating an alarm 1, alarm 2, or fail condition.
- The M2A is not in Calibration, Configuration, or Gas Type modes.

During normal operation, the M2A simultaneously displays the current gas reading, unit of measure, and target gas.

NH3 0 ppm

Information Screen

The Information Screen displays the M2A's operating voltage and firmware and hardware information. To display the Information Screen, do the following:

1. Press and hold the DOWN/NO button for 3 seconds. The Information Screen will appear.

24.2V v5.0L 2A

2. Continue holding the DOWN/NO button to keep the Information Screen on the display. The top line indicates the operating voltage that is connected to the M2A. The second line indicates the firmware that is running, version 5.0 in this example, and the M2A's hardware version, version 2A in this example. This information may be useful if you need to contact the factory with questions about the M2A.
3. Release the DOWN/NO button when you are done viewing the Information Screen. The display will return to the normal operation screen within a couple of seconds.

4 - 20 mA Signal Output Operation

The output at the S terminal of the power/signal terminal strip is a 4 - 20 mA signal that corresponds to the detection range of the M2A. During normal operation, this signal tracks the gas concentration on the OLED display.

There are several circumstances where the signal output will not track the display reading but will behave as follows:

- When the M2A is in its warm-up period, the signal output will be fixed at 3.5 mA (zero).
- When the M2A's gas type is changed, the M2A will enter Configuration Mode for you to verify the parameter settings. When you exit Configuration Mode, the display will indicate **NEEDS CALIBRATION** and will continue to indicate this until Calibration Mode is entered and a calibration is performed. In this situation, the signal output will be fixed at 3.5 mA from the time Gas Type Mode is entered until the M2A is calibrated and returns to normal operation.
- If you enter Calibration Mode, Configuration Mode, Gas Type Mode, or Modbus Mode, the signal output will be fixed at 3.5 mA until the M2A returns to normal operation.
- If the M2A's input power decreases below 9.5 volts so that the M2A is in a low power alarm, the signal output is fixed below 2.4 mA until the low power alarm is cleared.
- If the M2A goes into a fail condition, after a 30 second delay, the signal output is fixed below 2.4 mA until the fail alarm is cleared. During the 30 second delay, the signal output follows the detector output. In the case of a downscale reading, the display and the signal output continue to track the reading down to -99% of full scale (1.15 mA).

Alarm Indications

NOTE: The M2A includes alarm on and alarm off delay settings for alarm 1 and alarm 2. The alarm indications described in this section operate according to the factory set alarm settings. See Table 5 on page 30 for all the factory settings.

Table 4: Visual and Audible Alarm Indications

Condition	Cause	Visual Indication(s)
Alarm 1 ¹	Increasing gas reading at or above the alarm 1 setpoint	<ul style="list-style-type: none"> A1 LED is on Gas reading alternates with ALARM-1 message
Alarm 2 ¹	Increasing gas reading at or above the alarm 2 setpoint	<ul style="list-style-type: none"> A2 LED is on Gas reading alternates with ALARM-2 message
Fail	<ul style="list-style-type: none"> Disconnected or misconnected detector wiring The plug-in sensor is not properly plugged into the socket in the detector housing body. <p>NOTE: It could take up to 40 minutes for a disconnected NH₃ plug-in sensor to trigger a fail condition.</p> <ul style="list-style-type: none"> Display reading at -10% of full scale or lower Defective components 	<ul style="list-style-type: none"> F LED is on FAIL message replaces gas reading <p>NOTE: There is a 30 second delay on the fail condition.</p>
Low Power	DC power source less than 9.5 volts.	<ul style="list-style-type: none"> F LED is on LowPower message and actual voltage of incoming DC power
* ¹ If the M2A is in both an alarm 1 and an alarm 2 condition, both alarm LEDs are on and the display alternates between the gas reading and the ALMS 1&2 message.		

NOTE: You can select normally energized (N. EN) or normally de-energized (N. DE-EN) alarm 1 and alarm 2 relay settings in Configuration Mode. The following sections describe the standard factory setting for these relays which is N. DE-EN.

The fail relay is factory set as N. EN and is not user-adjustable.

Alarm 1 Condition

Alarm 1 Condition Indications

When the gas reading reaches the alarm 1 setpoint, the M2A senses an alarm 1 condition. The M2A alerts you to an alarm 1 condition as follows:

- The A1 LED turns on.
- The gas reading alternates with the **ALARM-1** message.

- The alarm 1 relay energizes.

Responding to an Alarm 1 Condition

1. Follow your established procedure for a low level toxic gas condition.
2. After the gas reading falls below the alarm 1 setpoint, press the ENTER button to reset the alarm 1 circuit. Resetting the alarm 1 circuit turns off the A1 LED, resets the OLED display, and de-energizes the alarm 1 relay.

NOTE: If the ENTER button is pressed while the M2A is in an alarm 1 condition, the A1 LED will flash but all other indications will remain unchanged.

You cannot de-energize the alarm 1 relay until the gas reading falls below the alarm 1 setpoint.

Alarm 2 Condition

Alarm 2 Condition Indications

When the gas reading reaches the alarm 2 setpoint, the M2A senses an alarm 2 condition. The M2A alerts you to an alarm 2 condition as follows:

- The A2 LED turns on.
- The gas reading alternates with the **ALARM-2** message.
- The alarm 2 relay energizes.

If the M2A is in both an alarm 1 and alarm 2 condition, both the A1 and A2 LEDs will be on, the gas reading will alternate with the **ALMS 1&2** message, and both alarm relays will energize.

Responding to an Alarm 2 Condition

1. Follow your established procedure for a high level toxic gas condition.
2. After the gas reading falls below the alarm 2 setpoint, press the ENTER button to reset the alarm circuit. Resetting the alarm circuit turns off the A2 light, resets the OLED display, and de-energizes the alarm 2 relay.

NOTE: If the ENTER button is pressed while the M2A is in an alarm 2 condition, the A2 LED will flash but all other indications will remain unchanged.

You cannot de-energize the alarm 2 relay until the gas reading falls below the alarm 2 setpoint.

Fail Condition

Fail Condition Indications

The M2A indicates a fail condition for any of the following:

- The detector wiring is disconnected or incorrectly connected.
- The plug-in sensor is not properly plugged into the socket in the detector housing body.

NOTE: It could take up to 40 minutes for a disconnected NH₃ plug-in sensor to trigger a fail condition.

- The display reading is -10% of full scale or lower.

When the M2A senses a fail condition, it alerts you as follows:

- The F LED turns on.
 - The gas reading is replaced by the **FAIL** message.
 - The fail relay de-energizes.
-

NOTE: The fail alarm has a 30 second delay.

Responding to a Fail Condition

1. Verify that the detector wiring is correctly and securely connected.

Low Power Alarm

Low Power Alarm Indications

The M2A senses a low power condition when the DC power source is 9.5 volts or less.

WARNING: *While in a low power condition, the M2A is not an active gas monitor.*

When the M2A senses a low power condition, it alerts you as follows:

- The F LED turns on.
 - The message **LowPower** is indicated on the top line of the OLED display and the input voltage is displayed on the bottom line of the OLED display.
 - The fail relay de-energizes.
-

NOTE: The low power alarm cannot be cleared using the ENTER button.

When the voltage increases to 10.0 volts, the low power alarm is cleared and the M2A will begin its warm-up sequence.

Responding to a Low Power Condition

1. Determine and correct the cause of the low power condition.
2. When the input power increases above 10.0 volts, the M2A will begin its warm-up sequence.
3. Verify that the M2A enters normal operation after its warm-up sequence. If necessary, perform a fresh air adjustment. See “Adjusting the Fresh Air Reading” on page 22.

Chapter 5: Configuration Mode

Overview

This chapter describes how to view and change M2A parameters using Configuration Mode. It is accessed using the program buttons.

Configuration Mode includes a 5-minute time-out feature. If you do not press a control button for 5 minutes, the M2A automatically returns to normal operation.

NOTE: If the M2A returns to normal operation because of a time-out, it enters a warm-up period just as it does when it is first turned on.

If you are installing a new M2A, it has been setup at the factory. Use Configuration Mode only if you want to change the M2A's setup. If you want to change the detector type see "Chapter 6: Gas Type Mode" on page 32.

Viewing & Changing M2A Parameters

1. While in normal operation, simultaneously press and hold the UP/YES and ENTER buttons for 5 seconds to enter Configuration Mode. Release the buttons when the following screen appears.

Enter
Config?

2. If you want to exit Configuration Mode, press and release the DOWN/NO button and the M2A will return to normal operation.

If you want to continue in Configuration Mode, press and release the UP/YES button. The target gas and the full scale will be displayed for a few seconds before the first adjustable parameter, the alarm 1 setpoint, is displayed.

3. If you want to change the currently displayed parameter, use the UP/YES and DOWN/NO buttons to adjust it to the desired setting, then press ENTER to continue to the next parameter.

If the currently displayed parameter is OK, press the ENTER button to proceed to the next parameter.

Table 5 lists the M2A parameters you can set. Table 5 also lists the factory set value for each parameter.

Table 5: Configuration Parameters

Parameter (Factory Set Value)	Description
ALARM-1 (level) (25 ppm)	The gas reading at which the M2A initiates an alarm 1 condition.
ALARM-1 (activation) (Increase)	Indicates if the alarm 1 circuit is activated by gas readings increasing (Increase) or decreasing (Decrease) to the ALARM-1 Level.
ALARM-1 (relay action) (N. DE-EN)	If set as N. DE-EN , the alarm 1 relay is de-energized in normal operation and energizes when an alarm 1 condition is initiated. If set as N. EN , the alarm 1 relay is energized in normal operation and de-energizes when an alarm 1 condition is initiated.
ALARM-1 (relay reset) (LATCH)	If set as LATCH , you must press the ENTER button to reset the alarm 1 circuit after the alarm 1 condition passes. If set as SELF-RST , the M2A automatically resets the alarm 1 circuit after the alarm 1 condition passes.
A1 OnDy (alarm 1 on delay) (1 secs)	The amount of time the M2A delays activation of the alarm 1 circuit once an alarm 1 condition is initiated. It can be set in 1 second increments from 0 - 60 seconds, in 1 minute increments from 1 - 15 minutes, and in 15 minute increments from 15 - 60 minutes.
A1 OffDy (alarm 1 off delay) (0 sec.)	The amount of time the M2A delays turning off the alarm 1 circuit once an alarm 1 condition passes. This parameter appears only if the alarm 1 relay reset setting is set to SELF-RST . It can be set in 1 second increments from 0 - 60 seconds, in 1 minute increments from 1 - 15 minutes, and in 15 minute increments from 15 - 60 minutes.
ALARM-2 (level) (50 ppm)	The gas reading at which the M2A initiates an alarm 2 condition.
ALARM-2 (activation) (Increase)	Indicates if the alarm 2 circuit is activated by gas readings increasing (Increase) or decreasing (Decrease) to the ALARM-1 Level.
ALARM-2 (relay action) (N. DE-EN)	If set as N. DE-EN , the alarm 2 relay is de-energized in normal operation and energizes when an alarm 2 condition is initiated. If set as N. EN , the alarm 2 relay is energized in normal operation and de-energizes when an alarm 2 condition is initiated.
ALARM-2 (relay reset) (LATCH)	If set as LATCH , you must press the ENTER button to reset the alarm 2 circuit after the alarm 2 condition passes. If set as SELF-RST , the M2A automatically resets the alarm 2 circuit after the alarm 2 condition passes.
A2 OnDy (alarm 2 on delay) (1 secs)	The amount of time the M2A delays activation of the alarm 2 circuit once an alarm 2 condition is initiated. It can be set in 1 second increments from 0 - 60 seconds, in 1 minute increments from 1 - 15 minutes, and in 15 minute increments from 15 - 60 minutes.

Table 5: Configuration Parameters

Parameter (Factory Set Value)	Description
A2 OffDy (alarm 2 off delay) (0 sec.)	The amount of time the M2A delays turning off the alarm 2 circuit once an alarm 2 condition passes. This parameter appears only if the alarm 2 relay reset setting is set to SELF-RST . It can be set in 1 second increments from 0 - 60 seconds, in 1 minute increments from 1 - 15 minutes, and in 15 minute increments from 15 - 60 minutes.
ZeroSupp (2 ppm)	The zero suppression feature helps prevent “jumpy” readings near the fresh air reading. For example, if the zero suppression is 2.0 ppm , the M2A will display a reading of 0 ppm for gas readings from -2 ppm to 2 ppm. It is settable from 0 to 6% of the detection range.
FILTER (5 secs)	The filter feature helps “smooth out” jumpy or noisy signals from the detector. You can set the filter from 0 seconds to 60 seconds in 5 seconds increments. The displayed gas reading is the average reading over the previous time period defined by the filter setting. So if the filter is set to 5 seconds, the displayed gas reading is the average over the past 5 seconds.
CAL Time (15 mins)	The calibration time-out sets the amount of time after the last button push while in Calibration Mode that the M2A will wait before returning to normal operation. If the calibration time-out is set to 15 mins , then M2A will return to normal operation automatically 15 minutes after the last button push.
Auto Zero (Enabled)	If set to Enabled , the M2A’s firmware will monitor the zero (fresh air) reading and make automatic zero adjustments under precisely specified conditions if it determines that a reading change is due to normal sensor drift. If set to Disabled , the Auto Zero function is turned off.

- When you have scrolled through all the adjustable parameters, **SAVE IT? YES/NO** appears on the display.
- If you do not wish to save the adjustments and want to exit Configuration Mode, press and release the DOWN/NO button. The **DO OVER? YES/NO** message will display. Press and release the DOWN/NO button. The **ABORT? YES/NO** message will display. Press the UP/YES button to return to normal operation.

If you wish to change some of the adjustments made, press and release the DOWN/NO button. The **DO OVER? YES/NO** message will display. Press and release the UP/YES button. The **Re-do Config** message will display and the M2A will return to the first adjustable parameter. Go back to step 3 and continue.

If you wish to save the adjustments made, press and release the UP/YES button. **Config Saved** is indicated on the display for a few seconds and the M2A returns to normal operation.

Chapter 6: Gas Type Mode

Overview

This chapter describes how to use Gas Type Mode to select the M2A's gas type. The gas type determines the target gas and detection range.

CAUTION: *The target gas is factory set and does not normally need to be changed.*

Gas Type Mode includes a 5-minute time-out feature. If you do not press a button for 5 minutes, the M2A automatically returns to normal operation.

NOTE: If the M2A enters normal operation because of a program time-out, it enters a warm-up period just as it does when it is first turned on.

Selecting the Gas Type

1. While in normal operation or during the warm-up sequence, press and hold the UP/YES and DOWN/NO buttons for five seconds. Release them when the following screen appears.

Select GasType?

2. If you want to exit Gas Type Mode, press and release the DOWN/NO button. The display will indicate **NO CHANGE** and the M2A will return to normal operation.

If you want to continue in Gas Type Mode, press and release the UP/YES button. The top display line will indicate **GasType?** and the bottom display line will indicate the target gas choice.

3. Use the UP/YES or DOWN/NO button to scroll through the choices of target gas. Table 6 below lists the choices of target gas for the M2A.

Table 6: Gas Types

Gas Type Choices	Detection Range
H2S	0 - 100 ppm
CO	0 - 300 ppm
CO	0 - 200 ppm
CO	0 - 100 ppm
CL2	0 - 3.00 ppm
CL2	0 - 10.0 ppm
NH3	0 - 75.0 ppm

Table 6: Gas Types

Gas Type Choices	Detection Range
SO2	0 - 6.00 ppm
ASH3	0 - 1.50 ppm
H2S	0 - 50.0 ppm
CLO2	0 - 1.00 ppm
CLO2	0 - 3.00 ppm
NH3	0 - 500 ppm
NH3	0 - 200 ppm
HCN	0 - 15.0 ppm
CLO2	0 - 5.00 ppm
CL2	0 - 5.00 ppm
NH3	0 - 100 ppm
PH3	0 - 1.00 ppm
SIH4	0 - 15.0 ppm
OXYGEN	0 - 25.0% volume

4. When the desired target gas is on the display, press and release the ENTER button. The display will ask **SAVE IT? YES/NO**.
5. To discard the gas type change, press and release the DOWN/NO button. The display will ask **DO OVER? YES/NO**. Press the DOWN/NO button. The display will ask **ABORT? YES/NO**. Press the UP/YES button. The M2A will return to normal operation without changing the gas type.

To save the gas type, press and release the UP/YES button. The display will indicate **Gas Type Updated**, the display will indicate the target gas and the detection range for a few seconds, and then the M2A will enter Configuration Mode automatically so that the parameter settings in Configuration Mode can be verified or changed.

6. While in Configuration Mode press and release the ENTER button to accept the displayed parameter setting and move to the next one. Use the UP/YES and DOWN/NO buttons to adjust a setting. See “Chapter 5: Configuration Mode” on page 29 for a complete description of Configuration Mode.
7. When you have reviewed and accepted the last item in Configuration Mode by pressing the ENTER button, display will ask **SAVE IT? YES/NO**.
8. To save the configuration settings, press and release the UP/YES button. The display will indicate **Config Saved** and the M2A will begin its warm-up sequence.

To discard the settings and review them again, press the DOWN/NO button. The display will ask **DO OVER? YES/NO**. Press the UP/YES button and the display will indicate **Re-do Config**, then display the target gas and the detection range for a few seconds before returning to Configuration Mode. Repeat steps 6 - 8 until the settings are as desired.

9. After the M2A completes its warm-up sequence, the display will indicate **CAL NEEDED**. Since the gas type has been changed, a successful calibration must be performed before the M2A can enter normal operation.
10. Press and release the UP/YES button to enter Calibration Mode. Normally, you must hold the UP/YES button for 5 seconds to enter Calibration Mode, but since a calibration is required, only a momentary push is needed to enter Calibration Mode after changing the gas type.
11. See “Calibration” on page 38 for calibration instructions.

NOTE: When calibrating an M2A after changing the gas type, the M2A will not ask if you want to calibrate, or whether you want to perform a fresh air adjustment, span adjustment or zero adjustment. Since a complete calibration is required, the calibration sequence will proceed without asking if you want to perform certain operations.

Chapter 7: Maintenance

Overview

This chapter describes procedures for performing preventive maintenance, troubleshooting, calibrating the M2A, and replacing field replaceable parts.

Preventive Maintenance

This section describes a recommended preventive maintenance schedule to ensure the optimum performance of the M2A. It includes daily and quarterly procedures.

Daily

Verify a display reading of 0 ppm. Investigate significant changes in the reading.

Quarterly

Calibrate the M2A as described in “Calibration” on page 38. See “Calibration Frequency” on page 37 for a discussion of calibration frequency guidelines.

Troubleshooting

The troubleshooting guide describes symptoms, probable causes, and recommended action for problems you may encounter with the M2A.

NOTE: This troubleshooting guide describes M2A problems only. If the M2A is connected to a controller, see the controller operator’s manual for problems you may encounter with the controller.

Table 7: Troubleshooting the Detector

Condition	Symptom(s)	Probable Causes	Recommended Action
No Power	The display backlight is off and the display screen is blank.	<ul style="list-style-type: none">The power wiring is disconnected or misconnected.The display cable is disconnected or misconnected.	<ol style="list-style-type: none">Verify that the wiring to the power source or controller is correct and secure.Verify that the ribbon cable connecting the terminal PCB to the control PCB is securely installed. This ribbon cable plugs into a connector on the top edge of the control PCB and on the bottom of the terminal PCB.If the power difficulties continue, contact RKI for further instruction.

Table 7: Troubleshooting the Detector

Condition	Symptom(s)	Probable Causes	Recommended Action
Frequent or Suspect Alarms	The M2A alerts you to frequent or suspect alarms while the fresh air readings remain on zero.	<ul style="list-style-type: none"> • The M2A is experiencing false readings due to RFI or EMI. • The detector wiring is disconnected, misconnected, or intermittent. 	<ol style="list-style-type: none"> 1. Verify that the M2A wiring is properly shielded. See “Wiring the M2A Transmitter” on page 18. 2. Verify that the detector wiring is correct and secure. 3. Increase the alarm on delay setting in Configuration Mode. 4. If the frequent or suspect alarm difficulties continue, contact RKI for further instruction.
Flickering Display	The display reading flickers often.	<ul style="list-style-type: none"> • The M2A is experiencing false readings due to RFI or EMI. • The noise filter setting is too low. • The zero suppression setting is too low. • The display screen is malfunctioning. 	<ol style="list-style-type: none"> 1. Verify that the M2A wiring is properly shielded. See “Wiring the M2A Transmitter” on page 18. 2. Verify that the detector wiring is correct and secure. 3. Increase the filter setting in Configuration Mode. 4. Increase the zero suppression setting in Configuration Mode. 5. If the display difficulties continue, contact RKI for further instruction.
Fail Condition	<ul style="list-style-type: none"> • M2A indicates a fail condition. • Controller indicates a fail condition 	<ul style="list-style-type: none"> • The detector wiring to the terminal PCB is disconnected or misconnected. • The wiring from the M2A to the controller is disconnected or misconnected. • The detector fresh air signal is low enough to cause a fail condition. • The detector is malfunctioning. • The terminal or display PCB is malfunctioning. 	<ol style="list-style-type: none"> 1. Verify that the detector wiring is correct and secure. 2. Verify that the wiring between the M2A and the controller is correct and secure. 3. Calibrate the M2A. 4. If the fail condition continues, replace the detector. 5. If the fail condition continues, contact RKI for further instruction.

Table 7: Troubleshooting the Detector

Condition	Symptom(s)	Probable Causes	Recommended Action
Slow or No Response/ Difficult or Unable to Calibrate	<ul style="list-style-type: none"> Unable to successfully set the fresh air or span reading during calibration. M2A requires frequent calibration. <p><i>Note: See “Calibration Frequency” on page 37 for calibration frequency guidelines.</i></p>	<ul style="list-style-type: none"> The calibration cylinder is low, out-dated, or defective. The calibration gas flow rate is too low. The calibration gas is not an appropriate concentration. The detector is malfunctioning. The terminal PCB is malfunctioning. The flexible tubing to the calibration adapter/splash guard has become kinked, blocked, or disconnected. 	<ol style="list-style-type: none"> Verify that the calibration cylinder contains an adequate supply of a fresh test sample. Verify that the regulator used for calibration is a 0.5 LPM regulator. Verify that the calibration gas concentration is appropriate for the transmitter. The concentration should be in the detection range, preferably about half of the detection range. Verify that the flexible tubing to the calibration adapter/splash guard is clear and connected to the calibration adapter/splash guard. If the calibration/response difficulties continue, replace the detector. If the calibration/response difficulties continue, contact RKI for further instruction.

Calibration Frequency

Although there is no particular calibration frequency that is correct for all applications, a calibration frequency of every 3 to 6 months is adequate for most transmitter applications. Unless experience in a particular application dictates otherwise, RKI Instruments, Inc. recommends a calibration frequency of every 3 months.

If an application is not very demanding, for example detection in a clean, temperature controlled environment where the target gas is not normally present and calibration adjustments are minimal at calibration, then a calibration frequency of every 6 months is adequate.

If an application is very demanding, for example if the target gas is present often and in significant concentrations or the environment is not well controlled, then more frequent calibration than every 3 months may be necessary.

Determining Response Time

Since the detector junction box is installed remotely from the M2A, the response time of the detector will depend on the length of flexible tubing that is attached to the calibration adapter/splash guard. To determine the response time based on the length of tubing connected:

- Place the M2A into its calibration mode or disable external alarms.
- Note the current gas reading displayed at the M2A.
- Screw the regulator into the calibration cylinder. Do not use a zero air cylinder for this operation.
- Use the flexible tubing coming from the calibration adapter/splash guard to connect the regulator to the calibration adapter/splash guard.
- Turn the regulator’s on/off knob counterclockwise to open the regulator. Gas will begin to flow. Take note of the time or start a stopwatch.

6. When you first start to notice an increase in the gas reading, note how much time passed between starting the gas flow and noticing a reading response.
7. Turn the regulator's on/off knob clockwise to close the regulator.
8. Unscrew the regulator from the calibration cylinder.
9. Disconnect the calibration adapter/splash guard's flexible tubing from the regulator.

NOTE: Do not disconnect the flexible tubing from the calibration adapter/splash guard.

10. Add 1 minute to the length of time determined in step 6. This is the response time for the detector. When performing a zero adjustment or span adjustment, gas must be applied for this length of time.

Calibration

This section describes how to calibrate the M2A transmitter. It includes procedures to prepare for calibration, enter Calibration Mode, adjust the fresh air (zero) setting, adjust the span setting, and return to normal operation.

WARNING: *The M2A is not an active gas monitoring device during the calibration procedure. The 4-20 mA output signal will “freeze” at 3.5 mA and all relays will remain in their non-alarm state while the M2A is in Calibration Mode. The output signal will not indicate current readings and the relays will not resume operating normally until the M2A is in normal operation again.*

NOTE: The detector must be calibrated with a gas concentration between 10% and 100% of the channel's full scale value (ie. a 0 - 500 ppm NH₃ detector must be calibrated with an NH₃ concentration between 50 ppm and 500 ppm).

NOTE: While in the calibration program, if there is no switch activity for the calibration time-out period the unit will return to normal operation. See “Viewing & Changing M2A Parameters” on page 29 for instructions to set the calibration time-out.

Special Note About Calibrating a ClO₂ Detector

RKI Instruments, Inc. recommends using a ClO₂ generator to set the ClO₂ detector's response reading. The flow rate on the generator needs to be set to 0.5 LPM and RKI Instruments, Inc. recommends that 0.5 ppm ClO₂ be used. If a ClO₂ generator is used for calibration, the steps related to the use of a calibration gas cylinder in the instructions below can be disregarded.

Non-Intrusive Calibration

If the M2A is installed in a classified area and non-intrusive calibration is required, follow the instructions below, but do not remove the junction box cover. Use the magnetic wand accessory to actuate the magnetic switches instead of pushing the control switch buttons. To actuate a magnetic switch and perform the same operation as pressing a control switch button, touch the magnet in the end of the magnetic wand to the M2A's glass cover directly above the magnetic switch you wish to actuate.

Touching the glass and removing the wand is the same as pressing and releasing a button. Touching the glass and keeping the wand in place is the same as pressing and holding a button.

Calibration Gas Response Memory Feature

The M2A has the capability to “remember” the detector’s response to the calibration gas after the gas is removed from the detector during the fresh air and span adjustment procedure. This feature enables one person to perform a calibration if the detector is mounted remotely from the M2A. When zero air is applied to the M2A during a fresh air adjustment, the M2A freezes the display reading at the lowest response and the M2A continues to display this reading and retain it in its memory until the fresh air adjustment procedure is completed. When calibration gas is applied to the M2A during a span adjustment, the M2A freezes the display reading at the highest response to the calibration gas. The calibration gas can then be removed and the M2A will continue to display this reading and retain it in its memory until the span adjustment procedure is completed.

Materials

- **0.25 LPM** fixed flow regulator

CAUTION: *Using the 0.5 LPM regulator that is normally recommended for M2As will result in an inaccurate calibration.*

- zero air cylinder (if you suspect the presence of the target gas in the sampling environment)
- calibration gas cylinder containing a known concentration of the target gas

NOTE: The detector must be calibrated with a gas concentration between 10% and 100% of the channel’s full scale value (ie. a 0 - 500 ppm NH₃ detector must be calibrated with an NH₃ concentration between 50 ppm and 500 ppm).

Adjusting the Fresh Air Reading

CAUTION: *For all gases except ClO₂: Confirm that the detector has been running for 15 minutes before performing a calibration.*

For ClO₂: Confirm that the detector has been running for 2-3 hours before performing a calibration.

1. While in normal operation, press and hold the UP/YES button for 5 seconds to enter Calibration Mode. Release the button when the following screen appears.

Calib?
YES/NO

2. If you want to continue with calibration, press and release the UP/YES button. The display will indicate the target gas and **CAL Mode** for a few seconds before showing **FreshAir Adjust?**.

If you want to exit Calibration Mode, press and release the DOWN/NO button. The M2A will indicate **Leaving CAL Mode** and the M2A will return to normal operation.

3. To continue with adjusting the fresh air reading, press and release the UP/YES button. **ENTER** will alternate with **FreshAir** on the top display line and the current gas reading will be on the bottom display line.

To skip adjusting the fresh air reading, press and release the DOWN/NO button. The display will indicate **SPAN w/Cal Gas?**. Skip to the next section, “Adjusting the Span Setting”.

4. Screw the zero air cylinder into the **0.25 LPM** fixed flow regulator.

CAUTION: *Using the 0.5 LPM regulator that is normally recommended for M2As will result in an inaccurate calibration.*

5. Use the flexible tubing coming from the calibration adapter/splash guard to connect the regulator to the calibration adapter.
6. Turn the regulator knob counterclockwise to open the regulator.
7. Allow zero air to flow for the length of time determined in “Determining Response Time” on page 37.
8. Turn the regulator knob clockwise to close the regulator.
9. Unscrew the zero air cylinder from the fixed flow regulator. Leave the calibration adapter/splash guard’s flexible tubing connected to the regulator. The M2A will continue to display the minimum gas response on the display and retain the response level in its memory.
10. Press and release the ENTER button. The M2A will perform a fresh air adjustment and the display will indicate **SPAN w/Cal Gas?**.

NOTE: If the fresh air adjustment fails, see “Troubleshooting” on page 35 for recommended actions.

Adjusting the Span Setting

1. If you want to continue with adjusting the span setting, press and release the UP/YES button. **APPLY** will alternate with **SPAN Gas** on the top display line and the current gas reading will be on the bottom display line.

If you want to skip adjusting the span reading, press and release the DOWN/NO button. The display will indicate **Leaving Cal Mode** and the M2A will return to normal operation.

2. It is important to vent the regulator while installing it onto the cylinder. Venting the regulator during installation helps prevent air from getting into the cylinder and degrading the gas. Open the **0.25 LPM** regulator by turning the knob counterclockwise.
3. Install the **0.25 LPM** regulator onto the cylinder.

CAUTION: *Using the 0.5 LPM regulator that is normally recommended for M2As will result in an inaccurate calibration.*

4. Allow calibration gas to flow for the length of time determined in “Determining Response Time” on page 37.
5. Turn the regulator knob clockwise to close it.

6. Unscrew the calibration gas cylinder from the fixed flow regulator. The M2A will continue to display the maximum gas response on the display and retain the response level in its memory.
7. **Adjust the gas reading up or down to match the calibration gas cylinder concentration by using the UP/YES and DOWN/NO buttons, then press and release the ENTER button.**

NOTE: The detector must be calibrated with a gas concentration between 10% and 100% of the channel's full scale value (ie. a 0 - 500 ppm NH₃ detector must be calibrated with an NH₃ concentration between 50 ppm and 500 ppm).

8. The M2A will perform a span operation. The display will indicate **SPAN Gas PASS** for a few seconds, then indicate **SPAN Gas SAVED** before indicating **Leaving CAL Mode** for a few seconds.

NOTE: If the span adjustment fails, see "Troubleshooting" on page 35 for recommended actions.

9. The display will now alternate between the normal operation screen and the message **REMOVE CAL GAS** for 1 minute. If the calibration gas has not been removed from the detector, remove it now to avoid unwanted alarms.

During this 1 minute period, the signal output will remain fixed at 3.5 mA and the relays will remain in their non-alarm state to avoid unwanted alarms while the calibration gas clears from the detector. At the end of the 1 minute period, the **REMOVE CAL GAS** message will stop appearing and the M2A will return to normal operation.

10. Disconnect the calibration adapter/splash guard's flexible tubing from the regulator.

NOTE: Do not disconnect the flexible tubing from the calibration adapter/splash guard.

11. Store the components of the calibration kit in a safe place.

Replacing Components of the Detector

This section includes a procedure to replace the plug-in sensor, the hydrophobic membrane, and the entire detector assembly. In most cases, it is not necessary to replace the entire detector assembly.

Replacing the Plug-In CO Sensor

CAUTION: *The sensor contains electrolyte which is a dilute acid. Do not disassemble the sensor when replacing it with a new one. If sensor electrolyte comes in contact with your skin, wash affected area thoroughly with soap and water.*

1. Turn off or unplug power to the M2A.
2. Unscrew the calibration adapter/splash guard from the detector housing cap.
3. Unscrew the detector housing cap from the detector housing body. Make sure not to lose the cap gasket.
4. Unplug and remove the CO sensor with the rubber boot and charcoal filter attached.
5. Remove the rubber boot and charcoal filter from the old sensor.

6. Remove the replacement sensor from its packaging and remove the wire jumper. This wire jumper is installed on the sensor pins for shipment or storage but must be removed for the sensor to operate properly when installed in a detector.

WARNING: *The sensor will not operate properly if the wire jumper is not removed.*

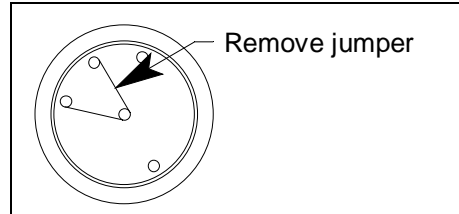

Figure 10: Plug-In Sensor Jumper Removal

7. Install the rubber boot and charcoal filter onto the new sensor's face.
8. Carefully plug the replacement sensor into the four-socket pattern that is located in the detector housing.
9. Make sure the cap gasket is in place and screw the detector housing cap back onto the detector housing body.
10. Screw the calibration adapter/splash guard back onto the detector housing cap.
11. Turn on or plug in power to the M2A.

CAUTION: *For all gases except ClO₂: Allow the replacement sensor to warm up for 15 minutes before you continue with the next step.*

For ClO₂: Allow the replacement sensor to warm up for 2-3 hours before you continue with the next step.

12. Calibrate the transmitter as described in the "Calibration" on page 38.

Replacing the Hydrophobic Membrane

1. Turn off or disconnect power to the M2A.
2. Unscrew the detector housing cap from the detector housing body.
3. Unplug the plug-in sensor from the four-socket pattern in the detector housing body.
4. Gently pry up the edge of the white hydrophobic membrane from the sensor face with a small flat blade screwdriver or a similar tool.
5. Peel off the hydrophobic membrane. It may be necessary to clean off the sensor face to remove any residue left from the adhesive backed membrane.
6. Install the new membrane on the face of the plug-in sensor.
7. Plug the sensor back into the four-socket pattern in the detector housing body.
8. Make sure the cap gasket is in place and screw the detector housing cap back onto the detector housing body.
9. Turn on or reconnect power to the M2A.

Replacing the Detector

NOTE: In most cases, it is only necessary to replace the plug-in sensor.

1. Turn off or unplug power to the M2A.
 2. Remove the detector junction box cover.
 3. Unscrew the calibration adapter/splash guard from the detector housing cap.
 4. Disconnect the detector leads from the terminal block in the detector junction box. Note the position of the color-coded leads as you remove them.
 5. Unscrew the detector from the detector junction box.
 6. Guide the detector leads of the replacement detector through the bottom conduit hub of the detector junction box, then screw the mounting threads of the detector into the conduit hub. If necessary for environmental conditions, apply thread sealant or Teflon tape to the hub and/or detector threads to seal them.
 7. Connect the detector leads to the terminal block the same way the old detector was wired (see Figure 8 on page 19).
 8. Screw the calibration adapter/splash guard onto the new detector housing cap.
 9. Reinstall the detector junction box cover.
 10. Turn on or plug in power to the M2A.
-

CAUTION: *For all gases except ClO₂: Allow the replacement detector to warm up for 15 minutes before you continue with the next step.*

For ClO₂: Allow the replacement detector to warm up for 2-3 hours before you continue with the next step.

11. Calibrate the replacement detector as described in “Calibration” on page 38.

Chapter 8: RS-485 Modbus Output

Overview

This chapter describes the M2A's RS-485 Modbus output and how to configure the M2A to make use of it. It also discusses how to wire the M2A into a Modbus system.

The M2A provides an RS-485 serial communications interface. It is a Modbus Slave Device, supporting 2-wire RS-485 Modbus RTU serial communications.

Wiring the M2A in a Modbus System

The M2A is a 2-wire Modbus RTU device. When wiring the M2A into a Modbus system, adhere to standard Modbus wiring practices per the Modbus Over Serial Line Specification and Implementation Guide V1.0 or later. This document can be found online at www.modbus.org/specs.php.

The Modbus protocol supports a maximum of 247 unique slave addresses (1-247). The M2A's line driver provides for up to 128 M2As to be connected together without the need for a repeater. Figure 13 & Figure 14 below illustrate typical M2A wiring configurations. If more than 128 M2As need to be connected together, RS-485 repeater(s) should be used such that no more than 128 M2As reside on any given network segment.

CAUTION: *The network segment can only support 128 units if RKI M2As are being used. The use of any other instruments will lower the number of units that may reside on any given network segment.*

NOTE: Only M2As produced after November 2010 have the capability to support a 128-unit segment. M2As produced before November 2010 can only support a 32-unit segment.

The MODBUS terminal strip is located on the terminal PCB (see Figure 4 on page 13). The following signals are available at the Modbus terminal strip:

Table 8: Modbus Terminal Strip Signals

Modbus Terminal Label (RS-485 Name)	Modbus Signal Name
A	D0
B	D1
C	Common

Ground Jumper

The M2A includes a 2-pin ground header (see Figure 4 on page 13) that is used when the M2A is used in a Modbus system. Every M2A is supplied with a ground jumper (a jumper block) installed onto this header. If the M2A isn't wired into a Modbus system or if it is wired into one as shown in Figure 12, the ground jumper should be installed. If the M2A is wired in a Modbus system as shown in Figure 11, the ground jumper should be removed.

Recommended Modbus Wiring

The recommended Modbus wiring for the M2A is illustrated in Figure 11 below. In this configuration, 5 wires are used for wiring the M2A into a Modbus system. Figure 11 also illustrates typical alarm device wiring. The ground jumper must be removed in this wiring configuration.

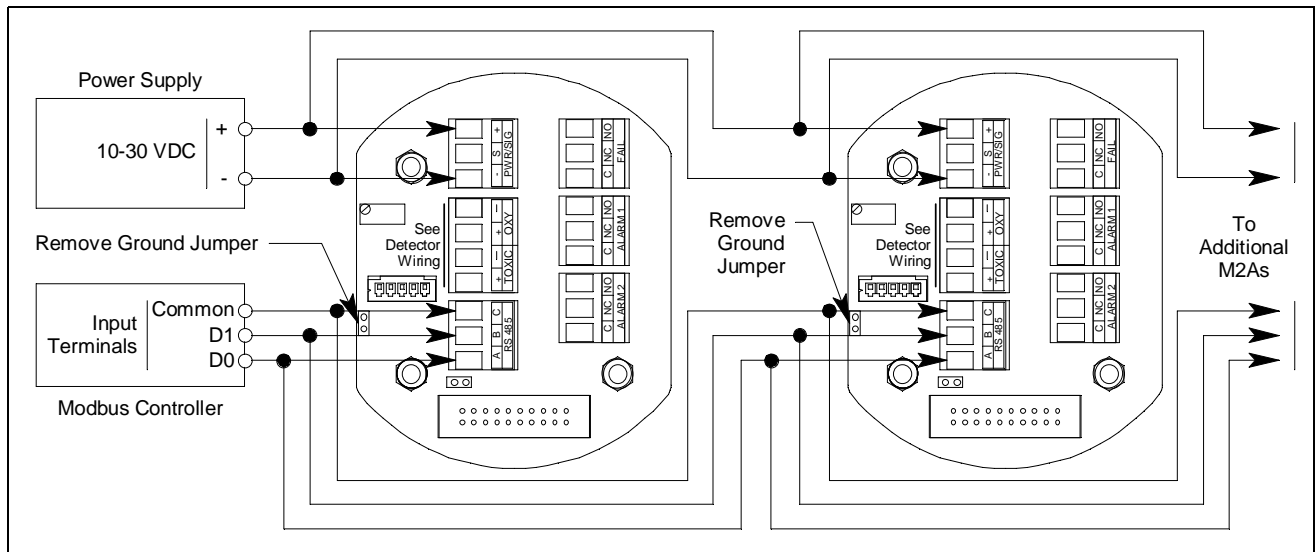

Figure 11: Recommended Modbus Wiring

Adding an M2A to an Existing M2 Modbus Installation with Recommended Wiring

An M2A can be wired into an existing M2 Modbus system. The shape of the terminal PCB will be different but the wiring connections are identical and the ground jumper on the M2A must still be removed.

Alternate Modbus Wiring For Existing Installations

Although the wiring shown in Figure 11 is recommended, it is possible to wire the M2A into a Modbus system with only 4 wires in situations where a pre-existing system is being replaced and wiring is already in place. This should only be done if wiring for a system that is being replaced is already installed and it is not practical to run another wire. See Figure 12 below for this wiring configuration. In this configuration, the wire between the “C” terminal on the M2A and the Common terminal on the Modbus controller is omitted. Instead, the Common terminal on the Modbus controller is connected to the “-” of the 24 VDC power supply. The ground jumper must be installed in this wiring configuration.

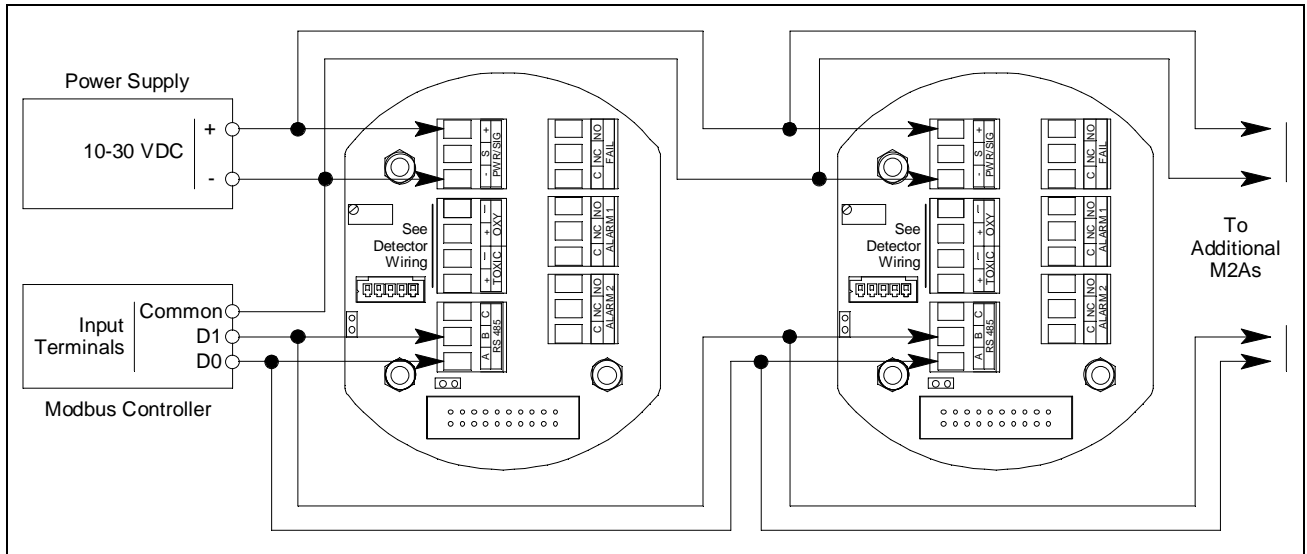

Figure 12: Alternate Modbus Wiring

Adding an M2A to an Existing M2 Modbus Installation with Alternate Wiring

An M2A can be wired into an existing M2 Modbus system. The shape of the terminal PCB will be different but the wiring connections are identical and the ground jumper on the M2A must still remain installed.

Termination Jumper

The M2A includes a 2-pin termination header (see Figure 4 on page 13) that is used when the M2A is used in a Modbus system. Every M2A is supplied with a termination jumper (a jumper block) installed onto this header. If the M2A is not used in a Modbus system, this jumper has no function. When the M2A is installed in a Modbus system, this jumper must be installed in an M2A that is at the end of a Modbus line. Any M2A in a Modbus system that is not at the end of a line must have the termination jumper removed (see Figure 13 & Figure 14 below).

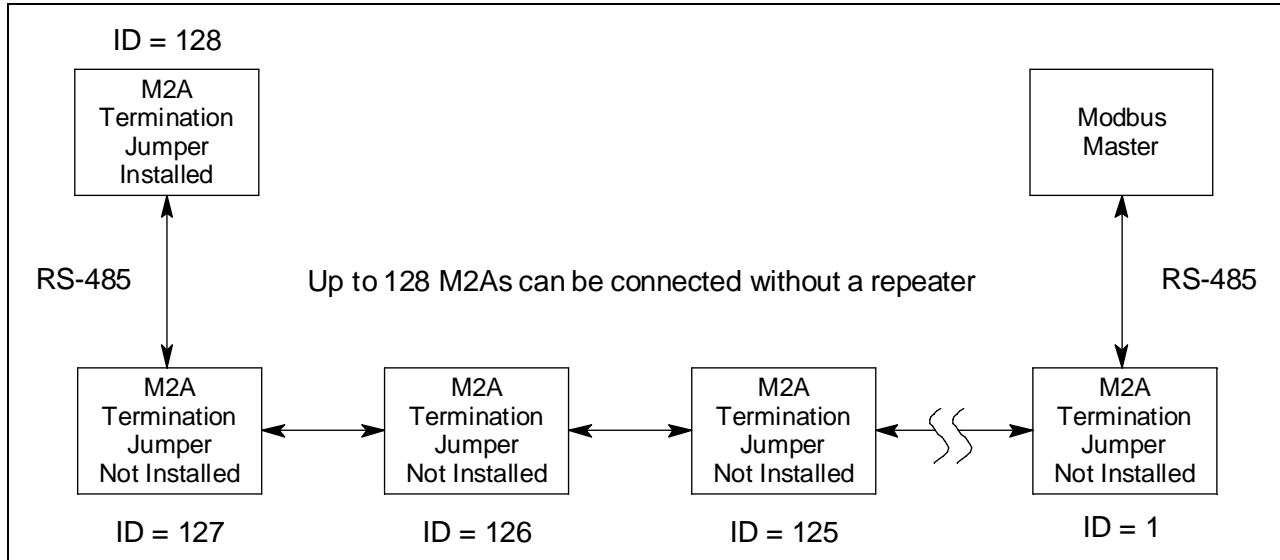

Figure 13: Multiple M2As in a Daisy Chain Configuration

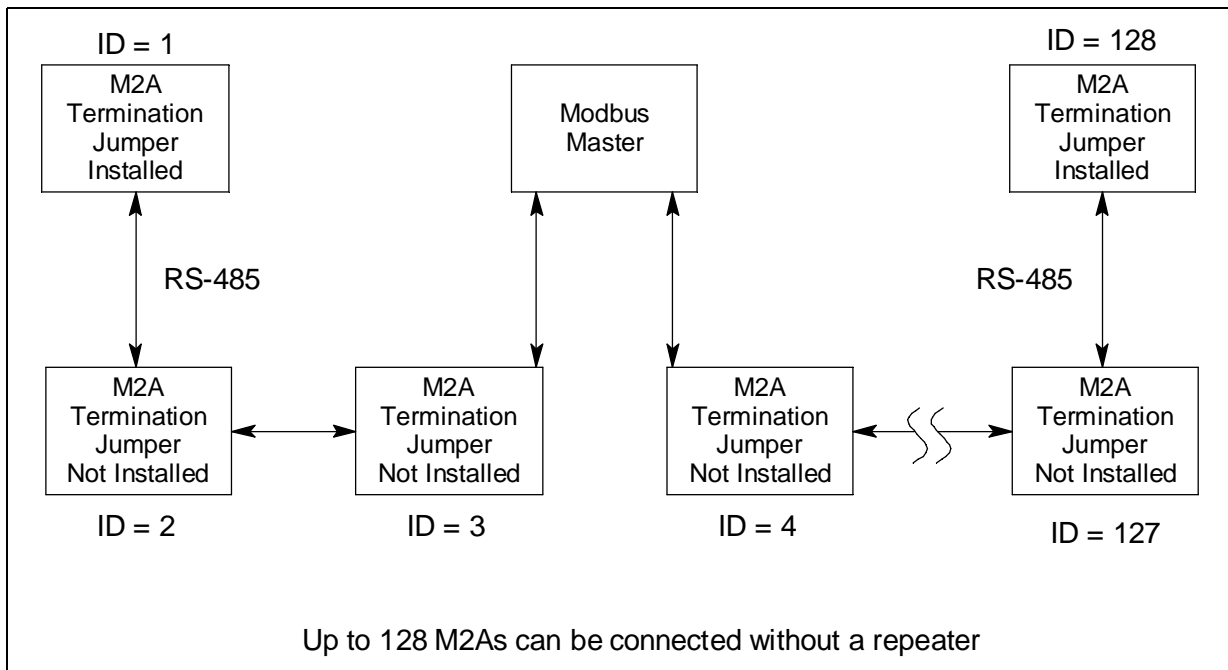

Figure 14: Multiple M2As in a Two-Branch Configuration

Using the M2A in a 4-wire Modbus System

Although the M2A is a 2-wire Modbus RTU device, it can be used with a 4-wire Modbus controller if the system wiring is modified as follows:

- Connect the controller's TxD0 and RxD0 wires together and use this connection as the 2-wire Modbus D0 signal.
- Connect the controller's TxD1 and RxD1 wires together and use this connection as the 2-wire Modbus D1 signal.
- Connect these D0 and D1 signals and the common wire from the controller to the 2-wire Modbus Network of M2As.

Modbus Mode

Modbus Mode allows you to configure various parameters relating to the Modbus setup of the M2A. Modbus Mode includes a 5-minute time-out feature. If you do not press a control button for 5 minutes, the M2A automatically returns to normal operation.

NOTE: If the M2A returns to normal operation because of a time-out, it enters a warm-up period just as it does when it is first turned on.

1. While in normal operation, simultaneously press and hold the DOWN/NO and ENTER buttons for 5 seconds to enter Modbus Mode. Release the buttons when the following screen appears.

Set Up
Modbus?

2. To exit Modbus Mode, press and release the DOWN/NO button. The M2A will return to normal operation.
To continue in Modbus Mode, press and release the UP/YES button. The current ENABLED/DISABLED setting will appear.
3. If you want to change the currently displayed parameter, use the UP/YES and DOWN/NO buttons to adjust it to the desired setting, then press ENTER to continue to the next parameter.

If the currently displayed parameter setting is OK, press the ENTER button to proceed to the next parameter.

Table 9 lists the M2A Modbus Mode parameters you can set. Table 9 also lists the factory set value for each parameter.

Table 9: Configuration Parameters

Modbus Mode Parameter	Available Settings & Description
Enabled/Disabled	Can be set to ENABLED or DISABLED (factory setting). Enables or disables the Modbus output.
Slave ID	The Slave ID can be set to values from 1 (factory setting) to 247. The M2A will only receive messages from the Master which are addressed to this Slave ID (except for broadcast messages which are received by all slaves).
Baud Rate	Can be set to 1200, 2400, 4800, 9600 (factory setting), 14440, & 19200.
Parity	EVEN (factory setting), ODD, NONE
Response Delay	The response delay can be set from 0 (factory setting) to 20 mS. This is an optional additional delay inserted by the M2A prior to returning a response message to the Master. It may be helpful in some installations where the Master's preparedness to receive responses might be delayed.

4. When you have scrolled through all the adjustable parameters, **SAVE IT? YES/NO** appears on the display.
5. If you do not wish to save the adjustments, press and release the DOWN/NO button. The **DO OVER? YES/NO** message will display. Press and release the DOWN/NO button. The **ABORT? YES/NO** message will display. Press the UP/YES button to return to normal operation.

If you wish to change some of the adjustments made, press and release the DOWN/NO button. The **DO OVER? YES/NO** message will display. Press and release the UP/YES button. The **Re-do MB Setup** message will display and the M2A will return to the first adjustable parameter. Go back to step 3 and continue.

If you want to save the adjustments made, press and release the UP/YES button. **Modbus Saved** is indicated on the display for a few seconds and the M2A returns to normal operation.

NOTE: All M2As on a Modbus network must be configured with the same baud rate and parity, and each M2A must have a unique slave ID. For an M2A to participate on a network, the ENABLED/DISABLED setting must be set to ENABLE.

Supported Modbus Functions

The M2A supports Function Code 03: Read Holding Registers and Function Code 16: Write Registers.

Function Code 03: Read Holding Registers

There are a total of 40 registers available to be read via this Function Code.

Registers 1 - 2

The format (bit & field assignments) for registers 1 - 2 is shown below in Table 10 - Table 11.

Table 10: Register 1, Numerical Reading with Sign & Decimal Point Bit & Field Assignments

Bit(s)	Value & Field
[15]	<u>Sign of Reading</u> 0 = Positive 1 = Negative
[14:13]	<u>Format of Reading</u> 0 = XXX (no decimal point) 1 = XX.X 2 = X.XX 3 = .XXX
[12:0]	Numerical value of display reading (8000 max)

Table 11: Register 2, Operating State, Alarms & Relays Bit & Field Assignments

Bit(s)	Value
[15:12]	<u>Operating State</u> 0 = Undefined 1 = Initialization 2 = Normal 3 = Warm-up 4 = Fail 5 = Calibration 6 = Post-Calibration 7 = Low Power 8 = Setup
[11]	<u>Gas Type Change</u> 0=Not Changed 1=Changed
[10]	<u>Configuration Change</u> 0=Not Changed 1=Changed
[9]	<u>Calibration Activity Flag</u> 0=No Calibration Activity 1=Calibration Activity Has Occurred

Table 11: Register 2, Operating State, Alarms & Relays Bit & Field Assignments (Continued)

Bit(s)	Value
[8]	<u>Fail Status</u> 0 = Fail Not Asserted 1 = Fail Asserted
[7:6]	<u>Alarm 2 Status</u> 0 = No Alarm 1 = Unacknowledged Alarm 2 = Acknowledged Alarm 3 = Unused Code
[5:4]	<u>Alarm 1 Status</u> 0 = No Alarm 1 = Unacknowledged Alarm 2 = Acknowledged Alarm 3 = Unused Code
[3]	<u>Overscale Status</u> 0 = Not Overscale 1 = Overscale
[2]	<u>Fail Relay Status</u> 0 = Not Energized 1 = Energized
[1]	<u>Alarm 2 Relay Status</u> 0 = Not Energized 1 = Energized
[0]	<u>Alarm 1 Relay Status</u> 0 = Not Energized 1 = Energized

Register 3

Register 3 is the supply voltage (0.1 volt per count).

Registers 4 - 11

The 16 bytes in these registers contain the same ASCII text information that is displayed on the M2A's OLED display (not NULL Terminated).

Register 12

Register 12 is the range (full scale readout).

Register 13

Register 13 is the alarm 1 set point.

The decimal point location is the same as specified in Register 1.

Register 14

Register 14 is the alarm 2 set point.

The decimal point location is the same as specified in Register 1.

Registers 15 - 19

Registers 15 - 19 are the Gas Name ASCII String (NULL Terminated).

Registers 20 - 22

Registers 20 - 22 are the Gas Units String (NULL Terminated).

Register 23

Register 23 is the alarm 1 trigger.

0=Decreasing

1=Increasing

Register 24

Register 24 is the alarm 1 normal relay state.

0=Normally De-Energized

1=Normally Energized

Register 25

Register 25 is the alarm 1 relay reset.

0=Latching

1=Self-Resetting

Register 26

Register 26 is the alarm 1 ON delay.

Integer values are in seconds.

Register 27

Register 27 is the alarm 1 OFF delay.

Integer values are in seconds.

Register 28

Register 28 is the alarm 2 trigger.

0=Decreasing

1=Increasing

Register 29

Register 29 is the alarm 2 normal relay state.

0=Normally De-Energized

1=Normally Energized

Register 30

Register 30 is the alarm 2 relay reset.

0=Latching

1=Self-Resetting

Register 31

Register 31 is the alarm 2 ON delay.

Integer values are in seconds.

Register 32

Register 32 is the alarm 2 OFF delay.
Integer values are in seconds.

Register 33

Register 33 is zero suppression.
Toxics and LEL: 0%-6% of full scale
Oxygen: 0%-0.7% Oxygen
The decimal point location is the same as specified in Register 1.

Register 34

Register 34 is noise filter.
Integer values in seconds.
0-60 in 5 second increments.

Register 35

Register 35 is calibration timeout in minutes (5, 10, 15, 20, 25, or 30).

Register 36

Register 36 is calibration month (upper byte) and day (lower byte).
This is zero based (e.g. January=0 and the 1st=0).

Register 37

Register 37 is the calibration year.

Register 38

Register 38 is the calibration outcome.
Upper=Gas Operation
Lower=Air Operation

Calibration Outcome Codes:

- 1=Sensor Missing
- 2=Sensor Too Weak
- 3=Signal Too Strong
- 4=Not Enough Span
- 5=Negative Reading
- 6=Span Gas Value Is Not OK
- 7=Calculated Zero Is Too Low
- 8=Calculated Zero Is Too High
- 9=Zero Failure
- 10=Span Failure
- 11=Calibration Is Overscale
- 12=LEL Sensor Offset Is Too High
- 13=LEL Null Operation Failed
- 14=Operation Not Performed

Register 39

Register 39 is the auto-zero disable.
0=AutoZero Enabled
1=AutoZero Disabled

Register 40

Register 40 is the remote configuration register access level

0=None

1=Alarm Reset

Function Code 16: Write Registers

There are 21 registers in Function Code 16 that can be used to write to the M2A. This section only describes Register 16 because it can be used to reset an alarm condition. For a complete description of Function Code 16, see “Appendix C: Function Code 16 Registers” on page 60.

Register 16

Register 16 performs the same function as the ENTER button on the M2A. It is useful for remotely silencing alarms. With the M2A in an alarm condition, bit [0] can be used to silence it.

NOTE: Register 40 in Function Code 03, the remote configuration register, must be set to 1 in order for Register 16 to work.

Table 12: Register 16, Button Function

Bit	Value & Field
[0]	ENTER (used for “Alarm Reset”) 0=Not Pressed 1=Pressed

Chapter 9: Parts List

Table 13 lists replacement parts and accessories for the M2A Transmitter.

Table 13: Parts List

Part Number	Description
06-1248RK	Calibration kit sample tubing (3/16 in. x 5/16 in.; specify length when ordering), for connecting Teflon tubing to the calibration adapter/splash guard and to the regulator during calibration
06-1273RK	Teflon tubing (1/8 in. x 1/4 in.; specify length when ordering), for routing to an accessible area
07-0039RK	Detector housing cap gasket
18-0400RK-01	Detector junction box, with spacers
18-0431-01-01	M2A junction box with foam pad, label, and conduit plug
33-0157RK	Hydrophobic membrane
45-6132RK	Termination and ground jumper
65-2051-01	Plug-in sensor, 0 - 3.00 ppm, 0 - 5.00 ppm, and 0 - 10.0 ppm Cl ₂ , with membrane (for 65-2302-CL2, 65-2302-CL2-5, and 65-2302-CL2-10 detectors)
65-2052-01	Plug-in sensor, 0 - 1.00 ppm, 0 - 3.00 ppm, and 0 - 5.00 ppm ClO ₂ , with membrane (for 65-2302-CLO2, 65-2302-CLO2-3, and 65-2303-CLO2-5 detectors)
65-2053-01	CT-7 Series plug-in sensor, 0 - 500 ppm NH ₃ , with membrane (for 65-2302-NH3-500 detector)
65-2054-01	CT-7 Series plug-in sensor, 0 - 75.0 ppm, 0 - 100 ppm, and 0 - 200 ppm NH ₃ , with membrane (for 65-2302-NH3, 65-2302-NH3-1, and 65-2303-NH3-2 detectors)
65-2302-CL2	CT-7 Series detector, 0 - 3.00 ppm chlorine (includes sensor)
65-2302-CL2-5	CT-7 Series detector, 0 - 5.00 ppm chlorine (includes sensor)
65-2302-CL2-10	CT-7 Series detector, 0 - 10.0 ppm chlorine (includes sensor)
65-2302-CLO2	CT-7 Series detector, 0 - 1.00 ppm chlorine dioxide (includes sensor)
65-2302-CLO2-3	CT-7 Series detector, 0 - 3.00 ppm chlorine dioxide (includes sensor)
65-2302-CLO2-5	CT-7 Series detector, 0 - 5.00 ppm chlorine dioxide (includes sensor)
65-2302-NH3	CT-7 Series detector, 0 - 75.0 ppm ammonia (includes sensor)
65-2302-NH3-1	CT-7 Series detector, 0 - 100 ppm ammonia (includes sensor)
65-2302-NH3-2	CT-7 Series detector, 0 - 200 ppm ammonia (includes sensor)
65-2302-NH3-5	CT-7 Series detector, 0 - 500 ppm ammonia (includes sensor)
71-0518	<i>65-2670-XX-04 M2A Transmitter Operator's Manual (this document)</i>
81-0076RK-01	Zero air calibration cylinder, 34 liter steel

Table 13: Parts List

Part Number	Description
81-0076RK-03	Zero air calibration cylinder, 103 liter
81-0176RK-02	Calibration cylinder, 25 ppm NH ₃ in nitrogen, 58 liter
81-0176RK-04	Calibration cylinder, 25 ppm NH ₃ in nitrogen, 34 liter aluminum
81-0190RK-02	Calibration cylinder, 5 ppm Cl ₂ in nitrogen, 58 liter
81-0190RK-04	Calibration cylinder, 5 ppm Cl ₂ in nitrogen, 34 liter aluminum
81-0192RK-02	Calibration cylinder, 2 ppm Cl ₂ in nitrogen, 58 liter
81-0192RK-04	Calibration cylinder, 2 ppm Cl ₂ in nitrogen, 34 liter aluminum
81-1050RK-25	Regulator, fixed flow, 0.25 LPM, with gauge and knob, for 17 liter and 34 liter steel cylinders (cylinders with external threads)
81-1051RK-25	Regulator, fixed flow, 0.25 LPM, with gauge and knob, for 34 liter aluminum, 58 liter, and 103 liter cylinders (cylinders with internal threads)
81-1116RK	Calibration adapter/splash guard
81-9029RK-02	Calibration cylinder, 100 ppm NH ₃ in nitrogen, 58 liter

Appendix A: Control Button Quick Reference Guide

The M2A’s control buttons allow access to operational modes, resetting of alarms, and display of the Information Screen. Table 14 shows which button combinations perform these functions and which parameters are available for adjustment while in the operational modes. While in these modes, display prompts showing a “?” require you to respond by pressing either the UP/YES (for yes) or DOWN/NO (for no) button. To change parameter settings, use the UP/YES and DOWN/NO buttons to get the desired setting, then press and release the ENTER button to accept the setting.

Table 14: Control Button Quick Reference Chart

Mode Entered or Function Performed	Button Combination	Adjustable or Viewable Parameters
Alarm Reset	Press and Release ENTER	n/a
Show Information Screen	Press and Hold DOWN/NO	<ul style="list-style-type: none"> • Input Voltage • M2A Version/Revision Information
Calibration Mode	Press and Hold UP/YES for 5 seconds	<ul style="list-style-type: none"> • Fresh Air Adjust • Span (or Zero for Oxygen) Adjust with Calibration Gas
Configuration Mode	Press and Hold UP/YES & ENTER for 5 seconds	<ul style="list-style-type: none"> • Alarm Levels • Increasing or Decreasing Alarms • Normally Energized or Normally De-energized Relays • Latching or Self-resetting Alarms • Alarm On Delay • Alarm Off Delay (if self-resetting) • Zero Suppression • Noise Filter • Calibration Time-out Period
Gas Type Mode	Press and Hold UP/YES and DOWN/NO for 5 seconds	Gas Type
Modbus Mode	Press and Hold DOWN/NO and ENTER for 5 seconds	<ul style="list-style-type: none"> • Enable or Disable Modbus • Slave ID • Baud Rate • Parity • Response Delay

Appendix B: PLC and DCS Device Wiring

The M2A can be wired to a PLC or DCS device if desired.

1. Guide multi conductor shielded cable or cables or wires in conduit through the top conduit hub of the junction box. The number of cables or wires needed will depend on whether any relays are used and whether the Modbus output is used. Use the following recommendations to determine how to wire the M2A:
 - If Modbus connections will not be used and only the PWR/SIG terminal strip connections will be used, use four conductor shielded cable or four wires in conduit for connections to the power/signal terminal strip.

Table 15: Wire Size for PWR/SIG Connections

Max Distance to Controller w/18 Gauge Wire	Max Distance to Controller w/16 Gauge Wire	Max Distance to Controller w/14 Gauge Wire
2,500 ft.	5,000 ft.	8,000 ft.

- If the PWR/SIG terminal strip connections and one or more relays are used, route the connections to the M2A in conduit. Use shielded cable in the conduit for the PWR/SIG connections and unshielded cable or individual wires for the relay connections. Make sure any wire or cable used for relay wiring is appropriately rated for the power that it will carry.

NOTE: If shielded cable is used for the PWR/SIG connections, leave the cable shield's drain wire insulated and disconnected at the M2A. You will connect the opposite end of the cable's drain wire at the controller or device.

- If the M2A will be wired into a Modbus network, see "Chapter 8: RS-485 Modbus Output" on page 44.

See Figure 15 below for field wiring connections to the M2A.

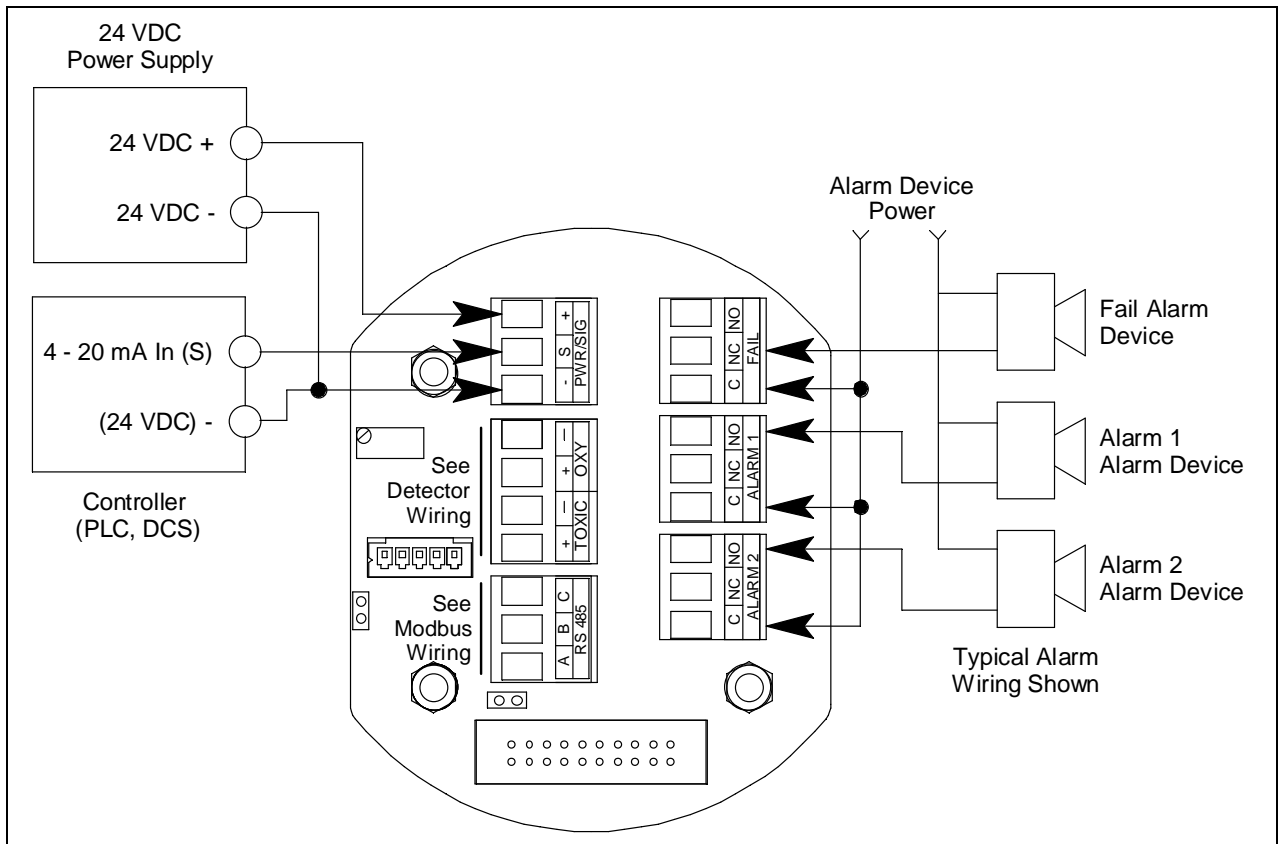

Figure 15: PLC and DCS Device Wiring

Appendix C: Function Code 16 Registers

The M2A supports Function Code 16 that allows writing to the M2A. There are 21 registers in this Function Code.

Register 1

Register 1 is the alarm 1 set point.
Value must be an integer. Any decimals are omitted.

Register 2

Register 2 is the alarm 1 trigger.
0=Decreasing
1=Increasing

Register 3

Register 3 is the alarm 1 relay state.
0=Normally De-Energized
1=Normally Energized

Register 4

Register 4 is the alarm 1 relay reset.
0=Latching
1=Self-Resetting

Register 5

Register 5 is the alarm 1 ON delay.
Integer value is in seconds.

Register 6

Register 6 is the alarm 1 OFF delay.
Integer value is in seconds.

Register 7

Register 7 is the alarm 2 set point.
Value must be an integer. Any decimals are omitted.
The decimal point location is the same as specified in Register 1 of Function Code 03.

Register 8

Register 8 is the alarm 2 trigger.
0=Decreasing
1=Increasing

Register 9

Register 9 is the alarm 2 relay state.
0=Normally De-Energized
1=Normally Energized

Register 10

Register 10 is the alarm 2 relay reset.

0=Latching

1=Self-Resetting

Register 11

Register 11 is the alarm 2 ON delay.

Integer value is in seconds.

Register 12

Register 12 is the alarm 2 OFF delay.

Integer value is in seconds.

Register 13

Register 13 is the zero suppression.

Toxics and LEL: 0%-6% Full Scale

Oxygen: 0%-0.7% Oxygen

Value must be an integer. Any decimals are omitted.

Register 14

Register 14 is the noise filter.

Integer value is in seconds (0-60 in 5 second increments).

Register 15

Register 15 is the calibration timeout.

Value is in minutes (5, 10, 15, 20, 25, or 30).

Register 16

Register 16 is explained in “Supported Modbus Functions” in the M2A manual.

Register 17

Register 17 is the calibration month (MSB) and day (LSB).

This is zero-based (e.g. January=0 and the 1st=0).

Register 18

Register 18 is the calibration year.

Register 19

Register 19 is for clearing change flags. When parameters are changed at the M2A, a flag is raised at the controller. This register can be used to clear those flags.

Table 16: Register 19, Clear Change Flags

Bit(s)	Value & Field
[15:2]	Unused
[1]	Write “1” to this bit to clear “Gas Type Changed” flag
[0]	Write “1” to this bit to clear “Configuration Changed” flag

Register 20

Register 20 is the AutoZero Disable.

0=AutoZero Enabled

1=AutoZero Disabled

Register 21

Register 21 is the Remote Configuration Register.

0=No Remote Configuration

1=Reset Alarm