



**INSTRUMENTS**

**65-2322-04SS  
Oxygen Transmitter  
Operator's Manual**

*Part Number: 71-0481*

*Revision: A*

*Released: 10/1/20*

## **WARNING**

Read and understand this instruction manual before operating detector. Improper use of the detector could result in bodily harm or death.

Periodic calibration and maintenance of the detector is essential for proper operation and correct readings. Please calibrate and maintain this detector regularly! Frequency of calibration depends upon the type of use you have and the sensor types. Typical calibration frequencies for most applications are between 3 and 6 months, but can be required more often or less often based on your usage.

---

## Product Warranty

RKI Instruments, Inc. warrants gas alarm equipment sold by us to be free from defects in materials, workmanship, and performance for a period of one year from date of shipment from RKI Instruments, Inc. Any parts found defective within that period will be repaired or replaced, at our option, free of charge. This warranty does not apply to those items which by their nature are subject to deterioration or consumption in normal service, and which must be cleaned, repaired, or replaced on a routine basis. Examples of such items are:

- a) Absorbent cartridges
- b) Pump diaphragms and valves
- c) Fuses
- d) Batteries
- e) Filter elements

Warranty is voided by abuse including mechanical damage, alteration, rough handling, or repair procedures not in accordance with the operator's manual. This warranty indicates the full extent of our liability, and we are not responsible for removal or replacement costs, local repair costs, transportation costs, or contingent expenses incurred without our prior approval.

*THIS WARRANTY IS EXPRESSLY IN LIEU OF ANY AND ALL OTHER WARRANTIES AND REPRESENTATIONS, EXPRESSED OR IMPLIED, AND ALL OTHER OBLIGATIONS OR LIABILITIES ON THE PART OF RKI INSTRUMENTS, INC. INCLUDING BUT NOT LIMITED TO, THE WARRANTY OF MERCHANTABILITY OR FITNESS FOR A PARTICULAR PURPOSE. IN NO EVENT SHALL RKI INSTRUMENTS, INC. BE LIABLE FOR INDIRECT, INCIDENTAL, OR CONSEQUENTIAL LOSS OR DAMAGE OF ANY KIND CONNECTED WITH THE USE OF ITS PRODUCTS OR FAILURE OF ITS PRODUCTS TO FUNCTION OR OPERATE PROPERLY.*

This warranty covers instruments and parts sold to users by authorized distributors, dealers, and representatives as appointed by RKI Instruments, Inc.

We do not assume indemnification for any accident or damage caused by the operation of this gas monitor, and our warranty is limited to the replacement of parts or our complete goods.

---

## Table of Contents

<b>Overview</b> .....	<b>5</b>
<b>Specifications</b> .....	<b>5</b>
<b>Description</b> .....	<b>6</b>
Oxygen Detector .....	7
Calibration Adapter/Splash Guard .....	8
Amplifier .....	8
Amplifier Junction Box .....	9
Detector Junction Box .....	9
<b>Installation</b> .....	<b>10</b>
Mounting the Oxygen Transmitter .....	10
Wiring the Detector to the Amplifier .....	12
Wiring the Amplifier to a Controller .....	14
<b>Startup</b> .....	<b>15</b>
Introducing Incoming Power .....	15
Setting the Fresh Air Signal .....	16
<b>Maintenance</b> .....	<b>17</b>
Preventive Maintenance .....	17
Troubleshooting .....	18
Replacing Components of the Oxygen Transmitter .....	19
<b>Calibration Frequency</b> .....	<b>21</b>
<b>Determining Response Time</b> .....	<b>21</b>
<b>Calibration</b> .....	<b>22</b>
Preparing for Calibration .....	22
Setting the Fresh Air Reading .....	23
Setting the Zero Reading .....	23
Returning to Normal Operation .....	23
<b>Parts List</b> .....	<b>24</b>

---

## Overview

This manual describes the 65-2322-04SS explosion-proof oxygen (O<sub>2</sub>) transmitter. This manual also describes how to install, start up, maintain, and calibrate the transmitter. A parts list at the end of this manual lists replacement parts and accessories for the oxygen transmitter.

---

## Specifications

---

***WARNING: Do not use this product in a manner not specified in this instruction manual.***

---

Table 1 lists specifications for the oxygen transmitter.

**Table 1: Specifications**

<b>Target Gas</b>	Oxygen (O <sub>2</sub> )
<b>Detection Range</b>	0 to 100 PPM (parts per million)
<b>Area Classification</b>	Explosion-proof for Class I, Groups B, C, and D
<b>Temperature Code</b>	T6
<b>Installation Category</b>	Installation Category 1. Signal level, special equipment or parts of equipment, telecommunication, electronic, etc., with smaller transient overvoltages than Installation Category (Overvoltage Category) II (ref. IEC 664).
<b>Input Voltage</b>	11 VDC - 30 VDC
<b>Sampling Method</b>	Diffusion
<b>Signal Output</b>	4 to 20 mA
<b>Oxygen Detector Signal Output</b>	0 mV at 0% oxygen nominal 18 mV at 25% oxygen nominal
<b>Response Time</b>	90% in 30 seconds
<b>Accuracy</b>	± 0.5% O <sub>2</sub>

---

**NOTE:** The following symbol on the detector label is a caution to the user to refer to this documentation for installation and operation instructions: 

---

---

***WARNING: When using the 65-2322-04SS, you must follow the instructions and warnings in this manual to assure proper and safe operation of the 65-2322-04SS and to minimize the risk of personal injury. Be sure to maintain and periodically calibrate the 65-2322-04SS as described in this manual.***

---

## Description

This section describes the components of the oxygen transmitter. The transmitter is a 4 - 20 mA type detector head. It consists of the oxygen detector, calibration adapter/splash guard, amplifier, the amplifier junction box, and the detector junction box. The two-junction-box configuration is intended for situations where the detector needs to be installed at an inaccessible location. The detector junction box can be installed at the inaccessible location and the amplifier junction box can be installed in a more readily accessible area.

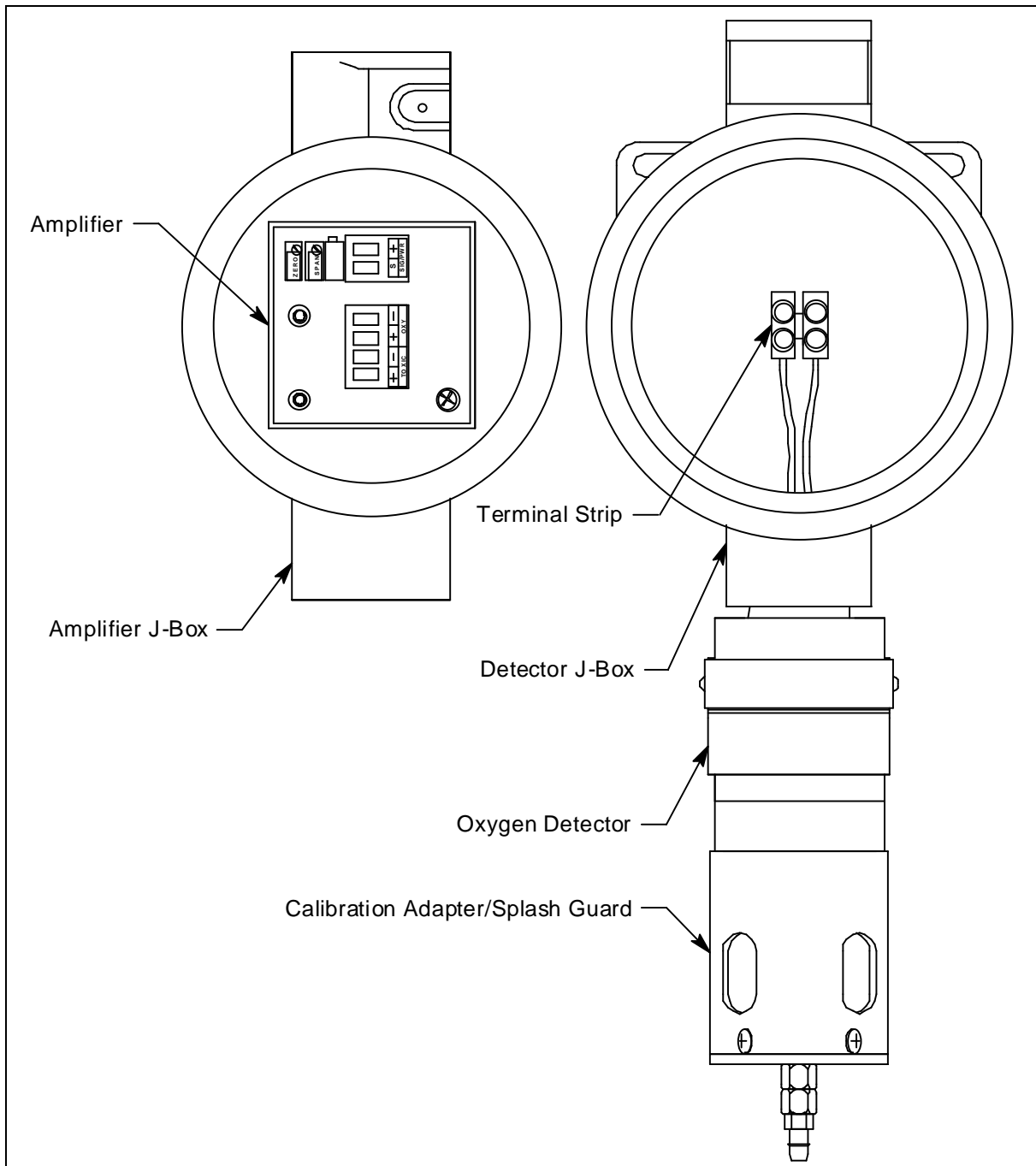

**Figure 1: Component Location**

## Oxygen Detector

The oxygen detector consists of the detector housing body, detector housing cap, cap gasket, and the plug-in sensor.

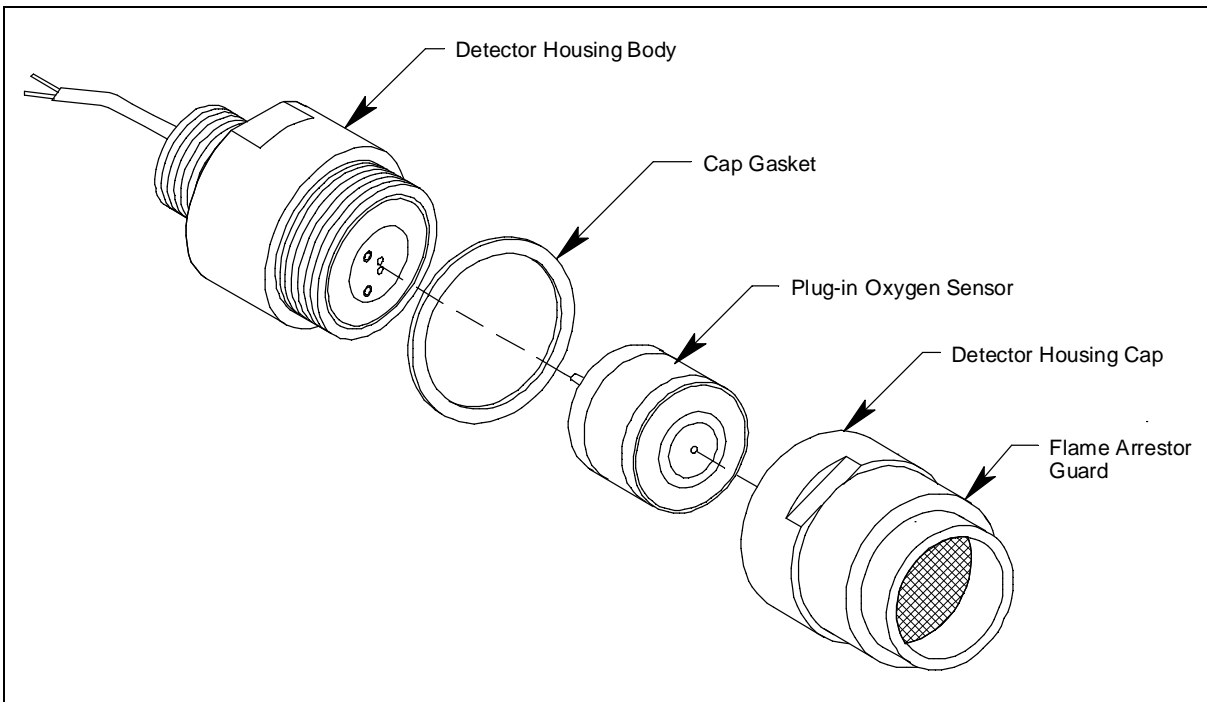

**Figure 2: Oxygen Detector Component Location**

### ***Detector Housing Body***

The detector housing body protects the electronic components within the housing. Use the mounting threads at the top of the housing to screw the oxygen detector into the 3/4 NPT hub on the bottom of the junction box. Two wires extend from the top of the detector housing body. Use these wires to connect the oxygen detector to the amplifier. One of the wires is white and one of the wires is green.

The housing includes two sockets installed on a circuit board. These sockets accept the plug-in sensor's two pins to provide electrical connection for the sensor. The circuit board with the sockets conditions the sensor's signal before the signal reaches the amplifier.

### ***Housing Cap & Cap Gasket***

The housing cap screws onto the detector housing. It retains the plug-in sensor and protects it from damage. A foam gasket is installed inside the housing cap that seals against the sensor face. The housing cap also includes a flame arrester which contains any sparks that may occur within the detector and a flame arrester guard which protects the flame arrester from damage. Unscrew the detector cap to access the plug-in sensor for maintenance or replacement. A cap gasket seals the interface between the housing and cap.

### ***Plug-In Oxygen Sensor***

The plug-in sensor is secured in the detector assembly by the housing cap. Through a series of chemical and electrical reactions, the sensor produces a millivolt output that corresponds to the detection range of the transmitter.

## Calibration Adapter/Splash Guard

A calibration adapter/splash guard is installed on the oxygen detector. A fitting at the bottom of the calibration adapter/splash guard allows a length of tubing to be connected for calibration and routed to a more easily accessible location (near the amplifier junction box is optimal for ease of calibration). The calibration adapter/splash guard also protects the detector from splashing water or direct water spray.

## Amplifier

The amplifier converts the electrical output from the sensor to a 4 to 20 mA signal that corresponds to the detection range and transmits the signal to a gas monitoring controller. A foam gasket that orients the amplifier and keeps it from rotating is installed on the bottom of the amplifier. The amplifier includes the controller terminal strip, detector terminal strip, zero pot, span pot, and test points (Figure 3).

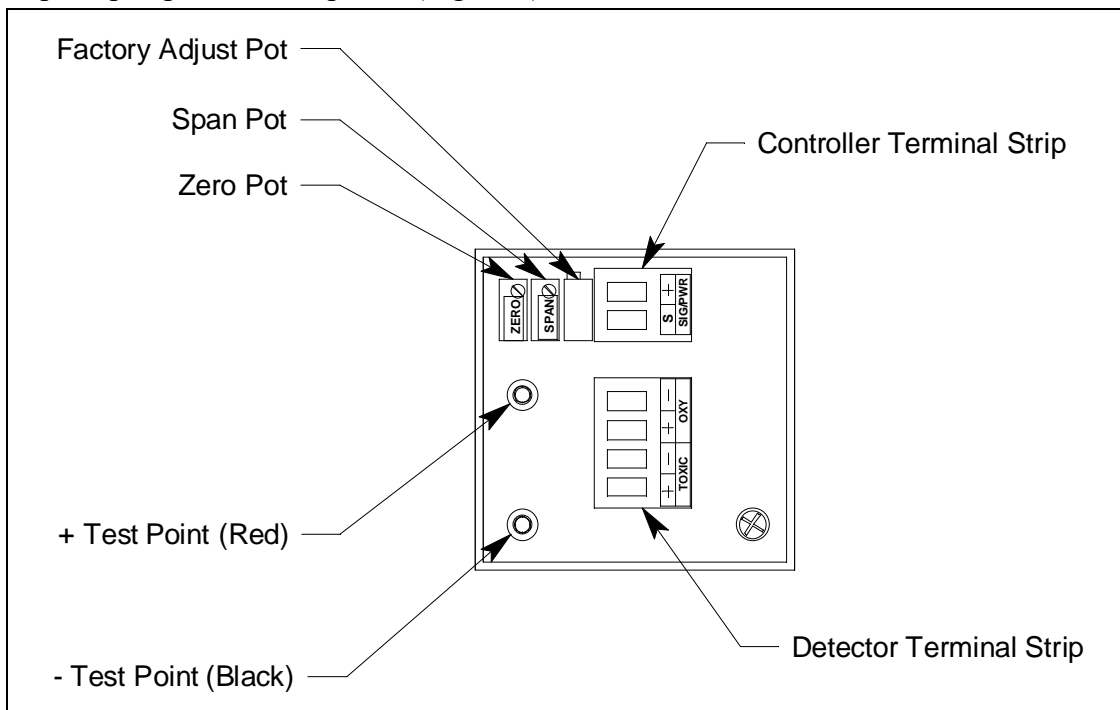

**Figure 3: Amplifier Component Location**

### ***Controller Terminal Strip***

The controller terminal strip is a two position plug-in style terminal strip located at the top edge of the amplifier. Use the controller terminal strip to connect the amplifier to a controller.

### ***Detector Terminal Strip***

The detector terminal strip is a four-point plug-in style terminal strip near the bottom of the amplifier. Use the detector terminal strip to connect the oxygen detector to the amplifier.

### ***Zero Pot***

The zero pot is located in the upper left corner of the amplifier (see Figure 3). Use a small flat blade screwdriver to turn the zero pot's adjustment screw and adjust the amplifier's zero (oxygen free) output during the calibration procedure. Turn the adjustment screw clockwise to



increase the zero output and counterclockwise to decrease the zero output.

### **Span Pot**

The span pot is located to the right of the zero pot (see Figure 3). Use a small flat blade screwdriver to turn the span pot's adjustment screw and adjust the amplifier's fresh air output during the start up and calibration procedures. Turn the adjustment screw clockwise to increase the output and counterclockwise to decrease the output.

---

**CAUTION:** *The third potentiometer is factory-set. Do not adjust it.*

---

### **Test Points**

The test points (red and black) are on the left side of the amplifier (see Figure 3). The test points produce a 100mV to 500 mV output that corresponds to the transmitter's 4 to 20 mA output. Use the test points and a voltmeter to measure the transmitter's output during the start-up and calibration procedures. The black test point in the lower left corner is the negative (-) test point and the red test point below the zero pot is the positive (+) test point.

### **Amplifier Junction Box**

The amplifier junction box protects the amplifier and wiring connections made to the amplifier. Use the top 3/4 NPT conduit hub to connect wiring from the amplifier to the controller. Use the bottom 3/4 NPT conduit hub to wire the remotely installed oxygen detector. Use the cover on the front of the junction box to access the interior of the junction box. The amplifier is factory installed in the junction box. Three spacers installed on the back of the junction box control the distance of the junction box from a mounting surface.

### **Detector Junction Box**

The stainless steel detector junction box is intended to be installed remotely from the amplifier junction box. The oxygen detector is factory installed in the bottom 3/4 NPT conduit hub. A terminal strip is provided for wiring connections and the detector is factory wired to one side of this terminal strip. The other side of the terminal strip is for user-supplied wiring to the detector terminal strip located in the amplifier junction box. This wiring should go through the top 3/4 NPT conduit hub. An O-ring seals the interface between the junction box cover and the junction box base.

A cover on the front of the junction box allows access to the interior of the junction box. A locking set screw on the junction box cover allows you to secure the junction box cover and prevent it from being removed.

## Installation

This section describes procedures to mount the oxygen transmitter in the monitoring environment and wire the transmitter to a controller.

### Mounting the Oxygen Transmitter

1. Select a mounting site that is representative of the monitoring environment. Consider the following when you select the mounting site.
  - For the amplifier junction box, select a site where the junction box is not likely to be bumped or disturbed. Make sure there is sufficient room to perform start-up, maintenance, and calibration procedures. The site should be easily accessible.
  - For the detector junction box, select a site that is at breathing level.
  - The junction boxes should be mounted no further than 200 feet from each other.
2. Amplifier junction box dimensions are shown in Figure 4. Detector junction box dimensions are shown in Figure 5.

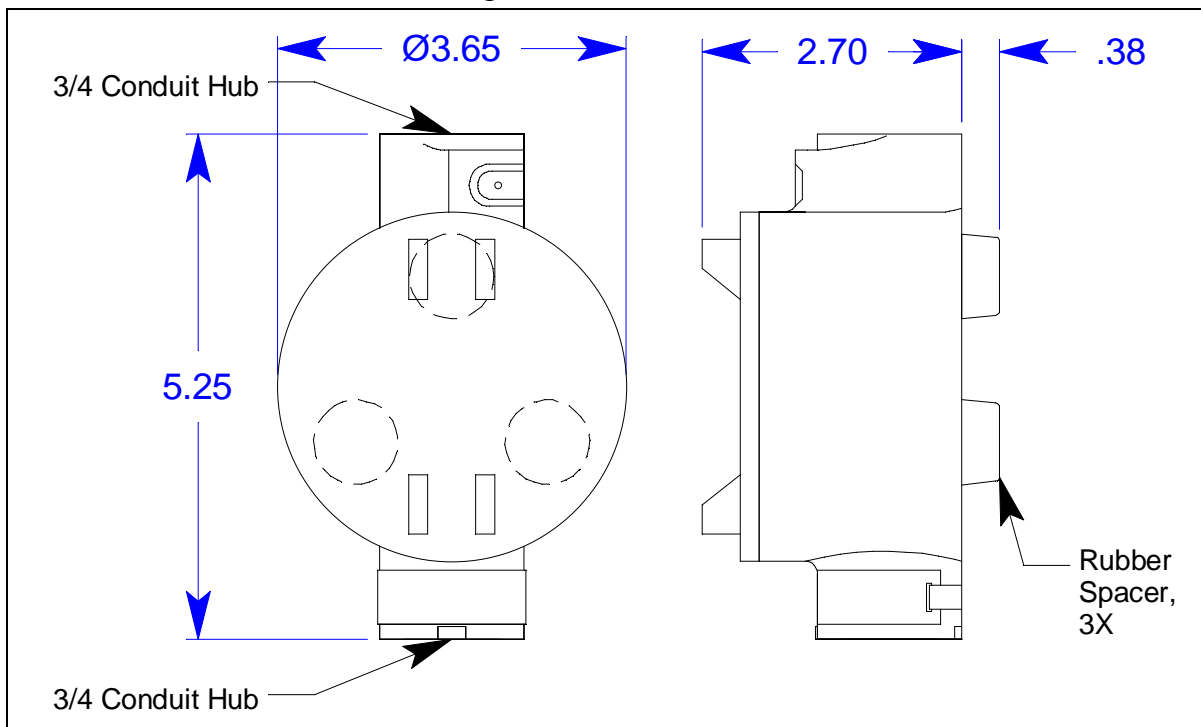

**Figure 4: Amplifier Junction Box Dimensions**

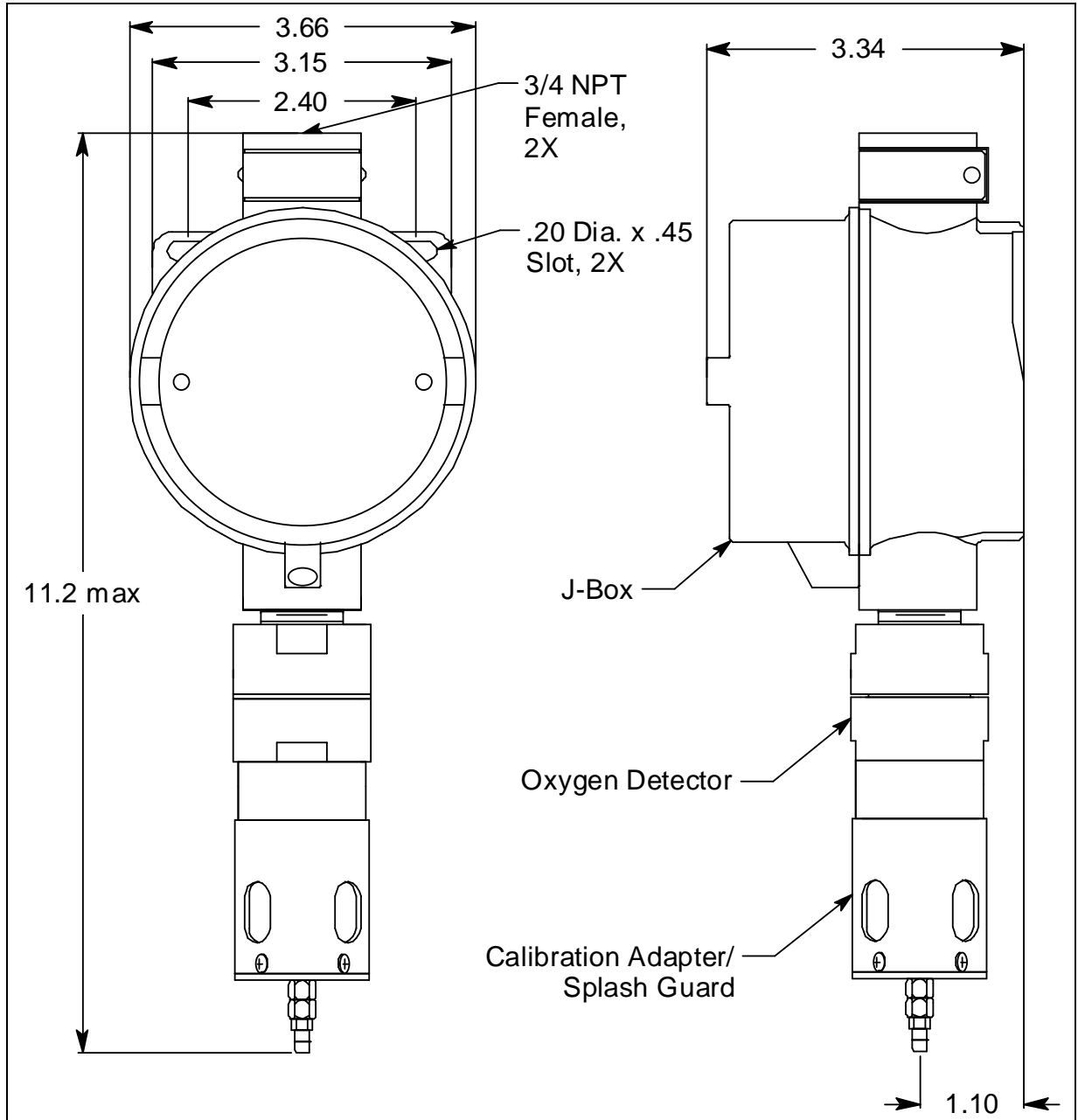

**Figure 5: Detector Junction Box Dimensions**

3. At the monitoring site you select, hang or mount the detector junction box with the detector facing down (see Figure 5).
4. Install 3/16 inch I.D. flexible polyurethane tubing to the fitting at the bottom of the calibration adapter/splash guard and route it to an accessible area that is close to the amplifier junction box. See the “Parts List” on page 24 for available tubing.

## Wiring the Detector to the Amplifier

---

**WARNING:** Always verify that power to the controller is OFF before you make wiring connections.

---

1. Confirm that no power is being applied to the amplifier. If the amplifier has already been connected to a controller, turn off the controller and turn off or unplug power to the controller.
2. Remove the detector junction box's cover from the junction box.
3. Remove the amplifier junction box's cover from the junction box.
4. To maintain the explosion proof classification of the junction boxes, conduit seals must be installed as shown in Figure 6. Adhere to your local electrical code when installing the conduit seal.
5. Guide a two-conductor, shielded cable or two wires in conduit through the top conduit hub of the detector junction box. To make wiring more convenient, use wire colors that correspond to the detector wire colors: white and green.

---

**NOTE:** Consult RKI Instruments, Inc. for cable lengths longer than 200 feet.

---

6. Connect the wires to the terminal block in the detector junction box.

---

**CAUTION:** If shielded cable is used, leave the cable shield's drain wire disconnected and insulated at the detector junction box. You will connect the opposite end of the cable's drain wire to the amplifier junction box's chassis (earth) ground.

---

7. Secure the detector junction box's cover to the junction box.
8. Guide the other end of the two-conductor, shielded cable or two wires in conduit through the bottom conduit hub of the amplifier junction box.
9. To gain access to a plug-in terminal strip for wiring, pull it out of its socket by grasping the terminal strip and pulling. The detector strip is keyed so that the controller and detector terminal strips cannot be reversed inadvertently.

10. Pull out the detector terminal strip and connect the two wires to the terminal strip as follows (see Figure 6).

- Connect the wire corresponding to the detector's white wire to the **OXY "+"** terminal.
- Connect the wire corresponding to the detector's green wire to the **OXY "-"** terminal.

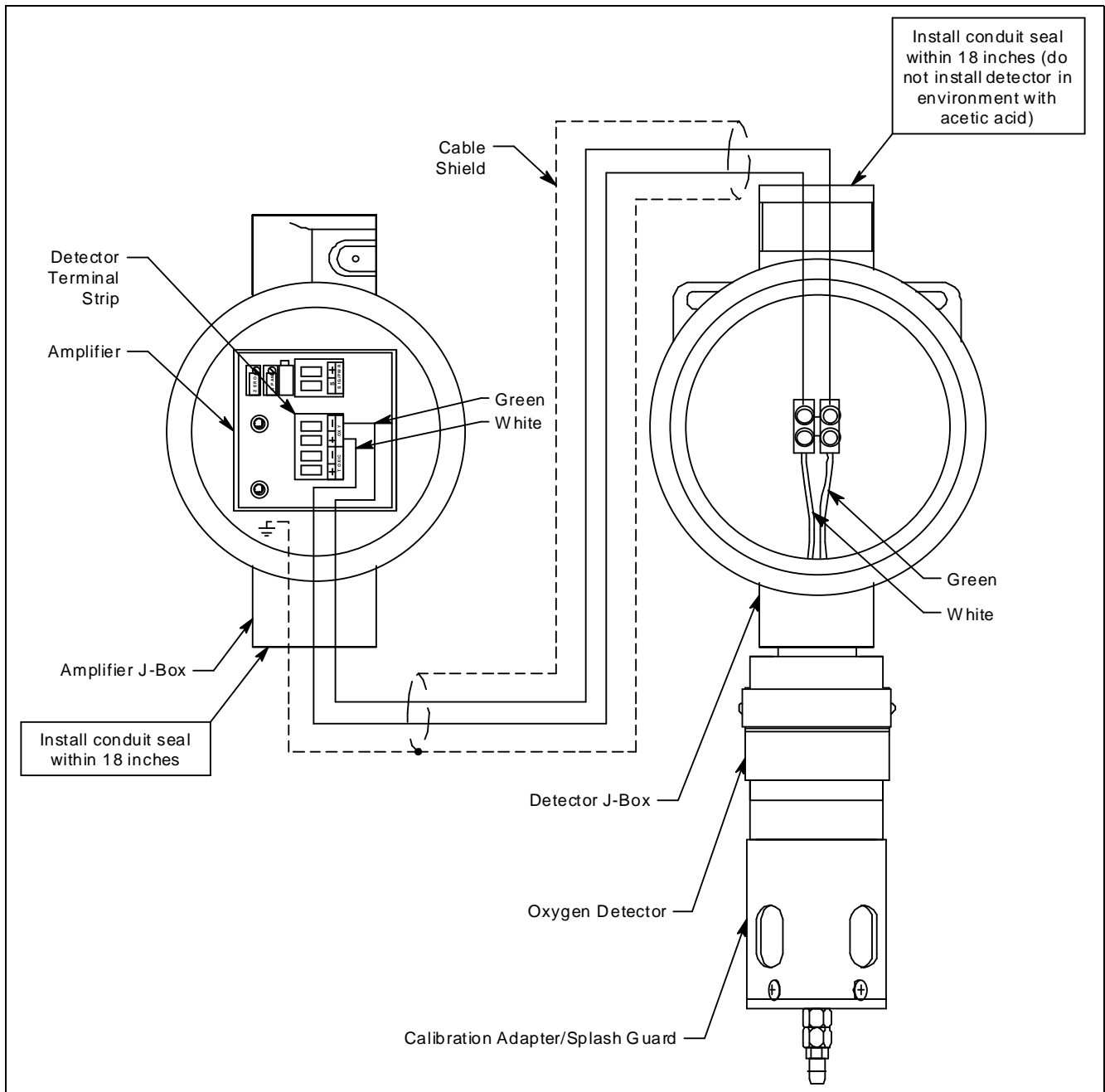

**Figure 6: Wiring Detector to Amplifier**

11. Reinstall the detector terminal strip into its socket.
12. Secure the amplifier junction box's cover to the junction box.
13. If shielded cable is used, connect the cable's drain wire to an available chassis (earth) ground at the amplifier junction box. The amplifier mounting screw is a convenient

grounding location. Install a lug on the shield drain wire or wrap the shield drain wire around the mounting screw. Do not connect the shield drain wire at the detector junction box.

## Wiring the Amplifier to a Controller

---

***WARNING: If the controller's construction is not explosion-proof, the controller must be installed in an ordinary location. Do not install a non-explosion-proof controller in a classified location.***

---

1. Turn off the controller.
2. Turn off or unplug power to the controller.
3. Remove the amplifier junction box's cover from the junction box.
4. Guide a two-conductor, shielded cable, or two wires in conduit through the top conduit hub of the amplifier junction box.
5. To maintain the explosion proof classification of the amplifier junction box, a conduit seal must be used as shown in Figure 7 in addition to those shown in Figure 6. Adhere to your local electrical code when installing the conduit seal.
6. Pull out the controller terminal strip and connect the two wires to the terminal strip as follows (see Figure 7).
  - Connect the positive wire to the terminal labeled **SIG/PWR “+”** terminal.
  - Connect the signal wire to the terminal labeled **SIG/PWR “S”** terminal.

---

***CAUTION: If shielded cable is used, leave the cable shield's drain wire disconnected and insulated at the amplifier junction box. You will connect the opposite end of the cable's drain wire to the controller's chassis (earth) ground.***

---

7. Reinstall the controller terminal strip into its socket.
8. Secure the amplifier junction box's cover to the junction box.
9. Route the cable or wires leading from the amplifier junction box through one of the conduit hubs at the controller housing.

---

***CAUTION: Do not route power and transmitter wiring through the same controller conduit hub. The power cable may disrupt the transmission of the transmitter signal to the controller.***

---

10. Connect the wires to the applicable detector/transmitter terminal strip at the controller as shown in Figure 7.

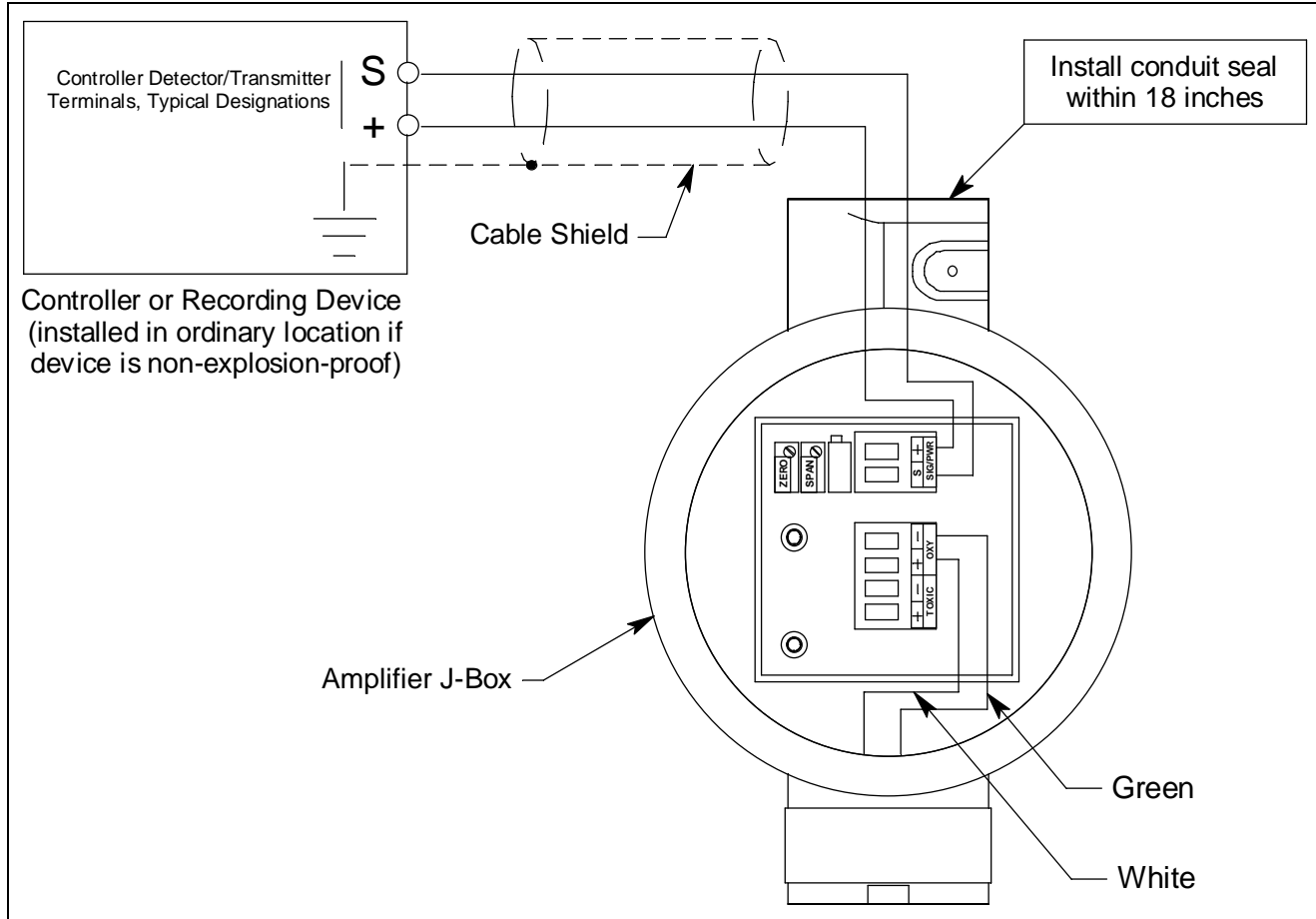

**Figure 7: Wiring the Amplifier to a Controller**

11. If shielded cable is used, connect the cable's drain wire to an available chassis (earth) ground at the controller. RKI controllers typically have a ground stud that can be used to ground the cable's drain wire.

## Start Up

This section describes procedures to start up the oxygen transmitter and place the transmitter into normal operation.

### Introducing Incoming Power

1. Complete the installation procedures described earlier in this manual.
2. Verify that the power wiring to the controller is correct and secure. Refer to the controller operator's manual.
3. Turn on power to the controller.
4. Turn on the controller.
5. Verify that the controller is on and operating properly. Refer to the controller operator's manual.

---

**NOTE:** When first powered up, the transmitter will enter about a one minute period when the 4-20 mA output is stabilizing and may be well above or below the fresh air reading momentarily. RKI controllers have a one minute warmup period when the controller does not display any gas reading or give any alarm indication. The oxygen transmitter's 4-20 mA signal should be stable by the time the controller's warmup period is over.

---

**CAUTION:** *Allow the transmitter to warm up for 5 minutes before you continue with the next section, "Setting the Fresh Air Signal".*

---

### **Setting the Fresh Air Signal**

---

**WARNING:** *Do not remove the detector housing cap or either of the junction box covers while the circuits are energized unless the area is determined to be non-hazardous. Keep the detector housing cap and junction box covers tightly closed during operation.*

---

**NOTE:** If you can verify that the detector is in a fresh air environment (environment known to be of normal oxygen content and free of toxic and combustible gases), it is not necessary to apply zero air when verifying or setting the fresh air reading.

---

The procedure below describes applying zero emission air, usually called zero air, using a calibration kit that includes calibration gas and a fixed flow regulator with an on/off knob. RKI Instruments, Inc. recommends using a 0.5 LPM (liters per minute) fixed flow regulator.

1. Unscrew and remove the amplifier junction box's cover from the junction box.
2. Set a voltmeter to measure in the millivolt (mV) range.
3. Plug the voltmeter leads into the test points on the amplifier. Plug the positive lead into the red (+) test point; plug the negative lead into the black (-) test point.
4. Screw the regulator into the zero air calibration cylinder.
5. Use the flexible tubing coming from the calibration adapter/splash guard to connect the regulator to the calibration cup.
6. Turn the regulator's on/off knob counterclockwise to open it. Gas will begin to flow.
7. Allow the gas to flow for the length of time determined in "Determining Response Time" on page 21.
8. Verify a voltmeter reading of 434 mV ( $\pm 2$  mV).
9. If necessary, use a small flat-blade screwdriver to adjust the span pot until the voltmeter reading is 434 mV ( $\pm 2$  mV).
10. Turn the regulator's on/off knob clockwise to close it.



11. Disconnect the calibration adapter/splash guard's flexible tubing from the regulator.

---

**NOTE:** Do not disconnect the flexible tubing from the calibration adapter/splash guard.

---

12. Unscrew the regulator from the zero air calibration cylinder.

13. Store the components of the calibration kit in a safe and convenient place.

14. Remove the voltmeter leads from the test points.

15. Secure the amplifier junction box cover to the junction box.

---

## **Maintenance**

This section describes maintenance procedures. It includes preventive maintenance, troubleshooting, and component replacement procedures.

### **Preventive Maintenance**

This section describes a preventive maintenance schedule to ensure the optimum performance of the oxygen transmitter. It includes daily and quarterly procedures.

#### ***Daily***

Verify a display reading of 20.9% volume oxygen at the controller. Investigate significant changes in the display reading.

#### ***Quarterly***

Calibrate the oxygen transmitter as described in "Calibration" on page 22. See the calibration frequency discussion in "Calibration Frequency" on page 21 to determine if a quarterly calibration schedule fits your needs.

## Troubleshooting

The troubleshooting guide describes symptoms, probable causes, and recommended action for problems you may encounter with the oxygen transmitter.

---

**NOTE:** This troubleshooting guide describes transmitter problems only. See the controller operator’s manual for problems you may encounter with the controller.

---

**Table 2: Troubleshooting the Oxygen Transmitter**

Condition	Symptom(s)	Probable Causes	Recommended Action
Fail Condition	<ul style="list-style-type: none"> <li>Controller indicates a fail condition.</li> </ul>	<ul style="list-style-type: none"> <li>The detector-to-amplifier or amplifier-to-controller wiring is disconnected or misconnected.</li> <li>The plug-in sensor is not properly plugged into the sockets in the detector housing body.</li> <li>The transmitter’s fresh air reading is low enough to cause a fail condition.</li> <li>The transmitter is malfunctioning.</li> </ul>	<ol style="list-style-type: none"> <li>Verify that the detector-to-amplifier and amplifier-to-controller wiring is correct and secure.</li> <li>Confirm that the plug-in sensor is installed properly.</li> <li>Perform a fresh air adjustment. A full calibration is recommended.</li> <li>If the fail condition continues, replace the plug-in sensor as described later in this section.</li> <li>If the fail condition continues, contact RKI for further instruction.</li> </ol>
Slow or No Response/ Difficult or Unable to Calibrate	<ul style="list-style-type: none"> <li>Unable to accurately set the fresh air or zero reading during calibration.</li> <li>Transmitter requires frequent calibration.</li> </ul> <p><i>Note: Under “normal” circumstances, the transmitter requires calibration once every 3 months. Some applications may require a more frequent calibration schedule.</i></p>	<ul style="list-style-type: none"> <li>The calibration cylinder is low, outdated, or defective.</li> <li>The flame arrestor in the detector housing cap is wet or clogged with dirt or other particulates.</li> <li>The calibration gas is not an appropriate concentration.</li> <li>The transmitter is malfunctioning.</li> <li>The flexible tubing to the calibration adapter/splash guard has become kinked, blocked, or disconnected.</li> </ul>	<ol style="list-style-type: none"> <li>Verify that the calibration cylinder contains an adequate supply of a fresh test sample.</li> <li>Check the detector housing cap to determine if the flame arrestor is wet or dirty. Clean if necessary.</li> <li>Verify that the calibration gas concentration is appropriate for the transmitter. Zero emission air (20.9% oxygen) is normally used for a fresh air adjustment if the environment is suspect and 100% nitrogen (0% oxygen) is normally used for a zero adjustment.</li> <li>Verify that the flexible tubing to the calibration adapter/splash guard is clear and connected to the calibration adapter/splash guard.</li> <li>If the calibration/response difficulties continue, replace the plug-in sensor as described later in this section.</li> <li>If the calibration/response difficulties continue, contact RKI for further instruction.</li> </ol>

## Replacing Components of the Oxygen Transmitter

This section includes a procedure to replace the oxygen plug-in sensor, the oxygen detector assembly, and the amplifier. In most cases, it is not necessary to replace the entire detector assembly.

### Replacing the Plug-In Oxygen Sensor

---

**CAUTION:** *The sensor contains electrolyte which is a dilute acid. Do not disassemble the sensor when replacing it with a new one. If sensor electrolyte comes in contact with your skin, wash affected area thoroughly with soap and water.*

---

1. Turn off the controller.
2. Turn off or unplug power to the controller.
3. Unscrew the detector housing cap from the detector housing body. Make sure not to lose the cap gasket.
4. Unplug and remove the oxygen sensor.
5. Carefully plug the replacement sensor into the socket pattern that is located in the detector housing.
6. Make sure the cap gasket is in place and screw the detector housing cap back onto the detector housing body.
7. Turn on or plug in power to the controller.
8. Turn on the controller and place into normal operation.

---

**CAUTION:** *Allow the replacement sensor to warm up for 5 minutes before you continue with the next step.*

---

9. Calibrate the transmitter as described in the “Calibration” on page 22.

### Replacing the Oxygen Detector

---

**NOTE:** In most cases, it is only necessary to replace the plug-in oxygen sensor.

---

1. Turn off the controller.
2. Turn off or unplug power to the controller.
3. Unscrew the calibration adapter/splash guard from the detector.
4. Remove the detector junction box’s cover from the junction box.
5. Remove the detector terminal strip from its socket.
6. Disconnect the detector leads from the detector terminal strip. Note the position of the color-coded leads as you remove them.
7. Unscrew the detector from the detector junction box conduit hub.

8. Guide the detector leads of the replacement detector through the bottom conduit hub of the detector junction box, then screw the mounting threads of the detector into the conduit hub. If necessary for environmental conditions, apply thread sealant or Teflon tape to the hub and/or detector threads to seal them.
9. Connect the detector leads to the appropriate detector terminal strip terminals. Connect the wire corresponding to the detector's white wire to the terminal labeled **OXY "+"** and the wire corresponding to the detector's green wire to the terminal labeled **OXY "-"**. See Figure 6 for the detector wiring connections to the amplifier.
10. Screw the calibration adapter/splash guard onto the new detector.
11. Reinstall the detector terminal strip into its socket.
12. Reinstall the detector junction box cover.
13. Turn on or plug in power to the controller.
14. Turn on the controller and place it into normal operation.

---

**CAUTION:** *Allow the replacement detector to warm up for 5 minutes before you continue with the next step.*

---

15. Calibrate the replacement detector as described in "Calibration" on page 22.

### **Replacing the Amplifier**

---

**NOTE:** The amplifier is not housed in the same junction box as the oxygen detector. The amplifier junction box should be somewhere accessible.

---

1. Turn off the controller.
2. Turn off or unplug power to the controller.
3. Remove the amplifier junction box's cover.
4. Unplug the detector terminal strip and controller terminal strip from their sockets. You may leave the wires connected to the terminal strips.
5. Unscrew and remove the screw with the flat and lock washers that secures the amplifier to the junction box. The screw is at the bottom right of the amplifier.
6. Remove the old amplifier.
7. Place the new amplifier in the same position as the old amplifier. A foam gasket that orients the amplifier and keeps it from rotating is installed on the bottom of the amplifier. Make sure the amplifier is seated flat in the junction box.
8. Install the new amplifier into the junction box with the screw, lock washer, and flat washer you removed in Step 5.
9. Install the detector and controller terminals strips into their sockets on the new amplifier as shown in Figure 6 and Figure 7. If controller leads or detector leads were removed during this procedure, refer to Figure 6 and Figure 7 for the detector and amplifier

connections.

---

**NOTE:** When a transmitter is first powered up with a new amplifier, the initial output may be either high or low depending on the setting of the span pot. Be sure to make arrangements so that this does not cause unwanted alarms.

---

10. Reinstall the amplifier junction box cover.
11. Turn on or plug in power to the controller.
12. Turn on the controller and place it into normal operation.
13. Allow the transmitter to warm up for 5 minutes.
14. Calibrate the oxygen transmitter as described in the “Calibration” on page 22.

---

## Calibration Frequency

Although there is no particular calibration frequency that is correct for all applications, a calibration frequency of every 3 months is adequate for most oxygen transmitter applications. Unless experience in a particular application dictates otherwise, RKI Instruments, Inc. recommends a calibration frequency of every 3 months for the oxygen transmitter.

If an application is not very demanding, for example detection in a clean, temperature controlled environment, and calibration adjustments are minimal at calibration, then a calibration frequency of every 6 months is adequate.

If the application is very demanding, for example if the environment is not well controlled, then more frequent calibration than every 3 months may be necessary.

---

## Determining Response Time

Since the detector junction box is installed remotely from the amplifier, the response time of the detector will depend on the length of flexible tubing that is attached to the calibration adapter/splash guard. To determine the response time based on the length of tubing connected:

1. Place the controller into its calibration mode or disable external alarms.
2. Note the current gas reading displayed at the controller.
3. Screw the regulator into the calibration cylinder. Do not use a zero air cylinder for this operation.
4. Use the flexible tubing coming from the calibration adapter/splash guard to connect the regulator to the calibration cup.
5. Turn the regulator’s on/off knob counterclockwise to open the regulator. Gas will begin to flow. Take note of the time or start a stopwatch.
6. When you first start to notice an increase in the gas reading, note how much time passed between starting the gas flow and noticing a reading response.
7. Turn the regulator’s on/off knob clockwise to close the regulator.

8. Unscrew the regulator from the calibration cylinder.
9. Disconnect the calibration adapter/splash guard's flexible tubing from the regulator.

---

**NOTE:** Do not disconnect the flexible tubing from the calibration adapter/splash guard.

---

10. Add 1 minute to the length of time determined in Step 6. This is the response time for the detector. When performing a fresh air adjustment or zero adjustment, gas must be applied for this length of time.

---

## Calibration

This section describes how to calibrate the oxygen transmitter. It includes procedures to prepare for calibration, set the fresh air reading, set the zero reading, and return to normal operation. It describes the test using a calibration kit that includes calibration gas and a fixed flow regulator with an on/off knob. RKI Instruments, Inc. recommends using a 0.5 LPM (liters per minute) fixed flow regulator.

### Preparing for Calibration

---

**NOTE:** Calibrating the oxygen transmitter may cause alarms. Be sure to put the controller into its calibration program or disable external alarms before calibration.

---

---

***WARNING: Do not remove the detector housing cap or either of the junction box covers while the circuits are energized unless the area is determined to be non-hazardous. Keep the detector housing cap and junction box covers tightly closed during operation.***

---

1. Unscrew and remove the amplifier junction box's cover.
2. Set a voltmeter to measure in the millivolt (mV) range.
3. Plug the voltmeter leads into the test points on the amplifier. Plug the positive lead into the red (+) test point; plug the negative lead into the black (-) test point.
4. Use the following formula to determine the correct test points output for the calibrating sample.

$$\text{Output (mV)} = (\text{calibrating sample/fullscale}) \times 400 + 100$$

The concentration of oxygen in the atmosphere is 20.9%, so when setting the fresh air reading, you will set the test points output to 434 mV ( $\pm 2$  mV).

$$434(\text{mV}) = (20.9/25) \times 400 + 100$$

5. Place the controller into its calibration mode or disable external alarms.

---

**NOTE:** Calibrating the oxygen transmitter may cause alarms. Be sure to put the controller into its calibration mode or disable external alarms before continuing.

---

### **Setting the Fresh Air Reading**

---

**NOTE:** If you can verify that the oxygen transmitter is in a fresh air environment, you do not need to apply zero air to the detector before adjusting the fresh air reading.

---

1. Screw the regulator into the zero air calibration cylinder.
2. Use the flexible tubing coming from the calibration adapter/splash guard to connect the regulator to the calibration cup.
3. Turn the regulator knob counterclockwise to open the regulator.
4. Allow the gas to flow for the length of time determined in “Determining Response Time” on page 21.
5. Verify a reading of 434 mV ( $\pm 2$ mV). If necessary, use the span pot on the amplifier to adjust the reading to 434 mV ( $\pm 2$ mV).
6. Unscrew the regulator from the zero air calibration cylinder.
7. Leave the calibration adapter/splash guard’s flexible tubing connected to the regulator.

### **Setting the Zero Reading**

1. Screw the regulator into the calibration cylinder. Verify that the calibration gas is representative of the transmitter’s target gas.
2. Turn the regulator knob counterclockwise to open the regulator.
3. Allow the calibration gas to flow for the length of time determined in “Determining Response Time” on page 21.
4. Verify a reading of 100 mV ( $\pm 2$ mV). If necessary, use the zero pot on the amplifier to adjust the reading to match the correct response reading.
5. Turn the regulator knob clockwise to close the regulator.
6. Unscrew the regulator from the calibration cylinder.

### **Returning to Normal Operation**

1. Remove the voltmeter leads from the amplifier test points.
2. Disconnect the calibration adapter/splash guard’s flexible tubing from the regulator.

---

**NOTE:** Do not disconnect the flexible tubing from the calibration adapter/splash guard.

---

3. Secure the amplifier junction box’s cover to the junction box.
4. When the display reading rises above the decreasing alarm’s setpoint, return the controller to normal operation.

5. Verify that the controller display reading decreases and stabilizes at 20.9% volume.
6. Store the components of the calibration kit in a safe and convenient place.

---

## Parts List

Table 5 lists replacement parts and accessories for the oxygen transmitter.

**Table 3: Parts List**

<b>Part Number</b>	<b>Description</b>
06-1248RK	Sample tubing (order by the foot)
07-0033RK	Detector housing cap gasket
07-7151RK	O-ring for detector junction box
10-5153RK	Lid-locking set screw for detector junction box
18-0416RK-11	Junction box with cover, stainless steel (for detector junction box)
18-0400RK-01	Junction box with rubber spacers (for amplifier junction box)
57-1064RK-01	S2 series oxygen amplifier with orienting gasket
65-2322-04SS	Oxygen transmitter (includes detector, two junction boxes, and amplifier), CSA classified
65-1025RK	Oxygen plug-in sensor
65-2514RK	Oxygen replacement detector assembly (includes plug-in sensor), CSA classified
71-0481	65-2322-04SS Oxygen Transmitter Operator's Manual (this document)
81-0076RK-01	Zero air calibration cylinder, 34 liter steel
81-0078RK-01	100% nitrogen calibration cylinder, 34 liter steel
81-0078RK-03	100% nitrogen calibration cylinder, 103 liter
81-1050RK	Regulator with gauge and knob, 0.5 LPM, for 17 liter and 34 liter steel calibration cylinders (cylinders with external threads)
81-1051RK	Regulator with gauge and knob, 0.5 LPM, for 34 liter aluminum, 58 liter, and 103 liter calibration cylinders (cylinders with internal threads)
81-1116RK	Calibration adapter/splash guard