



INSTRUMENTS

**30-0954-209-01 Series Sample Draw
Aspirator Adapter
Operator's Manual**

Part Number: 71-0403

Revision: B

Released: 5/29/20

WARNING

Read and understand this instruction manual before operating detector. Improper use of the detector could result in bodily harm or death.

Periodic calibration and maintenance of the detector is essential for proper operation and correct readings. Please calibrate and maintain this detector regularly! Frequency of calibration depends upon the type of use you have and the sensor types.

Typical calibration frequencies for most applications are between 3 and 6 months, but can be required more often or less often based on your usage.

Product Warranty

RKI Instruments, Inc. warrants gas alarm equipment sold by us to be free from defects in materials, workmanship, and performance for a period of one year from the date of shipment from RKI Instruments, Inc. Any parts found defective within that period will be repaired or replaced, at our option, free of charge. Parts must be returned to RKI Instruments, Inc. for repair or replacement. This warranty does not apply to those items which by their nature are subject to deterioration or consumption in normal service, and which must be cleaned, repaired or replaced on a routine basis. Examples of such items are:

- a) Pump diaphragms and valves
- b) Fuses
- c) Batteries
- d) Filter elements

Warranty is voided by abuse including mechanical damage, alteration, rough handling, or repair procedures not in accordance with instruction manual. This warranty indicates the full extent of our liability, and we are not responsible for removal or replacement costs, local repair costs, transportation costs, or contingent expenses incurred without our prior approval.

THIS WARRANTY IS EXPRESSLY IN LIEU OF ANY AND ALL OTHER WARRANTIES AND REPRESENTATIONS, EXPRESSED OR IMPLIED, AND ALL OTHER OBLIGATIONS OR LIABILITIES ON THE PART OF RKI INSTRUMENTS, INC. INCLUDING BUT NOT LIMITED TO, THE WARRANTY OF MERCHANTABILITY OR FITNESS FOR A PARTICULAR PURPOSE. IN NO EVENT SHALL RKI INSTRUMENTS, INC. BE LIABLE FOR INDIRECT, INCIDENTAL OR CONSEQUENTIAL LOSS OR DAMAGE OF ANY KIND CONNECTED WITH THE USE OF ITS PRODUCTS OR FAILURE OF ITS PRODUCTS TO FUNCTION OR OPERATE PROPERLY.

This warranty covers instruments and parts sold to users only by authorized distributors, dealers and representatives as appointed by RKI Instruments, Inc.

We do not assume indemnification for any accident or damage caused by the operation of this gas monitor and our warranty is limited to the replacement of parts or our complete goods. Warranty covers parts and labor performed at RKI Instruments, Inc. only, and does not cover field labor or shipment of parts back to RKI.

Table of Contents

Overview	5
Specifications	5
Description	5
Detector Head(s)	7
Regulator	7
Aspirator	7
Detector Adapter	7
Detector Chamber	7
Dryer	7
Flowmeter	7
Oil Mist Filter	7
Calibration Valve	8
Inlet/Blowback Valve	8
Low Flow/Drain Fault Contact Housing	8
Installation	9
Mounting	9
Wiring	10
Tubing Connections	11
Start Up	12
Normal Operation	12
Calibration	12
Maintenance	13
Blowback Operation	13
Setting the Drain Fault Switch	13
Detector Replacement	14
Replacing the Water Trap's Filter Element	15
Oil Mist Filter Replacement	16
Parts List	18

Overview

This manual describes the 30-0954-209-01 sample draw aspirator adapter. It also describes how to install and use the adapter. A spare parts list at the end of this manual lists replacement parts.

Specifications

Table 1 lists specifications for the Sample Draw Aspirator Adapter.

Table 1: Specifications

Applicable Detector Heads	RKI S Series, S2 Series, M2A, or direct connect detector head
Maximum Compressed Air Supply Pressure	140 psi
Outlet Pressure to Aspirator	5 - 50 psi adjustable (determined by required flow rate)
Recommended Sample Flow Rate	3 SCFH (standard cubic feet per hour)
Low Flow Setpoint	1.6 SCFH (standard cubic feet per hour)

WARNING: *When using the 30-0954-209-01, you must follow the instructions and warnings in this manual to assure proper and safe operation of the 30-0954-209-01 and to minimize the risk of personal injury. Be sure to maintain and calibrate the 30-0954-209-01 as described in this manual.*

Description

The sample draw aspirator adapter uses compressed air flowing through a venturi to draw air into a sample chamber.

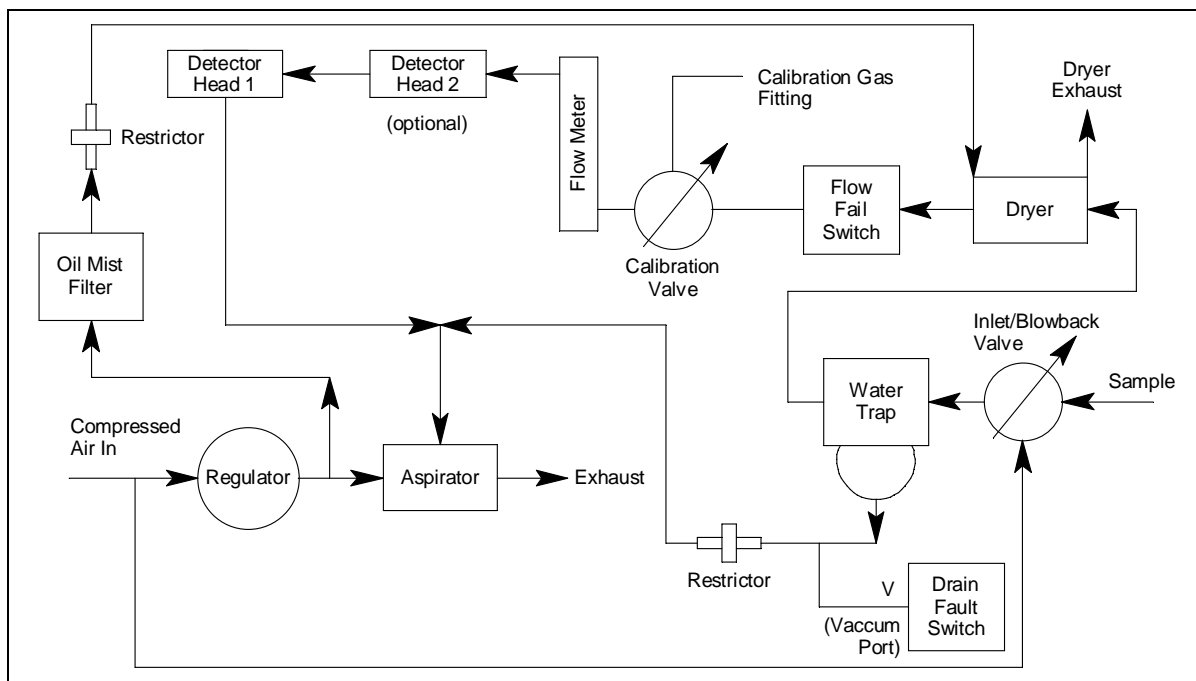

Figure 1: Flow Diagram

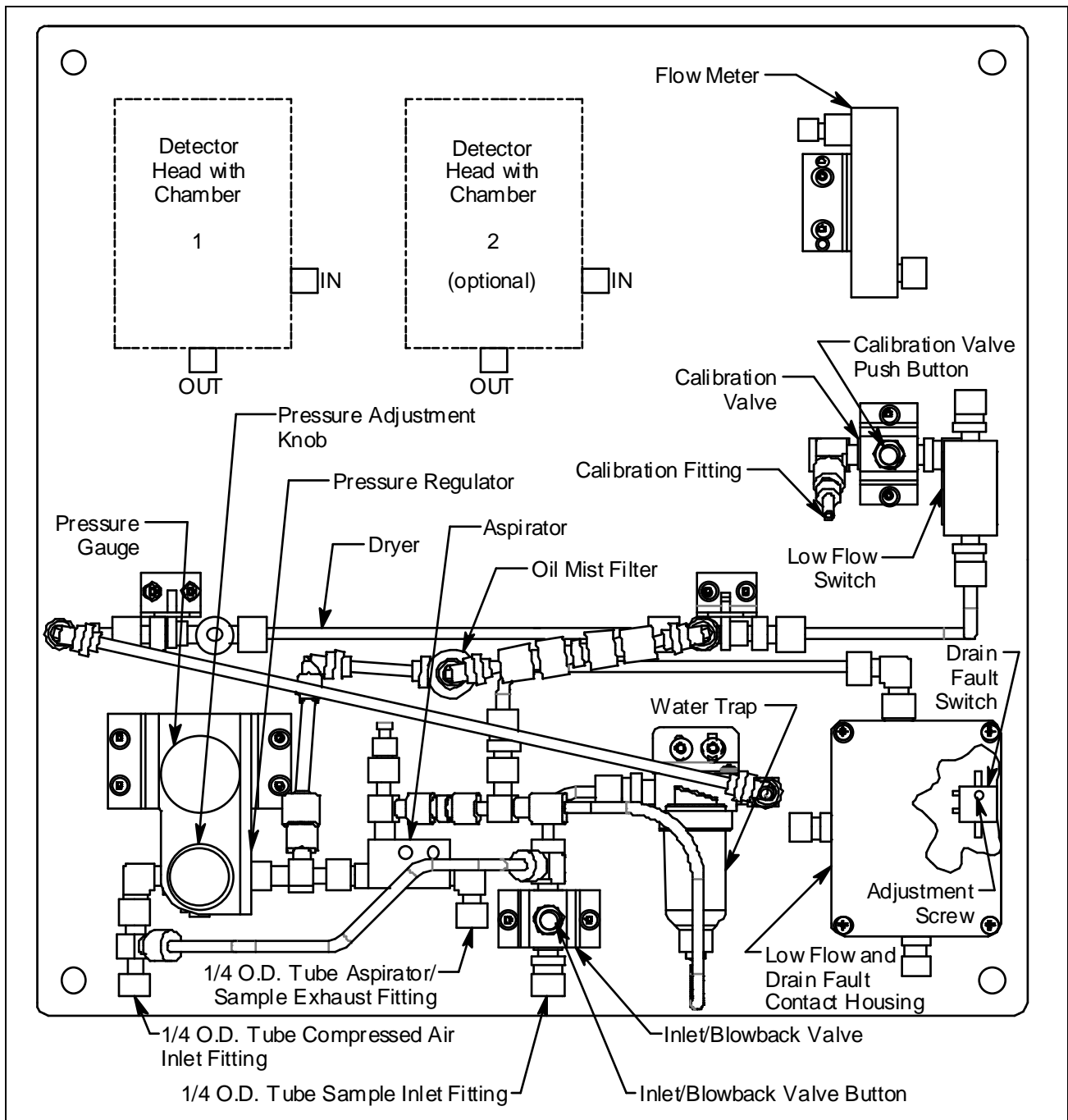

Figure 2: Component Location

The sample draw adapter consists of fourteen major components (see Figure 2): the detector head (1 or 2), regulator, aspirator, detector adapter, detector chamber (1 or 2), dryer, flowmeter, oil mist filter, calibration valve, inlet/blowback valve, water trap, low flow switch, drain fault switch, and low flow and drain fault contact housing.

Detector Head(s)

Each detector head provides a signal that can be used by a controller to indicate the sample gas level. Any RKI S Series, S2 Series, M2A, or direct connect detector head can be used with the sample drawing adapter plate. Figure 2 above shows the approximate location of the two detector heads. Please see the detector head operator's manual of the detector head(s) in your system for a complete description of the detector head(s).

Regulator

The regulator has an inlet port on its left side with a 1/4" tube fitting. The maximum allowable inlet pressure is 140 psi. A gauge at the bottom of the regulator indicates the output pressure. The output pressure, and detector flow, can be adjusted using the knob on the front of the regulator. The detector flow rises or falls as the output pressure is increased or decreased.

Aspirator

The aspirator inlet is connected to the output port on the right side of the regulator and the vacuum port on top is connected to the detector chamber. It has a venturi tube inside it which generates a vacuum at its top port when compressed air flows through it. The compressed air and the air drawn from the detector chamber into the top port of the aspirator both exhaust at the right side of the aspirator.

Detector Adapter

The detector adapter screws directly onto the detector. It is installed hand tight. Each specific sensor requires its own detector adapter. The detector adapter has a gasket or O-ring inside it which seals against the detector. When removing the detector adapter to replace the detector, be sure not to lose the gasket or O-ring. In the case of the catalytic LEL detectors, the gasket must be replaced when the detector is replaced.

Detector Chamber

The chamber has three thumbscrews which fasten it to the detector adapter. An O-ring at the top of the chamber seals the chamber/adapter interface. The inlet of the chamber is on the side and is connected to either the flowmeter exhaust or the detector chamber exhaust from another detector, depending on how many detectors are installed. The exhaust of the chamber is at the bottom and is connected to either the vacuum port of the aspirator or the detector chamber inlet of another detector, depending on how many detectors are installed.

Dryer

The dryer is located in the center of the sample-draw aspirator panel and removes any excess humidity in the sample before the sample enters the detector chamber(s).

Flowmeter

The flowmeter indicates the flow to the detector(s). It has a 1/4" OD tube fitting at its inlet and exhaust port. The exhaust port of the flow meter is connected to the detector chamber or to the first detector chamber if two detector heads are installed. The flowmeter's indication range is 1 - 10 SCFH. It has no flow adjustment valve because the flowrate is controlled by the regulator setting.

Oil Mist Filter

The oil mist filter is located in the center of the sample-draw aspirator panel and removes oil mist from the compressed air source before that air goes through the dryer.

Calibration Valve

The calibration valve is a manual operation spring return valve with a push button actuator. This valve is used to switch from sample flow to calibration gas during the calibration process. When the button is pushed and held, the sample port is closed and the calibration port is opened.

Inlet/Blowback Valve

The inlet/blowback valve is a manual operation spring return valve. A push button actuator is located on the front of the valve. This valve is used to switch from sample flow to blow back in the event of a clogged sample line. When the push button is pressed and held, the valve diverts the compressed air supply back through the sample line to clear obstructions.

WARNING: *The blowback pressure can be as high as 140 psi. Make sure that all personnel and equipment are clear of the sample line inlet end to avoid personal injury or equipment damage if a sample line obstruction is blown out of the sample line.*

Water Trap

The water trap prevents water from entering the flow system and is self-draining.

Low Flow/Drain Fault Contact Housing

The low flow switch provides open contacts in normal operation in the low flow/drain fault contact housing that close in the event of a low flow condition. Two contact wires protrude from the side of the switch and enter the low flow contact housing through a plastic cable bushing on the left side of the housing. Terminals are provided in the low flow/drain fault contact housing for field connection to the switch contacts.

The drain fault switch senses a break or very low flow in the water drain line and provides open contacts in normal operation in the low flow/drain fault contact housing which close when the switch senses a break, a very low drain flow, or a shut down.

Connecting monitoring devices to the low flow and drain fault contact terminals provides the user with a notification of a contact closure. Each set of contacts may have their own monitoring device or they may share one. See “Installation” on page 9 for instructions to wire these terminals using the two scenarios.

A second plastic cable bushing on the bottom of the low flow/drain fault contact housing allows for cable entry to the housing. The size range of the cable which can be routed through the second cable bushing is .064” - .210” OD.

Installation

This section describes how to mount, wire, and connect tubing to the 30-0954RK-200 Series.

Mounting

1. Install the mounting panel to a flat vertical surface using the four mounting holes (0.50" diameter) in the corners of the panel. Make sure that sufficient space is allowed to remove the detector head's cover, and to bring power/signal wiring to the detector head. Also provide sufficient clearance for routing of sample, compressed air, and exhaust lines. Mounting dimensions are shown below.

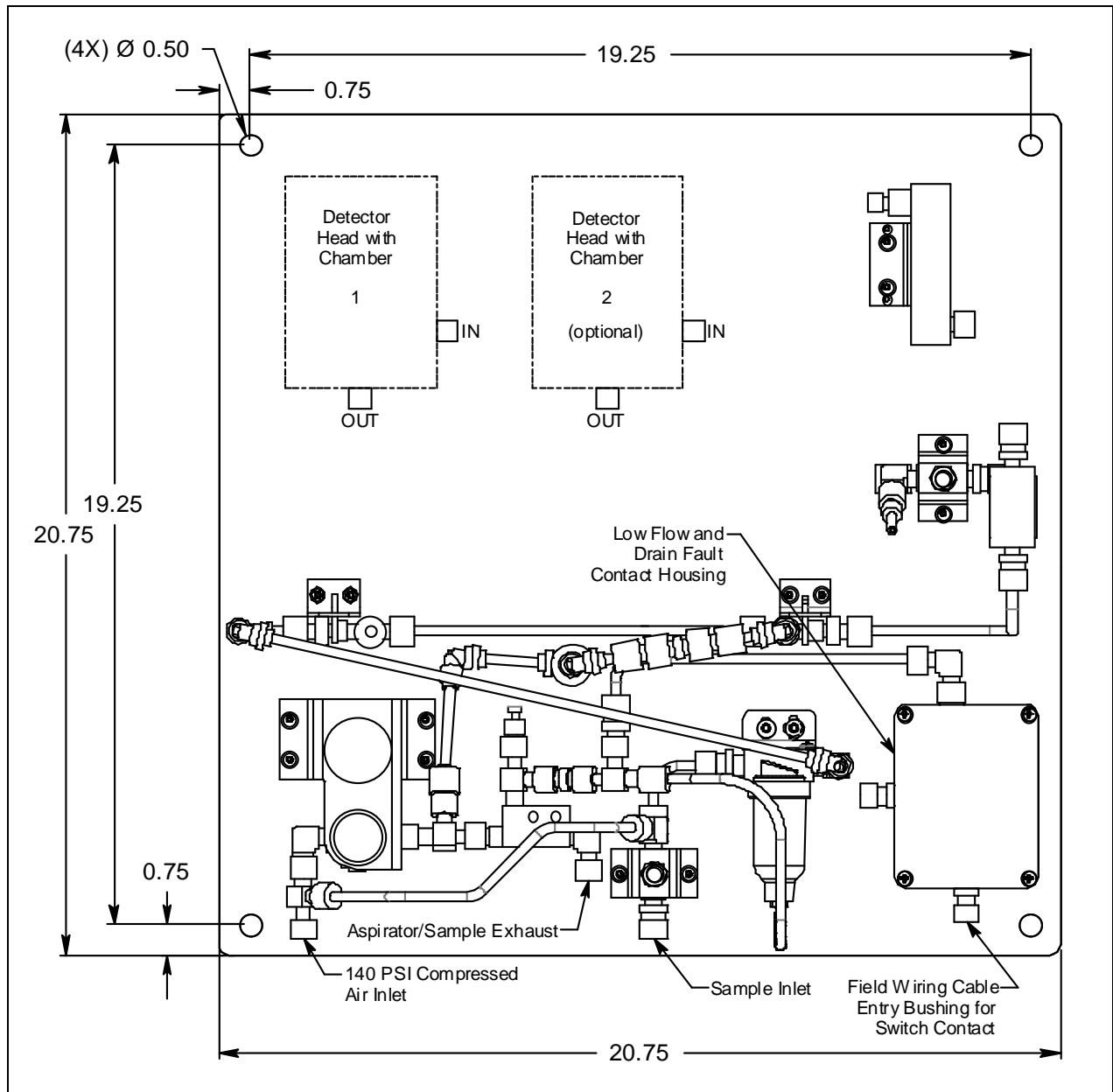

Figure 3: Outline & Mounting Dimensions

Wiring

1. Connect power/signal wiring to the detector head(s) as described in the detector head operator's manual.
2. Connect a contact monitoring device to the low flow and drain fault contact terminals inside the low flow and drain fault contact housing using the field wiring cable entry bushing.

The contacts may be wired individually or in parallel.

When wired individually, you will need one monitoring device for each set of contacts. When a specific monitoring device goes into alarm, you will immediately know which set of contacts closed and what the problem is.

When wired in parallel, only one monitoring device is needed to monitor both sets of contacts. However, when that device goes into alarm, it will be unclear which set of contacts closed without further investigation.

Wiring diagrams for each scenario are shown below.

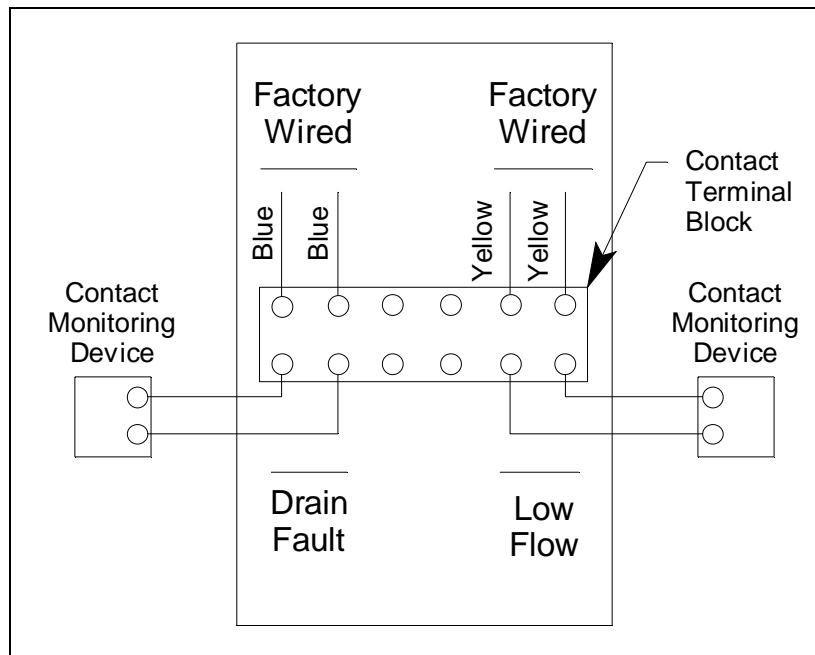

Figure 4: Low Flow and Drain Fault Wiring, Independent Wiring

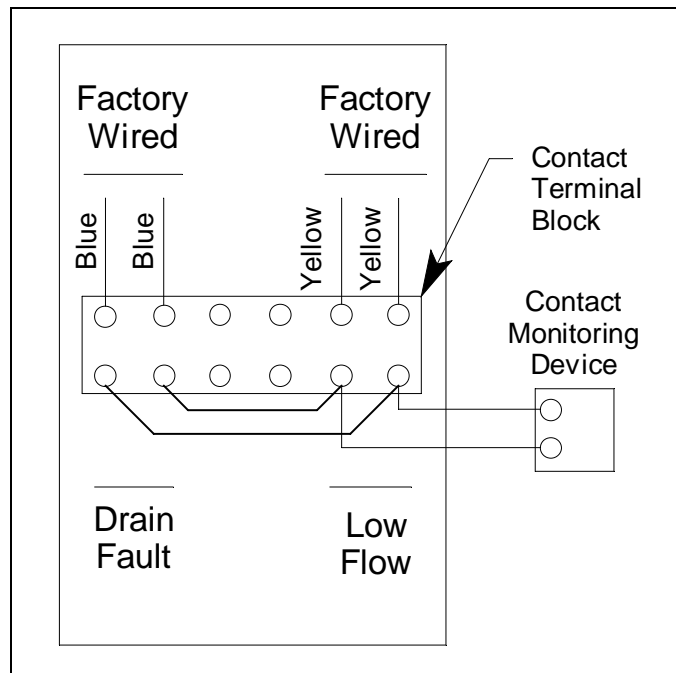

Figure 5: Low Flow and Drain Fault Wiring, Parallel Wiring

Tubing Connections

1. Connect a sample line from the area to be sampled to the sample inlet fitting at the bottom right of the panel. The fitting accepts 1/4" OD rigid metal tubing such as copper, aluminum, or stainless steel tubing. Be sure to use tubing appropriate for the target gas.

NOTE: If the sample draw aspirator adapter is installed in a cold area, the sample line will need to be heated in order to prevent condensation and possible freezing of the moisture in the gas sample line or sample draw aspirator adapter.

2. The aspirator exhaust includes the sample air. It may be routed to a different area where it can be exhausted safely by running tubing from the aspirator exhaust fitting to the "safe" area. The aspirator exhaust fitting is a 1/4" OD tubing fitting.
3. Turn the regulator adjustment knob completely counterclockwise and then turn it one turn clockwise so that the flow will start out at a low level when the compressed air is connected and turned on.
4. Connect a compressed air source up to a maximum of 140 psi to the inlet of the regulator. Although the regulator is rated up to 300 psi inlet pressure, other components are rated to a maximum of 140 psi.

NOTE: The compressed air used for the sample draw aspirator adapter must be dry (free from humidity). If wet air is used, at low temperatures, the moisture in the air may freeze in the aspirator and cause the sample draw aspirator adapter to function improperly.

Start Up

1. Start up the detector head(s) as described in the detector head operator's manual.
2. If necessary, turn on the compressed air source.
3. Adjust the regulator adjustment knob so that the flowmeter indicates 3 SCFH. The regulator exhaust pressure indicated by the regulator gauge will vary for a particular flow depending on the length of the sample line and other restrictions such as filters. Typically the pressure will be between 5 and 10 psi for short sample runs. It will be higher for longer sample runs and if filters are used.
4. Set the zero (fresh air) reading for the detector head(s) as described in the detector head operator's manual.

If you can verify a fresh air environment (environment free of combustible and toxic gases and of normal oxygen content, 20.9%) then you will not need to apply zero air to the detector head(s) before performing a zero (fresh air) adjustment.

If you cannot verify a fresh air environment (environment free of toxic and combustible gases and of normal oxygen content, 20.9%), you will need to apply zero air to the detector head(s) before performing a zero (fresh air) adjustment. Follow the steps in the Calibration section below.

Normal Operation

When the sample draw aspirator adapter is running in normal operation, sample is being routed through the detector chamber(s) at the flow rate shown by the flowmeter and controlled by the regulator.

See the detector head operator's manual for a description of the detector head's normal operation.

The low flow contacts are open during normal operation (flow above 1.6 SCFH). If the low flow switch senses a low flow condition in the sample flow (flow below 1.6 SCFH), it will close the low flow contacts located in the low flow/drain fault contact housing. The aspirator adapter will continue to draw sample even during a low flow condition.

The drain fault contacts are open during normal operation. If the drain fault switch senses a break or a very low flow in the drain line (likely caused by an object in the drain line), the drain fault contacts located in the low flow/drain fault contact housing will close. The aspirator adapter will continue to operate even during a drain fault condition.

Calibration

1. Follow the instructions in the detector head operator's manual for setting the zero (fresh air) reading and making span adjustments.
2. Apply gas using a gas bag filled with a fixed flow regulator or dispensing valve. See "Parts List" on page 18 for available parts. For toxic gas cylinders, like H₂S, it is important to vent the regulator while installing it onto the cylinder. Venting the regulator during installation helps prevent air from getting into the cylinder and degrading the gas. When filling the gas bag, open the regulator by turning the knob counterclockwise and then install it onto the cylinder.

NOTE: A gas bag is recommended for calibration instead of a demand flow regulator because a demand flow regulator introduces enough flow restriction to significantly reduce the flow. If a demand flow regulator is used, the flow will have to be adjusted up to 3 SCFH while the regulator is connected during calibration and down to 3 SCFH after calibration.

3. Connect the sample bag tubing to the hose barb calibration fitting on the calibration valve.
4. Push and hold the button on the calibration valve to start the flow of gas through the calibration gas fitting. If necessary, use the regulator adjustment knob to adjust the flowmeter to 3 SCFH.
5. Allow the sample draw adapter to draw sample for 2 minutes and then make any calibration adjustments necessary.
6. Release the push button on the calibration valve.
7. Disconnect the sample bag from the calibration fitting.

Maintenance

Blowback Operation

1. In the event of a clogged sample line, the blowback valve can be used to divert the compressed air supply back through the sample line to clear obstructions.
2. Inspect the sample line first to try to remedy the situation without using the blowback valve. If the line cannot be cleared, operate the blowback valve as described below.
3. Make sure that all personnel and equipment are clear of the inlet end of the sample line.
4. To operate the blowback valve, press and hold the button on the front of the blowback valve. As long as the button is held, compressed air will be applied to the sample line.

WARNING: *The blowback pressure can be as high as 140 psi. Make sure that all personnel and equipment are clear of the sample line inlet end to avoid personal injury or equipment damage if a sample line obstruction is blown out of the sample line.*

5. Release the button on the blowback valve. Verify that the sample is now flowing properly through the sample line.

Setting the Drain Fault Switch

The drain fault switch is factory set to detect a break in the drain line or very low drain flow from the water trap during operation. Under normal circumstances, it should not be necessary to adjust the drain fault switch in the field. If the drain fault switch contacts close to indicate a problem in the drain line and no cause can be determined, it may be necessary to adjust the drain fault switch. If the drain fault switch contacts are not operating properly, perform the following procedure to set the drain fault switch. If the drain fault switch contacts continue to operate improperly, contact RKI Instruments, Inc.

NOTE: In order to get an accurate open/close reading on the drain fault switch contacts, the low flow and drain fault switches must not be wired in parallel. Any monitoring device must also be disconnected from the drain fault switch contacts. Remove any jumpers and monitoring device wires from the drain fault switch contacts before setting the drain fault switch.

1. Ensure that the flowmeter reading is 3.0 SCFH.
2. Open the enclosure and connect an ohm meter to the drain fault switch terminals on the terminal block. Check that the contacts are open during normal operation.
3. Using the regulator, adjust the flow down until the flowmeter reads 1.0 SCFH.
4. Carefully adjust the drain fault switch using the adjustment screw until the contacts just close.
5. Adjust the flow back above 1.0 SCFH with the regulator and repeat step 3 until the contacts close between 0.8 and 1.0 SCFH. To increase the setpoint, turn the adjustment screw slightly counterclockwise. To decrease the setpoint, turn the adjustment screw slightly clockwise.
6. Adjust the flow back up above 1.0 SCFH. The contacts should reopen.
7. Adjust the flowrate to 3.0 SCFH.
8. Reconnect any wires that were removed before setting the drain fault switch. Refer to Figure 4 and Figure 5 for wiring diagrams.

Detector Replacement

1. Turn the regulator adjustment knob completely counterclockwise.
2. Loosen the thumbscrews that attach the detector chamber to the detector adapter.

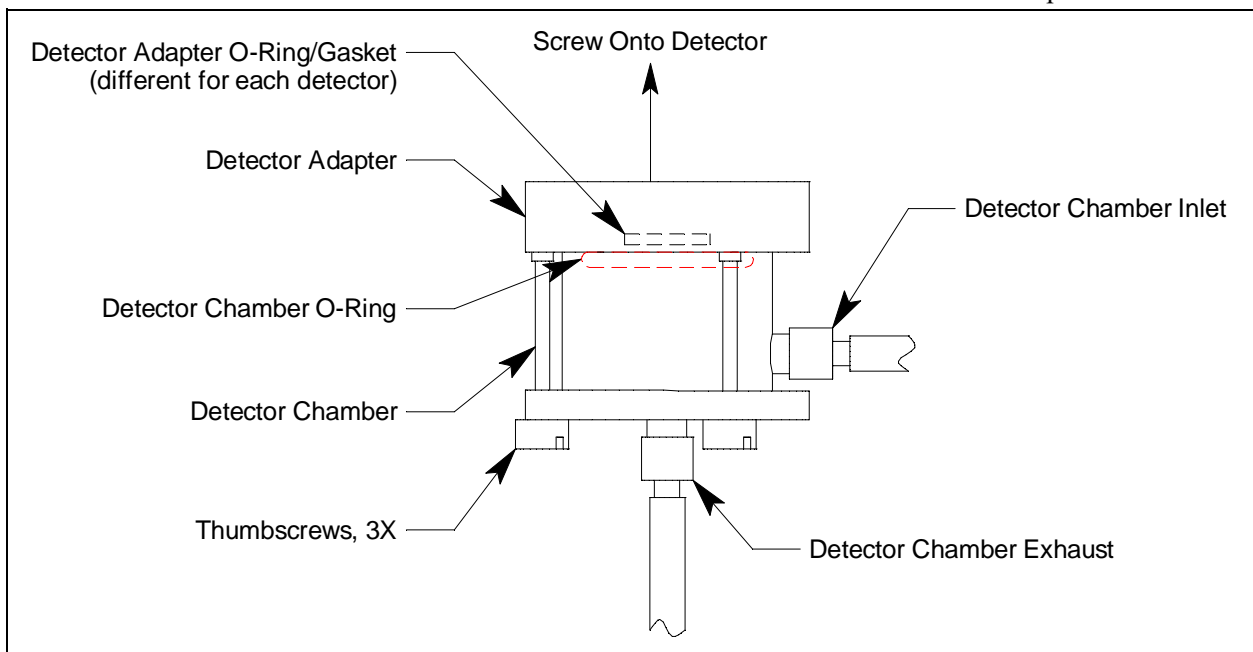

Figure 6: Detector Chamber/Detector Adapter Assembly

3. Pull the detector chamber away from the detector adapter and let it hang by its inlet and exhaust lines.
4. Grasp the detector adapter and unscrew it from the detector.

NOTE: Be sure not to lose the gasket/O-ring located between the detector adapter and the detector. In the case of the catalytic LEL detectors, the gasket must be replaced before installing the detector adapter back onto the detector.

5. Follow the instructions in the appropriate detector head manual for replacing a detector.
6. Insert a new O-ring/gasket into the top of the detector adapter.
7. Screw the detector adapter onto the new detector hand tight.
8. Reinstall the detector chamber into its appropriate position and tighten the thumbscrews.
9. Turn the regulator adjustment knob clockwise until the flowmeter indicates 3 SCFH.
10. Calibrate the detector.

Replacing the Water Trap's Filter Element

1. Turn the regulator adjustment knob completely counterclockwise.
2. Locate the water trap. It is in the lower right corner of the sample-draw aspirator panel.
3. Disconnect the black, flexible tubing from the bottom of the water trap.
4. Grasp the glass bowl of the water trap and unscrew it from the water trap lid. Be sure the O-ring that seals the glass bowl does not come out of the lid.
5. Unscrew the filter element holder from the water trap lid.
6. There is a circular, black deflector with a gasket on top of it that may come out when you remove the filter element holder. It has ridges along the outside edge. Do not lose the deflector or the gasket.
7. Remove the cylindrical water trap element.
8. Install a new filter element onto the filter element holder being sure that the grooved side of the element is facing down and gets inserted into the holder. The exposed end of the filter element should be smooth.
9. If the deflector and/or gasket came out when you removed the filter element holder, install the deflector on top of the filter element being sure that the deflector is curving down toward the filter element. Install the gasket over the deflector.
10. Screw the filter element holder back into the water trap lid.
11. Screw the glass bowl back into the water trap lid.
12. Reattach the black, flexible tubing to the bottom of the water trap.
13. Turn the regulator adjustment knob clockwise until the flowmeter indicates 3 SCFH.

Oil Mist Filter Replacement

1. Turn the regulator adjustment knob completely counterclockwise.
2. Locate the oil mist filter. It is located in the middle of the sample-draw aspirator panel.

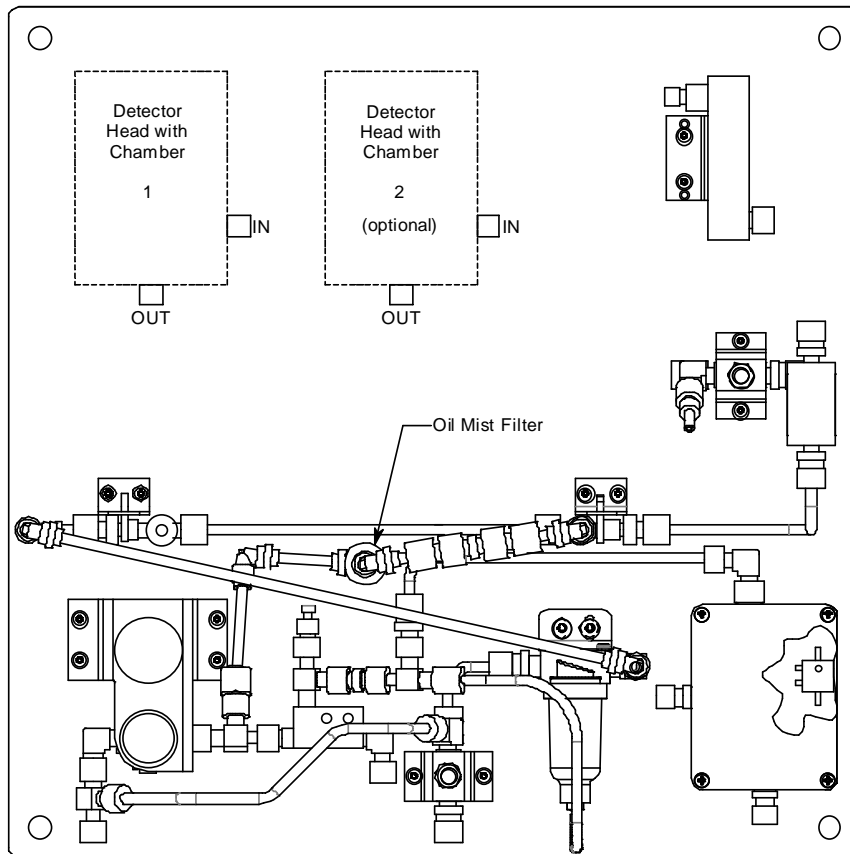

Figure 7: Oil Mist Filter Location

3. The oil mist filter must be removed from the flow system with the push fittings attached because pliers are needed to remove the push fittings from the oil mist filter.
4. Grasp one of the white, right angle push fittings on the ends of the oil mist filter. Press the collet toward the fitting and pull the fitting away from the flow system. Repeat with the other right angle push fitting. The oil mist filter with fittings still connected can now be removed.

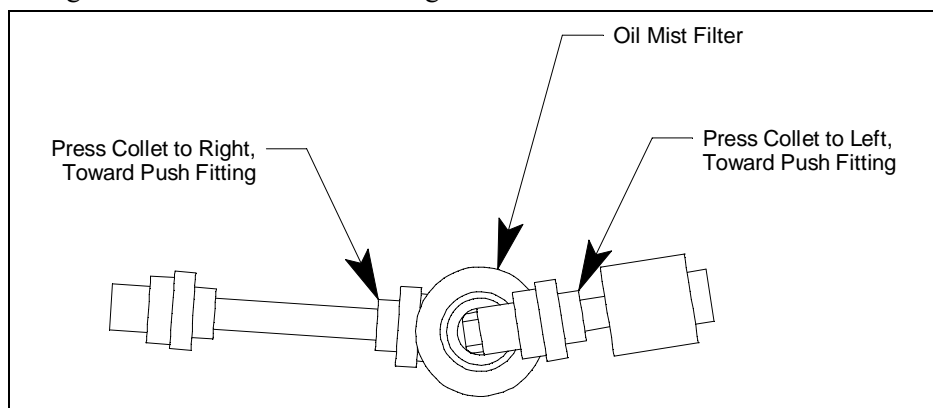

Figure 8: Removing the Oil Mist Filter from the Flow System

5. Use needle nose pliers to press down on the collet of each connected push fitting and remove the fittings from the oil mist filter. Discard the old oil mist filter but be sure to keep the push fittings that were removed.

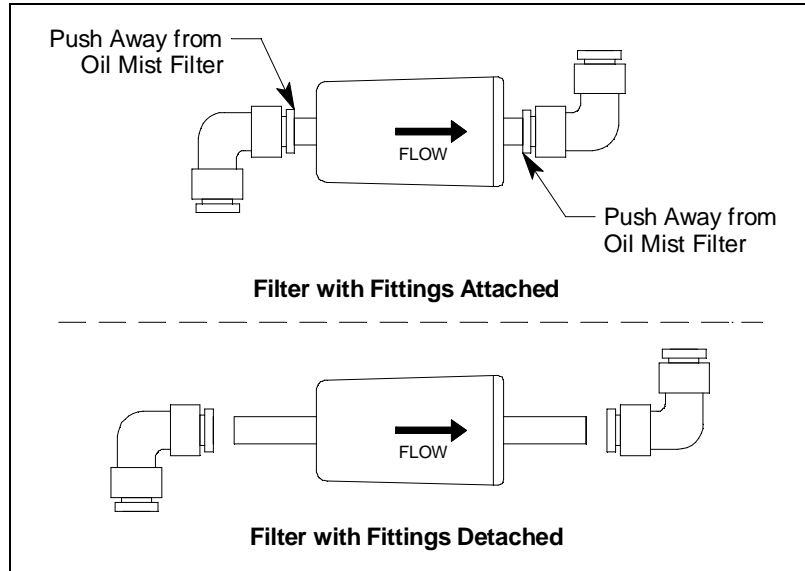

Figure 9: Removing the Fittings from the Oil Mist Filter

6. Press one of the white, right angle push fittings onto the new oil mist filter's barb. Repeat with the other fitting.
7. Install the new oil mist filter and fitting assembly into the flow system by connecting the push fittings to the open rigid tubing. The arrow on the filter should be pointing away from the sample-draw aspirator's panel.
8. Turn the regulator adjustment knob clockwise until the flowmeter indicates 3 SCFH.

Parts List

Table 2 lists replacement parts and accessories for the sample draw adapter.

Table 2: Parts List

Part Number	Description
06-1248RK-03	Tubing, 3/16 x 5/16, polyurethane, 3 foot length, for calibration kit
07-0107RK	Gasket for catalytic LEL type detector adapter
07-7123RK	O-ring for replaceable sensor and CSA LEL type detector adapter
07-7218RK	O-ring, for 3/4 NPT type detector adapter
07-7225RK	O-ring, for detector chamber
13-1070RK	Captive panel screw, 10-32 x 1.75
33-0164RK	Oil mist filter
33-0413RK-02	Filter element for water trap
33-0413RK-10	Water trap
81-1001RK	Dispensing valve, for 34 liter steel cylinders
81-1051RK-60	Regulator with gauge and knob, 6 LPM, for 34 liter aluminum cylinder, 58 liter cylinder, and 103 liter cylinder
81-1127RK	Gas bag with fittings and hosebarb, 12 inches x 12 inches, 5 liters, tedlar