

01 Series Operator's Manual

Part Number: 71-0093RK

Revision: A

Released: 2/2/11

WARNING

Read and understand this instruction manual before operating instrument. Improper use of the gas monitor could result in bodily harm or death.

Periodic calibration and maintenance of the gas monitor is essential for proper operation and correct readings. Please calibrate and maintain this instrument regularly! Frequency of calibration depends upon the type of use you have and the sensor types. Typical calibration frequencies for most applications are between 1 and 3 months, but can be required more often or less often based on your usage.

Warranty

RKI Instruments, Inc. warrants the 01 Series Single Gas Monitor sold by us to be free from defects in materials, workmanship, and performance for a period of two (2) years from the date of shipment from RKI Instruments, Inc. This includes the instrument and the original sensor. Replacement parts are warranted for one (1) year from the date of their shipment from RKI Instruments, Inc. Any parts found defective within their warranty period will be repaired or replaced, at our option, free of charge. This warranty does not apply to those items, which by their nature, are subject to deterioration or consumption in normal service, and which must be cleaned, repaired, or replaced on a routine basis. Examples of such items are as follows:

Absorbent cartridges

Filter elements, disks, or sheets

Pump diaphragms and valves

Warranty is voided by abuse including mechanical damage, alteration, rough handling, or repair procedures not in accordance with the instruction manual. This warranty indicates the full extent of our liability, and we are not responsible for removal or replacement costs, local repair costs, transportation costs, or contingent expenses incurred without our prior approval.

THIS WARRANTY IS EXPRESSLY IN LIEU OF ANY AND ALL OTHER WARRANTIES AND REPRESENTATIONS, EXPRESSED OR IMPLIED, AND ALL OTHER OBLIGATIONS OR LIABILITIES ON THE PART OF RKI INSTRUMENTS, INC. INCLUDING BUT NOT LIMITED TO THE WARRANTY OF MERCHANTABILITY OR FITNESS FOR A PARTICULAR PURPOSE. IN NO EVENT SHALL RKI INSTRUMENTS, INC. BE LIABLE FOR INDIRECT, INCIDENTAL, OR CONSEQUENTIAL LOSS OR DAMAGE OF ANY KIND CONNECTED WITH THE USE OF ITS PRODUCTS OR FAILURE OF ITS PRODUCTS TO FUNCTION OR OPERATE PROPERLY.

This warranty covers instruments and parts sold to users only by authorized distributors, dealers, and representatives as appointed by RKI Instruments, Inc.

We do not assume indemnification for any accident or damage caused by the operation of this gas monitor and our warranty is limited to replacement of parts or our complete goods.

Table of Contents

Introduction	1
Specifications	2
Description	4
Protective Rubber Boots	5
Case	5
Alligator & Belt Clips	6
Membrane Retainer/Sensor Cover	6
Charcoal Filter Disk in CO-01	6
Sensor Retainer	7
Sensor	7
LCD	7
Control Buttons	8
Printed Circuit Boards	8
Alarm Lights	9
Buzzer	9
Vibrator	9
Batteries	9
Start Up	10
Start-up Procedure	10
Performing a Fresh Air Adjustment	10
Turning Off the 01 Series	10
Operation	11
Measuring Mode	11
Displaying the Peak, STEL, and TWA (CO-01 and HS-01)	11
Displaying the Min and Max (OX-01)	12
Alarms	13
Alarm Points	16
Displaying and Adjusting the Alarm Points	16
Calibration	19
Calibration Frequency	19
Setting the Fresh Air Reading	19
Setting the Span Reading	19

Maintenance **22**
 Troubleshooting 22
 Replacing the Batteries 23
 Replacing the Sensor 24
 Replacing the Sensor Cover and Charcoal Filter 25
Parts List **27**

WARNING: Understand this manual before operating the 01 Series. Substitution of components may impair intrinsic safety. To prevent ignition of a hazardous atmosphere, batteries must only be changed in an area known to be nonhazardous. This unit has not been tested in an oxygen enriched atmosphere (above 21%).

Introduction

Using an advanced microprocessor controlled detection system, the 01 Series Personal Single Gas Monitor detects the presence of either carbon monoxide (CO), hydrogen sulfide (H₂S), or oxygen (O₂). The 01 Series's compact size and easy-to-use design makes it ideally suited for a wide range of applications, including sewage treatment plants, tunnels, hazardous waste sites, petrochemical facilities, oil fields, mines, and chemical plants. The 01 Series is even small enough to be placed conveniently in a pocket. The 01 Series offers the following features:

- Compact design
- Fast, accurate response with digital liquid crystal display (LCD)
- Visual, audible, and vibration alarms
- Microprocessor control for reliability, ease of use, and advanced capabilities
- Peak, STEL, and TWA indication for CO-01& HS-01
- Minimum and maximum indication for OX-01
- Over range alarm
- Gas, battery, sensor failure, and system failure alarms
- Over 3,000 hours operation on one set of alkaline batteries
- CSA certified for intrinsic safety in Class I, Division I, Groups A, B, C, and D hazardous atmospheres
- Low temperature operation down to -40 °C with the HS-01S

WARNING: The 01 Series detects oxygen deficiency and elevated levels of oxygen, carbon monoxide, and hydrogen sulfide, all of which can be dangerous or life threatening. When using the 01 Series, you must follow the instructions and warnings in this manual to assure proper and safe operation of the unit and to minimize the risk of personal injury. Be sure to maintain and periodically calibrate the 01 Series as described in this manual.

Specifications

Table 1: 01 Series Specifications

	CO-01	HS-01/HS-01S	OX-01
Target Gas	Carbon Monoxide (CO)	Hydrogen Sulfide (H ₂ S)	Oxygen (O ₂)
Detection Range	0 to 500 ppm	0 to 100.0 ppm	0 to 40.0% vol.
Display Increment	1 ppm	0.5 ppm	0.1% vol.
Detection Principle	Electro Chemical	Electro Chemical	Galvanic Cell
Alarm Points	Low 25 ppm High 50 ppm TWA 25 ppm STEL 200 ppm	Low 10.0 ppm High 30.0 ppm TWA 10.0 ppm STEL 15.0 ppm	Low 19.5% vol. (decreasing) High 23.5% vol. (increasing)
Sampling Method	Diffusion	Diffusion	Diffusion
Response Time	T90 in 30 seconds	T90 in 30 seconds	T90 in 20 seconds
Accuracy	± 5% of reading or ± 5 ppm CO (whichever is greater)	± 5% of reading or ± 2 ppm H ₂ S (whichever is greater)	± 0.5% O ₂
Indication	7-Segment Digital LCD		
Safety/Regulatory	 C US 186718 CSA classified, "C/US", as Intrinsically Safe. Exia. Class I, Groups A, B, C, & D. Temperature Code T3.		
Power	Two AAA size Alkaline Batteries Standard, Duracell MN2400 or PC2400, Eveready Energizer E92 or EN92		
Continuous Operating Hours	<ul style="list-style-type: none"> At 25 °C, All Models: Over 3,000 Hours, No Alarms or Backlighting At -40 °C, HS-01S: 1,500 Hours, No Alarms or Backlighting 		
Case	High-impact Plastic, Dust and Weather Proof		
Standard Accessories	<ul style="list-style-type: none"> Wrist Strap Rubber protective boots 		

Table 1: 01 Series Specifications

	CO-01	HS-01/HS-01S	OX-01
Optional Accessories	<ul style="list-style-type: none">• Calibration Adapter• Calibration Kit• Alligator Clip• Belt Clip		
Dimensions and Weight	1.4" (35mm) W x 4.1" (104mm) H x 0.8" (20mm) D; 3.5 oz. (100 g)		
Operating Temp. & Humidity	<ul style="list-style-type: none">• CO/HS/OX-01: -20°C to +50°C, below 90% RH (non condensing)• HS-01S: -40°C to +50°C, below 90% RH (non condensing)		

Description

This section describes the components of the 01 Series. These components include the 01 Series' protective rubber boots, case, membrane retainer and filter disks, sensor retainer, sensor, LCD, control buttons, printed circuit boards, alarm lights, buzzer, vibrator, and batteries.

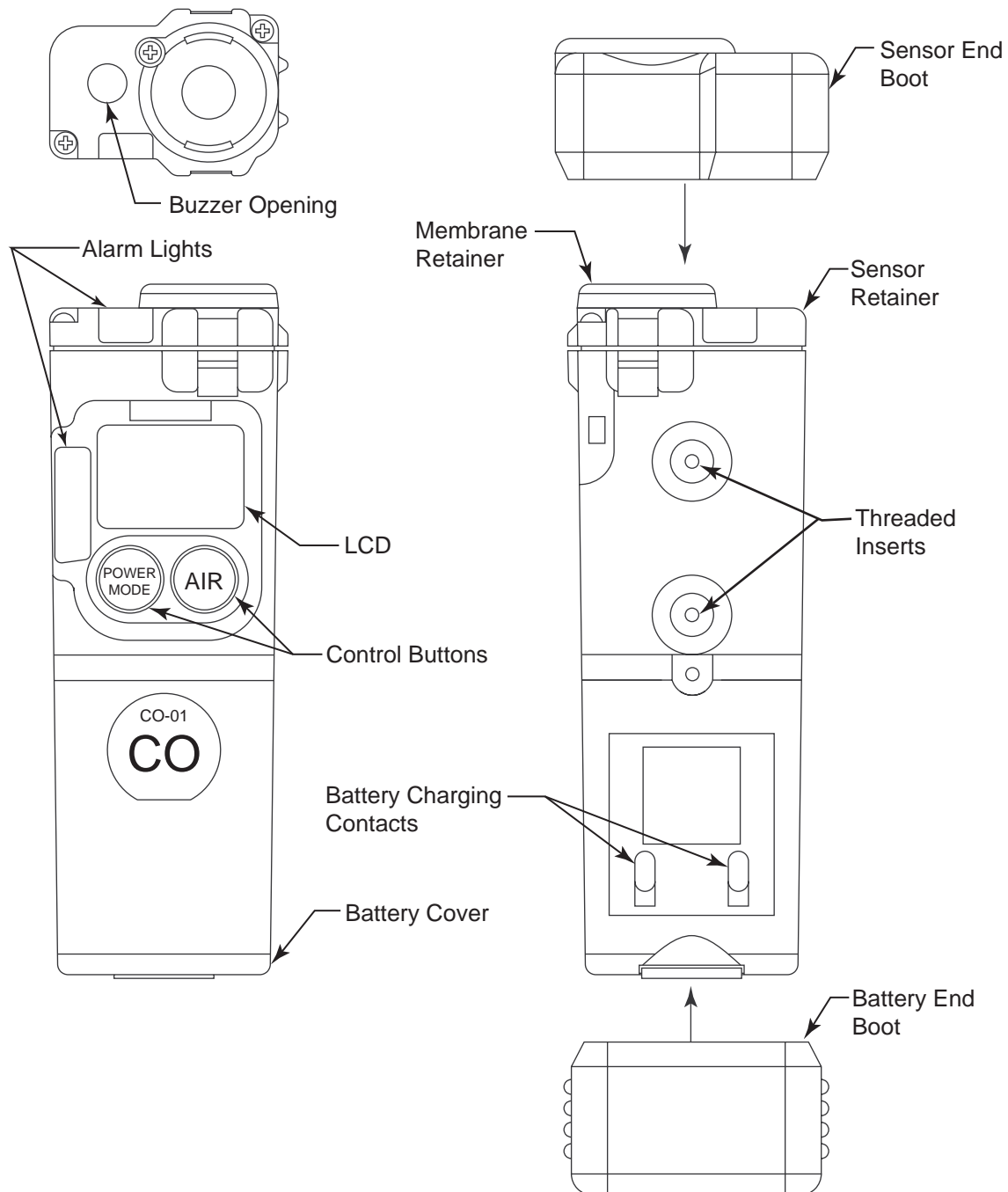

Figure 1: Components of the 01 Series

Protective Rubber Boots

A protective rubber boot is installed over each end of the 01 Series. The sensor end boot fits over the sensor cover end of the 01 Series and the battery end boot fits over the battery cover end of the 01 Series.

Case

The 01 Series' sturdy, high-impact plastic case is blue in color. The case is suitable for use in many environmental conditions, indoors and out. The unit is dust proof and weather resistant.

The front of the case has an LCD (liquid crystal display) that shows various readings, which are described under "LCD" in this section. To the left of the LCD is an alarm light. Below the LCD are two black control buttons. The left button is labeled "POWER/MODE" and the right button is labeled "AIR".

On top of the case and to the left is the 01 Series's buzzer, which is located inside the unit. To the right of the buzzer is the sensor. The sensor is held in place by the sensor retainer (the top of the case for the 01 Series) and two screws. The sensor is protected from dirt and moisture by the sensor cover. The sensor cover is secured by a membrane retainer and a single screw. In the case of the CO-01, a charcoal filter is provided under the sensor cover to protect the CO sensor from hydrogen sulfide and certain hydrocarbons. To the left of the sensor and below the buzzer, is a second alarm light, which is also visible from the front of the case.

The battery compartment is located on the bottom of the case. Access to the compartment is accomplished by turning the captive battery cover screw counterclockwise and by removing the battery compartment door.

There are two threaded holes on the back of the case. These are used to mount the optional alligator clip or belt clip.

Toward the bottom of the back are two battery charging contacts. These contacts are used to charge a Ni-cad battery pack which is available. Consult RKI Instruments, Inc. for information about this option.

The wrist strap connects to the back of the case on the left side, near the top of the unit.

Alligator and Belt Clips

The 01 Series is available with two types of clips, the alligator clip and the belt clip. Both are illustrated in Figure 2 below.

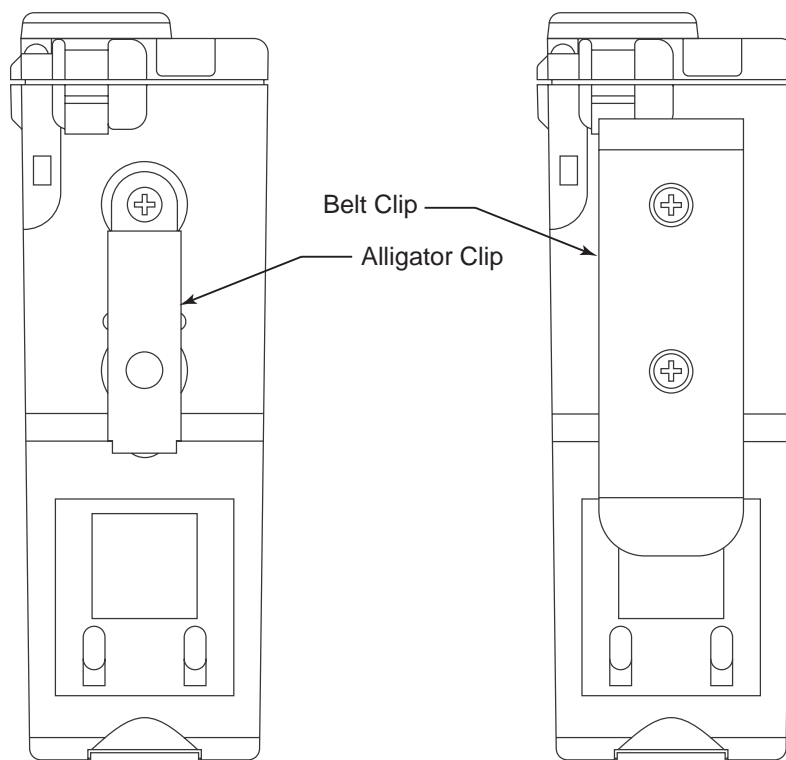

Figure 2: Alligator & Belt Clips

The alligator clip can be used to attach the 01 Series to clothing or a belt. Teeth in the clip's jaws prevent the unit from slipping off. The belt clip is used to easily clip the 01 Series on a belt.

Membrane Retainer/Sensor Cover

The membrane retainer is held in place by a single Phillips screw. Beneath the membrane retainer is a paper-like filter disk, the sensor cover. The sensor cover protects the sensor from dirt and moisture.

The sensor cover fits into a recessed area and is held in place by the membrane retainer. The sensor cover should be inspected periodically and replaced if contaminated by dirt or moisture. Refer to the Maintenance section for sensor cover replacement instructions.

Charcoal Filter Disk in CO-01

The CO-01 includes a charcoal filter disk which is located in a recessed area beneath the sensor cover. The charcoal filter disk removes gases from the sampled air that will cause a response on the CO sensor such as H₂S and certain hydrocarbons. If false or elevated CO readings are

noticed, especially in the presence of H₂S, change the charcoal filter disk (see the Maintenance section for instructions).

Sensor Retainer

The sensor retainer holds the sensor in place. It is attached to the top of the case by two Phillips screws. The sensor retainer also covers the buzzer.

Should the sensor require replacement, refer to the Maintenance section for sensor replacement instructions. The buzzer, however, is *not* field replaceable.

The sensor retainer has a single diffusion port through which ambient air reaches the sensor. Recessed areas in the sensor retainer accept the charcoal filter disks (CO-01 only) and the sensor cover. The membrane retainer is installed to the top of the sensor retainer with a single Phillips screw.

Sensor

The 01 Series uses either an oxygen, CO, or H₂S sensor. The sensor is protected by the white sensor cover which is held in place by the membrane retainer. The sensor cover allows ambient air to diffuse past it to the sensor. The three sensors used in the three 01 Series models use different detection principles as described below.

Oxygen Sensor

The oxygen sensor is a galvanic type of sensor. A membrane covers the cell and allows gas to diffuse into the cell at a rate proportional to the partial pressure of oxygen. The oxygen reacts in the cell and produces a voltage proportional to the concentration of oxygen. The voltage is measured by the 01 Series' circuitry, converted to a measurement of gas concentration, and displayed on the LCD.

CO and H₂S Sensors

The CO and H₂S sensors are electrochemical sensors that consist of two precious metal electrodes in an acid electrolyte. A gas permeable membrane covers the sensor face and allows gas to diffuse into the electrolyte. The gas reacts in the sensor and produces a current proportional to the concentration of the target gas. The current is amplified by the 01 Series' circuitry, converted to a measurement of gas concentration, and displayed on the LCD.

LCD

The LCD is visible through the front of the case. When the 01 Series is in Measuring Mode, the target gas concentration, battery condition, and alarm indications are displayed on the LCD. Various other items are displayed when the LCD is in other modes, such as Calibration Mode.

When either of the two control buttons are pressed, the LCD backlight comes on for 20 seconds.

Control Buttons

Below the LCD are two control buttons: POWER/MODE and AIR. The POWER/MODE button turns the 01 Series on and off. The functions performed by the control buttons are summarized in the following table:

Table 2: 01 Series Control Buttons

Button	Function
POWER/MODE	<ul style="list-style-type: none"> • Turns the unit on and off. • Turns the LCD back light on. • Displays STEL and TWA readings (HS-01 & CO-01). • Displays peak readings (high for HS-01& CO-01and low & high for OX-01). • Resets the alarm circuit (gas alarms). • Enters Calibration Mode with the AIR button. • Enters Alarm Adjustment Mode with the AIR button.
AIR	<ul style="list-style-type: none"> • Turns the LCD back light on. • Adjusts LCD readings when the fresh air adjustment is performed. • Enters Calibration Mode with the POWER/MODE button. • Enters Alarm Adjustment Mode with the POWER/MODE button. • Increases settings when the unit is in Alarm Adjustment Mode or Calibration Mode.

Printed Circuit Boards

The primary function of the 01 Series's printed circuit boards is to amplify the signal sent to them from the sensor, convert the signal to a meaningful measurement of gas concentration, display the gas concentration on the LCD, store STEL, TWA, and peak gas readings, and activate the alarm circuit if an alarm point has been reached. They monitor battery level, battery failure, and sensor failure. They also control various operating modes of the unit.

NOTE: The printed circuit boards contain no user serviceable parts.

Alarm Lights

The 01 Series has two red LED alarm lights. They alert you to gas, low battery, and sensor failure alarms. The smaller of the two lights is square, has a frosted plastic cover, and is located at the top of the unit to the left of the membrane retainer. The larger alarm light is rectangular in shape, has a diamond-grid pattern etched into the plastic cover, and is located to the left of the LCD on the front of the case.

Buzzer

A solid-state electronic buzzer is mounted inside the 01 Series. An opening in the sensor retainer on top of the case allows the buzzer's sound to emanate from the case. The buzzer sounds for gas alarms, unit malfunctions, and dead battery alarm. It also serves as an indicator during normal use of the various LCD display options.

Vibrator

A vibrating motor (vibrator) is mounted inside the 01 Series. The vibrator vibrates momentarily during the power-up sequence and for gas alarms.

Batteries

Two AAA-size alkaline batteries run the 01 Series. At 25°C the alkaline batteries last at least 3,000 hours. The battery icon on the LCD shows remaining battery life.

When the 01 Series detects low battery voltage, a low battery warning is activated. When battery voltage is too low for normal operation, the 01 Series sounds a dead battery alarm.

The alkaline batteries can be replaced by removing the battery door at the bottom of the case. Turn the captive battery cover screw counterclockwise to release the door.

WARNING: To prevent ignition of a hazardous atmosphere, batteries must only be changed in an area known to be nonhazardous.

A Ni-cad battery pack and charger are available. Contact RKI Instruments, Inc. for information about this option.

Start Up

This section explains how to start up the 01 Series and to get it ready for operation.

Start-up Procedure

1. Press and hold the POWER/MODE button for three seconds to turn on the 01 Series.

For several seconds, all elements of the LCD display and the LCD backlight turn on. The vibrator activates briefly, and it then shuts off. The alarm lights flash on and the buzzer sounds, and then they both turn off.

2. The 01 Series then displays the target gas (H₂S, CO, or O₂) before displaying the battery voltage. The buzzer sounds again after the battery voltage is displayed.

CAUTION: *If the unit gives a low battery warning or dead battery alarm, change the alkaline batteries before using the unit.*

3. The sensor inside the 01 Series begins operating and the concentration of the target gas is displayed on the LCD. The 01 Series is now in Measuring Mode. The target gas concentration is displayed. The backlight turns off after 20 seconds.

Performing a Fresh Air Adjustment

Before using the 01 Series, set the fresh air reading. Performing this adjustment ensures accurate gas readings in the monitoring environment.

1. Find a fresh air environment of normal oxygen content (20.9%) that is free of toxic or combustible gases.
2. With the unit on and in Measuring Mode, press and hold the AIR button. The LCD displays “hold” prompting you to hold the AIR button.
3. Release the AIR button when the LCD displays “AdJ”. The unit will set the reading to 0 ppm (20.9% for the OX-01) and return to Measuring Mode.

Turning Off the 01 Series

1. Press and hold the POWER/MODE button for about five seconds to turn off the unit. The buzzer will sound while the POWER/MODE button is being pressed before the unit turns off.
2. Release the button when the LCD is blank. The unit is off.

Operation

This section describes the normal operation of the 01 Series in Measuring Mode. It explains how the unit can be used to display peak, STEL, and TWA readings for the HS-01 and CO-01, and minimum and maximum readings for the OX-01. It also covers alarm indications.

Measuring Mode

To put the 01 Series in Measuring Mode, assuming the unit is off, press and hold the POWER/MODE button for three seconds.

Before continuing, it is advisable to perform a fresh-air adjustment in a fresh-air environment. Making this adjustment ensures accurate gas readings in the monitoring environment. Refer to “Start Up” for more information.

In Measuring Mode, the battery level and target gas concentration are displayed on the LCD. The battery icon has four bars visible when the batteries have a full charge. As the battery charge decreases, the bars will gradually disappear, one by one.

The target gas concentration is displayed below the battery icon. On the CO-01, CO is displayed in parts per million (ppm). On the HS-01, H₂S is displayed in ppm. On the OX-01, oxygen is displayed as volume percent

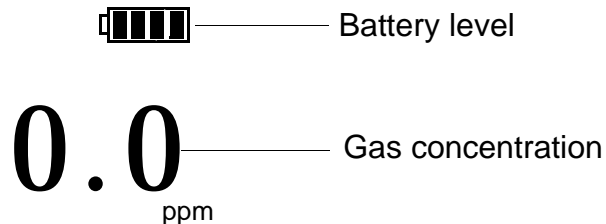

Figure 3: LCD in Measuring Mode

Displaying the Peak, STEL, and TWA (CO-01 & HS-01)

You can display the Peak, STEL, and TWA readings on the CO-01 and HS-01 when the 01 Series is in Measuring Mode using the POWER/MODE button. STEL is an acronym for short-term exposure limit, and it is the average reading of the target gas (H₂S or CO) during the last 15 minutes. TWA is an acronym for time-weighted average, and it is the average reading for the target gas (H₂S or CO) during the last eight (8) hours. If eight (8) hours has not elapsed since the unit was turned on, the TWA is still calculated over eight hours, with the missing time assigned a zero (0) value for the readings. Similarly, if the unit has not been on for 15 minutes, the missing time is assigned a 0 value and the STEL is calculated over 15 minutes. The Peak, STEL, and TWA readings are cleared when the unit is turned off.

1. The unit must be in Measuring Mode. The current gas concentration should be displayed on the LCD.
2. Press and release the POWER/MODE button to enter Peak Gas Display Mode. The LCD backlight will activate and the LCD will display the peak gas reading. A small peak symbol is displayed in the upper left corner of the LCD.
3. Press and release the POWER/MODE button again to enter STEL Display Mode. This will display the STEL reading. The word "STEL" is displayed in the middle of the LCD above the reading.
4. Press and release the POWER/MODE button again to enter TWA Display Mode. This will display the TWA reading. The word "TWA" is displayed in the middle of the LCD above the reading.
5. Press and release the POWER/MODE button once again to return the unit to Measuring Mode.

NOTE: If you do not press a button for 20 seconds while displaying the peak gas reading, the unit will return to Measuring Mode automatically and the backlight will turn off.

Displaying the Min and Max (OX-01)

You can display the minimum (Min) and maximum (Max) readings on the OX-01 when the it is in Measuring Mode using the POWER/MODE button. The Min and Max readings are cleared when the unit is turned off.

1. Make sure the OX-01 is in Measuring Mode. The oxygen concentration should be displayed on the LCD.
2. Press and release the POWER/MODE button to enter Min Display Mode. This will activate the LCD backlight and display the Min reading. A small Min symbol is displayed in the upper left corner of the LCD.
3. Press and release the POWER/MODE button again to enter Max Display Mode. This will display the Max reading. A small Max symbol is displayed in the upper left corner of the LCD.
4. Press and release the POWER/MODE button once again to return to Measuring Mode.

NOTE: If you do not press a button for 20 seconds while displaying the Min or Max readings, the unit will return to Measuring Mode automatically and the backlight will turn off.

Alarms

This section covers alarm indications. It also tells you how to reset the 01 Series after an alarm has occurred and how to respond to an alarm condition.

Alarm Indications

The 01 Series will sound an alarm, flash its alarm lights, and vibrate when the target gas concentration rises above the low alarm point. The 01 Series also sounds an alarm, flashes its alarm lights, and vibrates when the high alarm point is reached. In addition, the 01 Series also has a low battery warning, a dead battery alarm, an over range alarm, a sensor failure alarm, and a system failure alarm. See Table 3 below for a description of each alarm indication.

Table 3: Alarm Types and Indications

Alarm Type	LCD Indications	Other Indications
<p>Low Alarm Concentration of gas rises above the low alarm point, or for the OX-01, falls below the low alarm point.</p>	<ul style="list-style-type: none"> Gas reading flashes. Back light turns on. 	<ul style="list-style-type: none"> Pulsing tone occurs once per second. Unit vibrates once per second. Alarm lights flash once per second.
<p>High Alarm Concentration of gas rises above the high alarm point.</p>	<ul style="list-style-type: none"> Gas reading flashes. Back light turns on. 	<ul style="list-style-type: none"> Pulsing tone occurs twice per second. Unit vibrates twice per second. Alarm light flashes twice per second.
<p>TWA or STEL (CO-01 & HS-01 Only) Concentration of CO or H₂S rises above the TWA or STEL alarm point.</p>	<ul style="list-style-type: none"> Back light turns on. Gas reading flashes. TWA or STEL blinks to the left of the battery icon. If the unit is in both TWA alarm and STEL alarm, both TWA and STEL will be displayed. 	<ul style="list-style-type: none"> Pulsing tone once per second. Unit vibrates once per second. Alarm light flashes once per second.

Table 3: Alarm Types and Indications

Alarm Type	LCD Indications	Other Indications
<p>Over Range Concentration of gas rises above the measuring limit of the 01 Series. (Or there could be a problem with the unit.)</p>	<ul style="list-style-type: none"> • Gas reading replaced by blinking brackets. □□□□ • Back light turns on. 	<ul style="list-style-type: none"> • Pulsing tone occurs once per second. • Unit vibrates once per second. • Alarm light flashes.
<p>Low Battery Warning</p>	<ul style="list-style-type: none"> • Last remaining bar on the right in battery icon flashes. 	<ul style="list-style-type: none"> • None
<p>Dead Battery Alarm</p>	<ul style="list-style-type: none"> • Gas reading replaced by FAIL. • Battery icon flashes. 	<ul style="list-style-type: none"> • Double pulsing tone (two pulses in quick succession) occurs once a second.
<p>Sensor Failure</p>	<ul style="list-style-type: none"> • Gas reading replaced by FAIL. 	<ul style="list-style-type: none"> • Double pulsing tone (two pulses in quick succession) once a second.
<p>System Failure</p>	<ul style="list-style-type: none"> • Gas reading replaced by FAIL. • SYS displays below FAIL. 	<ul style="list-style-type: none"> • Double pulsing tone (two pulses in quick succession) once a second.

Resetting Gas Alarms

To reset a gas alarm, press the POWER/MODE button after the gas reading falls below the low alarm point. If a TWA or STEL alarm has been activated, it cannot be reset unless you turn off the unit.

NOTE: Even though the gas concentration may have returned to normal or may have fallen below the low alarm point, the alarm indications will continue until you have reset the alarm using the POWER/MODE button.

Responding to Alarms

This section describes response to gas, over range, battery, sensor failure, and system failure alarms.

Responding to Gas Alarms

1. Follow your established procedure for an increasing gas condition or a decreasing oxygen condition.
2. Reset the alarm by pressing and releasing the POWER/MODE button after the alarm condition has been cleared.

Responding to an Over Range Alarm

WARNING: An over range condition may indicate an extreme toxic gas or oxygen concentration. Confirm the gas concentration with a different 01 Series or with another gas detecting device.

1. Follow your established procedure for an increasing gas condition.
2. Reset the alarm by pressing and releasing the POWER/MODE button after the alarm condition has cleared.
3. Calibrate the 01 Series as described in the calibration section of this manual.
4. If the over range condition continues, you may need to replace the sensor.
5. If the over range condition continues after you have replaced the sensor, contact RKI Instruments, Inc. for further instructions.

Responding to Battery Alarms

WARNING: The 01 Series is not operational as a gas monitoring device during a dead battery alarm. Take the 01 Series to a non-hazardous area and change the alkaline batteries as described in "Replacing the Batteries".

The 01 Series is fully functional in a low battery warning condition. However, only a couple of days of operation may remain depending on certain conditions such as alarm occurrences and how often the backlight comes on.

NOTE: Alarms and the back light feature consume battery power and reduce the amount of operating time remaining.

When a low battery warning occurs, change the batteries as soon as

possible. Refer to the instructions in “Replacing the Batteries” for more information.

Responding to a Sensor Failure Alarm

1. Try calibrating the 01 Series first, as described in “Calibration”, before replacing the sensor.
2. If the sensor failure continues, replace the sensor as described in “Replacing the Sensor”.
3. If the gas sensor failure condition continues after you have replaced the gas sensor, contact RKI Instruments, Inc. for further instructions.

Responding to a System Failure Alarm

1. If a system failure occurs, try turning the unit off then on again.
2. If the unit remains in system failure, contact RKI Instruments, Inc. for further instructions.

Alarm Points

The 01 Series allows you to display and set the alarm points. The alarm point factory settings are summarized below:

Table 4: Alarm Points of the 01 Series

Model	Low Alarm	High Alarm	STEL	TWA
CO-01	25 ppm	50 ppm	200 ppm	25 ppm
HS-01	10.0 ppm	30.0 ppm	15.0 ppm	10.0 ppm
OX-01	19.5% Decreasing	23.5% Increasing	N/A	N/A

In the table above, Low Alarm and High Alarm for the CO-01 and HS-01 refer to a rising concentration of the target gases. The Low Alarm is triggered at the Low Alarm concentration listed in the table. For the CO-01 that would be 25 ppm CO, and for the HS-01 that would be 10.0 ppm. The High Alarm is triggered when the High Alarm concentration is reached.

For the OX-01, Low Alarm is triggered when the concentration of oxygen falls below 19.5%. When the concentration of oxygen rises above 23.5%, High Alarm is activated.

Displaying and Adjusting the Alarm Points

1. Make sure the 01 Series is turned off. The LCD should be blank.
2. Press and hold the AIR button, then press and hold the POWER/MODE button.

- As soon as segments appear on the display (approximately one second), release the AIR button. When the unit “beeps,” release the POWER/MODE button to put the 01 Series into Alarm Point Adjustment Mode. The LCD should display the low alarm setting and the battery level.

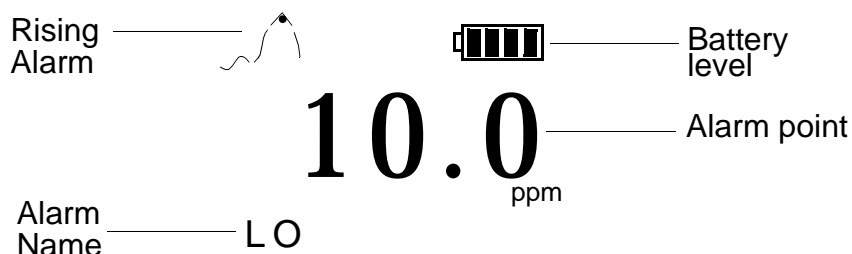

Figure 4: LCD in Alarm Adjustment Mode, CO-01 & HS-01

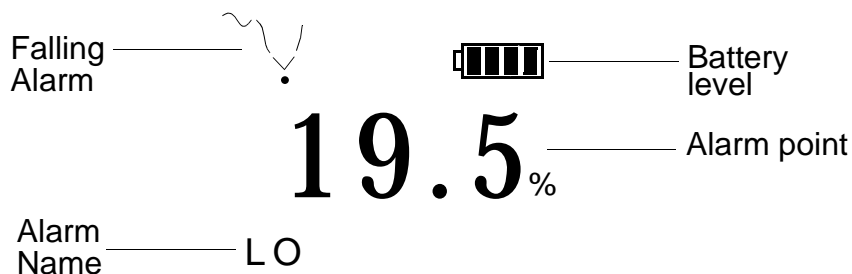

Figure 5: LCD in Alarm Adjustment Mode, OX-01

NOTE: If the LCD should show “CAL” in the lower left corner, the 01 Series is in Calibration Mode. You will need to press and hold the POWER/MODE button to turn off the unit. Begin again with step 2 above.

- While the 01 Series is displaying the low alarm point, use the AIR button to change the setting. Pressing and releasing the AIR button in quick succession increases the low alarm point one number at a time. Pressing and holding the AIR button increases the low alarm point by ten percentage points at a time.

NOTE: If you pass the desired alarm point setting, continue increasing the alarm point until it reaches the maximum setting, at which point the alarm point number will “wrap around” to its minimum setting.

- Press and release the POWER/MODE button to display the high alarm point in the LCD. If you have changed the low alarm point setting, it will be saved automatically after you press the POWER/MODE button.

NOTE: If you press and hold the POWER/MODE button for too long (about five seconds), you will turn off the unit.

6. Use the AIR button to change the high alarm point setting. Pressing and releasing the AIR button in quick succession increases the high alarm point one number at a time. Pressing and holding the AIR button increases the high alarm point at a faster rate.

NOTE: You can only cycle through the alarm points once before the 01 Series goes into its start-up sequence, which then places the unit in Measuring Mode. If you want to cycle through the alarm points again, press and hold the POWER/MODE button to turn off the 01 Series. Then begin with step 2 above to put the unit back into Alarm Point Adjustment Mode.

7. When you are finished viewing or adjusting the alarm point settings, press and release the POWER/MODE button until the ROM number of the unit appears on the LCD. (The ROM is the component that contains the software that runs the 01 Series.) The 01 Series will then go into its start-up sequence followed by Measuring Mode.

Calibration

This section covers the calibration of the 01 Series. Setting the fresh air reading is described first followed by setting the span (CO-01 and HS-01) or zero (OX-01) reading. You are also told what is needed to complete the task and how to assemble the calibration kit.

WARNING: Use a 0.5 LPM (liters per minute) fixed flow regulator when calibrating. Using a different flow rate may adversely affect the accuracy of the calibration.

Calibration Frequency

The optimum frequency of calibration depends heavily on how the 01 Series is used. For example, instruments used daily may need to be calibrated weekly or monthly, while instruments that are used only a few times a year may need to be calibrated before each use. Typical calibration frequencies range from monthly to quarterly. Make sure to develop a calibration schedule tailored to your application.

Setting the Fresh Air Reading

You will need to set the fresh air reading first before setting the span (zero for OX-01) reading.

1. Find a fresh air environment of normal oxygen content (20.9%) that is free of toxic or combustible gases.
2. With the unit on and in Measuring Mode, press and hold the AIR button. The LCD displays “hold” prompting you to hold the AIR button.
3. Release the AIR button when the LCD displays “AdJ”. The unit will set the reading and return to Measuring Mode. On the CO-01 and HS-01, the unit will set the reading to 0 ppm and on the OX-01 it will set the reading to 20.9% oxygen

Setting the Span (Zero for OX-01) Reading

This section tells you how to set the span reading on the CO-01 and HS-01 and the zero reading on the OX-01 using Calibration Mode.

Preparation

Set the fresh air reading as described in “Setting the Fresh Air Reading.” You will also need the supplies listed below. A calibration kit is available from RKI Instruments, Inc. for each 01 Series model (see “Parts List”).

- A gas cylinder with an appropriate concentration of the target gas for the CO-01 or HS-01, or a cylinder of 100% nitrogen for the OX-01.

NOTE: On the OX-01, instead of 100% nitrogen (0% oxygen), it is allowable to use higher than 0% oxygen to set the zero level. RKI Instruments, Inc. recommends 18% oxygen or lower.

- To carry out the calibration, you will need a fixed-flow regulator with a flow rate of 0.5 LPM (liters per minute), non-absorbent tubing, and the calibration adapter that will fit over the 01 Series' sensor.

Assembling the Calibration Kit

WARNING: *Calibrate the 01 Series in a non-hazardous environment.*

1. Attach the calibration adapter to the top of the 01 Series. The calibration adapter opens up like a clothes pin. It fits over the 01 Series's gas sensor port on top of the sensor retainer and secures itself there by clamping to the front and back of the 01 Series.
2. Attach the calibration tubing to the calibration adapter, and then attach the opposite end of the tubing to the regulator.

NOTE: Do not attach the regulator to the gas cylinder at this time.

Setting the Span Reading (Zero Reading for OX-1)

1. Make sure you have set the fresh air reading and have set up the calibration kit as described in the procedures above.
2. Make sure the 01 Series is off.
3. Press and hold the AIR button, and then press and hold the POWER/MODE button. Release both buttons when you hear a "beep". The unit is in Calibration Mode and the LCD displays "CAL" in the lower left and the battery level in the upper right. It also displays the gas concentration that the unit expects you to use, the calibration value, when setting the span.
4. If necessary, use the AIR button to adjust the calibration value to the desired setting. The calibration value *must* match the gas concentration in the calibration cylinder.
5. Press the POWER/MODE button to accept the calibration value. The current gas reading is displayed, and "CAL" will blink in the lower left corner of the LCD. The unit is now in Span Adjustment Mode.

If you want to cancel the calibration while in Span Adjustment Mode, press and hold the AIR key for 3 seconds and the unit will not make any span adjustments and begin its startup sequence.

NOTE: If one of the control buttons is not pressed within 10 minutes, the unit will return to Measuring Mode automatically.

6. Attach the regulator to the gas cylinder. The fixed-flow regulator automatically begins introducing the calibration sample to the sensor.
7. Let the gas flow for two minutes. After two minutes, press the POWER/MODE button. The unit will adjust the span (CO-01 and HS-01) or zero (OX-01) based on the calibration value that was saved in step 5 above. As soon as the unit makes the calibration adjustment, it will begin its start-up sequence, and then it will enter Measuring Mode.

NOTE: If the 01 Series displays “FAIL” on the LCD after you press the Power/MODE button, the sensor output may be too low or too high or there may be a problem with the calibration gas or calibration kit setup. Refer to the Troubleshooting section in Maintenance to solve the problem.

8. Remove the regulator from the gas cylinder and the calibration adapter from the unit.

NOTE: If the gas reading is high enough (low enough for the OX-01) when the unit enters Measuring Mode, an alarm condition will occur. If this occurs, reset the alarm using the POWER/MODE button when the gas reading falls below (rises above for the OX-01) the alarm point.

Maintenance

This section describes troubleshooting procedures for the 01 Series. It also describes how to change the 01 Series's batteries as well as how to replace the sensor and sensor cover.

WARNING: *RKI Instruments, Inc. recommends that service, calibration, and repair of RKI instruments be performed by personnel properly trained for this work. Replacing sensors and other parts with original equipment does not affect the intrinsic safety of the instrument.*

Troubleshooting

The troubleshooting table describes error messages, symptoms, probable causes, and recommended actions for problems you may encounter with the 01 Series.

Table 5: Troubleshooting the 01 Series

Symptoms	Probable Causes	Recommended Action
<ul style="list-style-type: none">The LCD is blank.	<ul style="list-style-type: none">The unit may have been turned off.The alkaline batteries may need to be replaced.	<ol style="list-style-type: none">To turn on the unit, press and hold the POWER/MODE button.If the unit does not turn on, replace the alkaline batteries.If the difficulties continue, contact RKI Instruments, Inc. for further instruction.
<ul style="list-style-type: none">The LCD shows abnormally high readings but other gas detection instruments do not.	<ul style="list-style-type: none">The unit may need to be recalibrated.The sensor may need replacement.	<ol style="list-style-type: none">Recalibrate the unit.Replace the sensor and calibrate the unit.If the difficulties continue, contact RKI Instruments for further instruction.

Table 5: Troubleshooting the 01 Series

Symptoms	Probable Causes	Recommended Action
<ul style="list-style-type: none"> • “FAIL” displays during span adjustment. 	<ul style="list-style-type: none"> • The calibration value may not match the cylinder gas concentration. • The sample gas is not reaching the sensor because of a bad connection. • The calibration cylinder may be out of gas or is outdated. • The sensor may need replacement. 	<ol style="list-style-type: none"> 1. Check all calibration tubing for leaks or for any bad connections. 2. Make sure the 01 Series has been properly set up for calibration. 3. Verify that the calibration cylinder contains an adequate supply of fresh test sample. 4. If the fail condition continues, replace the sensor. 5. If the difficulties continue, contact RKI Instruments, Inc. for further instruction.
<ul style="list-style-type: none"> • “FAIL SYS” is displays on the LCD 	<ul style="list-style-type: none"> • A microprocessor failure has occurred. 	<ol style="list-style-type: none"> 1. Turn off the unit and turn it on again. 2. If difficulties continue, contact RKI Instruments, Inc.

Replacing the Batteries

WARNING: *To prevent ignition of a hazardous atmosphere, batteries must only be changed in an area known to be nonhazardous.*

Replace the batteries when the battery icon indicates that the unit is in low battery warning. When in low battery warning, only one battery level indication bar is displayed in the battery icon on the LCD, and this icon will be flashing.



To Replace the Batteries

1. Verify that the 01 Series is off.
2. Remove the battery end protective rubber boot.

3. Rotate the captive battery cover screw counterclockwise to remove battery compartment door.

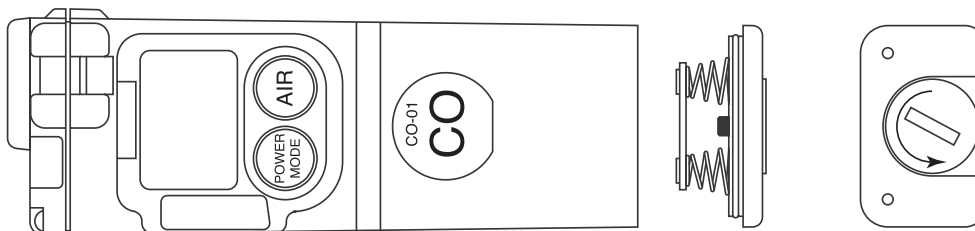

Figure 6: Removing the Battery Compartment Door

4. Carefully remove the old alkaline batteries.
5. Carefully install the new AAA alkaline batteries. Follow the battery diagram inside the battery compartment.
6. Reinstall the battery cover.

NOTE: If the unit has been without batteries or if the old batteries have been dead for an extended period, allow 10 minutes after the new batteries have been installed for the sensor to stabilize.

Replacing the Sensor

WARNING: *Replace the sensor in a non-hazardous environment.*

1. Verify that the 01 Series is off.
2. Remove the sensor end protective rubber boot.
3. With a small Phillips screwdriver, carefully unscrew the two screws that hold the sensor retainer in place.

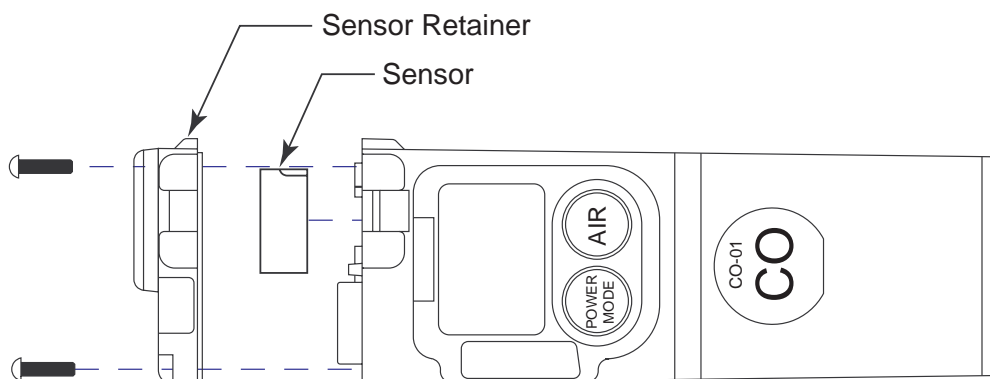
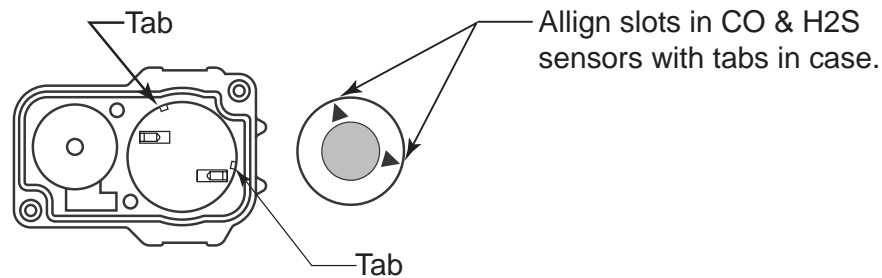

Figure 7: Removing the Sensor Retainer

4. Carefully remove the old sensor from the sensor socket.
5. Carefully insert the replacement sensor in the socket. Make sure the sensor face with the colored ring is facing up.



Note: Oxygen sensor is not keyed.
Unit shown without Sensor Retainer

Figure 8: Replacing the Sensor

CAUTION: When replacing the sensor, verify that the sensor is properly aligned with its socket before inserting it into the socket. The CO and H₂S sensors have alignment slots which match up with alignment tabs in the sockets. Forcing a sensor into its socket may damage the sensor or the socket.

6. Reinstall the sensor retainer.
7. Allow 10 minutes for the new sensor to stabilize.
8. Calibrate the new sensor as described in the calibration section of this manual.

Replacing the Sensor Cover and Charcoal Filter

WARNING: Replace the sensor cover and charcoal filter in a non-hazardous environment.

When replacing the sensor filters, it is recommended that you replace all filters at the same time. The HS-01 and OX-01 only have the sensor cover. The CO-01 has the sensor cover and the charcoal filter.

1. Verify that the 01 Series is off.
2. With a small Phillips screwdriver, carefully unscrew the single screw that holds the membrane retainer in place.

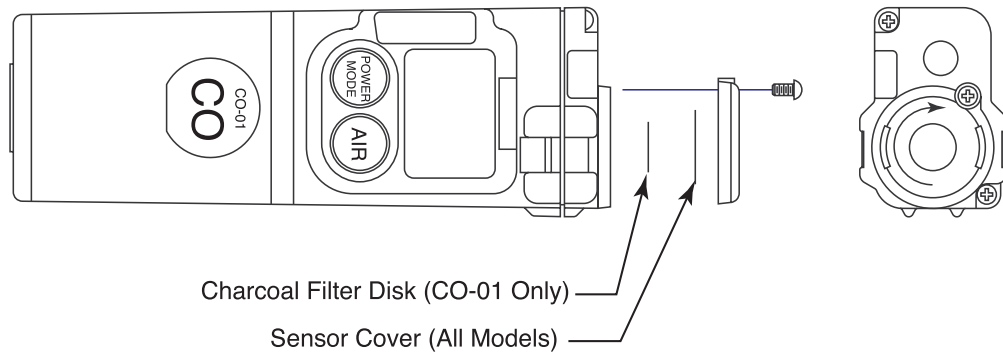

Figure 9: Replacing the Sensor Filters

3. Rotate the membrane retainer about one-quarter turn counterclockwise to remove it from the sensor retainer (the top of the unit).
4. Carefully remove the sensor cover from the recess in the sensor retainer. If you have a CO-01, also remove the charcoal filter.
5. If you have a CO-01, install a charcoal filter into the smaller recess and make sure they are properly seated in the recess. Then insert one sensor cover in the larger recess (all models).

CAUTION: *Be very careful not to push the charcoal filter disk too far into the recess in the sensor retainer. Lay the disk carefully in the opening on top of the small tabs in the recess.*

6. Reinstall the membrane retainer.

Parts List

Table 6 lists replacement parts and accessories for the 01 Series.

Table 6: Parts List

Part Number	Description
06-1248RK	Calibration kit tubing (specify length in feet)
07-6009RK	Gasket for battery cover
10-1099RK	Screw, M2X 4mm pan head Phillips, stainless steel, for membrane retainer
10-1105RK	Screw, M2X 8mm pan head Phillips, stainless steel, for sensor retainer
10-1141RK	Screw, M2.5 x 3mm pan head Phillips, stainless steel, for alligator and belt clip installation.
13-0112RK	Wrist strap
13-0114RK	Alligator clip
13-0213RK	Belt Clip
13-1115RK	Captive battery cover screw
20-0316RK	Rubber boot, sensor end
20-0317RK	Rubber boot, battery end
21-1848RK	Membrane retainer
21-1849RK	Sensor retainer
33-0166RK	Sensor cover disk membrane, 10 pack
33-7106RK	Filter disk, charcoal, 10 pack
49-1110RK	AAA size alkaline battery
81-0064RK-01	Calibration cylinder, 50 ppm CO in air, 34 liter steel
81-0078RK-01	Calibration cylinder, 100% nitrogen, 34 liter, steel
81-0151RK-04	Calibration cylinder, 25 ppm H ₂ S in nitrogen, 34 liter, aluminum
81-1003RK	Regulator, fixed flow, 0.5 LPM, for 17/34 liter steel cylinder

Table 6: Parts List

Part Number	Description
81-1004RK	Regulator, fixed flow, 0.5 LPM, for 58/34 liter aluminum cylinder, 103 liter steel cylinder
81-1104RK	Calibration adapter for 01 Series & GasWatch 2
81-CO01-LV	Calibration kit for CO-01, one 34 liter steel gas cylinder (50 ppm CO in air), regulator, calibration cup, case, tubing
81-HS01-LV	Calibration kit for HS-01, one 34 liter aluminum gas cylinder (25 ppm H ₂ S in nitrogen), regulator, calibration cup, case, & tubing
81-OX01-LV	Calibration kit for OX-01, one 34 liter steel gas cylinder (100% nitrogen), regulator, calibration cup, case, tubing
ES-1821	Carbon monoxide sensor
ES-1821L	Carbon monoxide sensor, for low humidity use
ES-1827	Hydrogen sulfide sensor
ES-1827L	Hydrogen sulfide sensor, for low humidity use
OS-BM2	Oxygen sensor