



INSTRUMENTS

**65-2484RK
Multi Point Detector
Operator's Manual**

Part Number: 71-0252RK

Revision: A

Released: 11/26/14

WARNING

Read and understand this instruction manual before operating detector. Improper use of the detector could result in bodily harm or death.

Periodic calibration and maintenance of the detector is essential for proper operation and correct readings. Please calibrate and maintain this detector regularly! Frequency of calibration depends upon the type of use you have and the sensor types. Typical calibration frequencies for most applications are between 3 and 6 months, but can be required more often or less often based on your usage.

Product Warranty

RKI Instruments, Inc. warrants gas alarm equipment sold by us to be free from defects in materials, workmanship, and performance for a period of one year from date of shipment from RKI Instruments, Inc. Any parts found defective within that period will be repaired or replaced, at our option, free of charge. This warranty does not apply to those items which by their nature are subject to deterioration or consumption in normal service, and which must be cleaned, repaired, or replaced on a routine basis. Examples of such items are:

- a) Absorbent cartridges
- b) Pump diaphragms and valves
- c) Fuses
- d) Batteries
- e) Filter elements

Warranty is voided by abuse including mechanical damage, alteration, rough handling, or repair procedures not in accordance with the operator's manual. This warranty indicates the full extent of our liability, and we are not responsible for removal or replacement costs, local repair costs, transportation costs, or contingent expenses incurred without our prior approval.

THIS WARRANTY IS EXPRESSLY IN LIEU OF ANY AND ALL OTHER WARRANTIES AND REPRESENTATIONS, EXPRESSED OR IMPLIED, AND ALL OTHER OBLIGATIONS OR LIABILITIES ON THE PART OF RKI INSTRUMENTS, INC. INCLUDING BUT NOT LIMITED TO, THE WARRANTY OF MERCHANTABILITY OR FITNESS FOR A PARTICULAR PURPOSE. IN NO EVENT SHALL RKI INSTRUMENTS, INC. BE LIABLE FOR INDIRECT, INCIDENTAL, OR CONSEQUENTIAL LOSS OR DAMAGE OF ANY KIND CONNECTED WITH THE USE OF ITS PRODUCTS OR FAILURE OF ITS PRODUCTS TO FUNCTION OR OPERATE PROPERLY.

This warranty covers instruments and parts sold to users by authorized distributors, dealers, and representatives as appointed by RKI Instruments, Inc.

We do not assume indemnification for any accident or damage caused by the operation of this gas monitor, and our warranty is limited to the replacement of parts or our complete goods.

Table of Contents

Overview	1
Specifications	1
Description	4
Detectors	4
Conduit Seal	9
Junction Box	10
Installation	10
Mounting the Multi-Point Detector	10
Wiring the Multi-Point Detector to a Controller	13
Startup	20
Introducing Incoming Power	20
Setting the Zero (Fresh Air) Reading	20
Maintenance	21
Preventive Maintenance	21
Troubleshooting	23
Replacing Components of the Multi-Point Detector	24
Calibration, LEL, CO, and H₂S Detectors	30
Preparing for Calibration	30
Setting the Zero Reading	31
Setting the Response Reading	31
Returning to Normal Operation	31
Calibration, Oxygen Detector	32
Preparing for Calibration	32
Setting the Fresh Air Reading	32
Setting the Zero Reading	33
Returning to Normal Operation	33
Calibration, ESM-01 Detector	33
Preparing for Calibration	34
Setting the Zero Reading	34
Setting the Response Reading	35
Returning to Normal Operation	35
Parts List	36

Overview

This manual describes the 65-2484RK multi point direct connect detector. This manual also describes how to install, start up, maintain, and calibrate the detector when it is used with a gas monitoring controller. A parts list at the end of this manual lists replacement parts and accessories for the detector.

Specifications

WARNING: Do not use this product in a manner not specified in this instruction manual.

Table 1 lists specifications for the multi-point detector.

Table 1: Specifications

Target Gas	<p>65-2484RK-01: LEL/O₂/H₂S/AsH₃, methane calibration standard for LEL 65-2484RK-02: LEL/O₂/H₂S/Cl₂, methane calibration standard for LEL 65-2484RK-03: LEL/O₂/H₂S/HCN, methane calibration standard for LEL 65-2484RK-04: LEL/O₂/H₂S/NH₃, methane calibration standard for LEL 65-2484RK-05: LEL/O₂/H₂S/PH₃, methane calibration standard for LEL 65-2484RK-06: LEL/O₂/H₂S/SO₂, methane calibration standard for LEL</p> <p>65-2484RK-11: LEL (IR CH₄)/O₂/H₂S/AsH₃, methane calibration for LEL 65-2484RK-12: LEL (IR CH₄)/O₂/H₂S/Cl₂, methane calibration for LEL 65-2484RK-13: LEL (IR CH₄)/O₂/H₂S/HCN, methane calibration for LEL 65-2484RK-14: LEL (IR CH₄)/O₂/H₂S/NH₃, methane calibration for LEL 65-2484RK-15: LEL (IR CH₄)/O₂/H₂S/PH₃, methane calibration for LEL 65-2484RK-16: LEL (IR CH₄)/O₂/H₂S/SO₂, methane calibration for LEL</p> <p>65-2484RK-21: LEL/H₂S/CO/AsH₃, methane calibration standard for LEL 65-2484RK-22: LEL/H₂S/CO/Cl₂, methane calibration standard for LEL 65-2484RK-23: LEL/H₂S/CO/HCN, methane calibration standard for LEL 65-2484RK-24: LEL/H₂S/CO/NH₃, methane calibration standard for LEL 65-2484RK-25: LEL/H₂S/CO/PH₃, methane calibration standard for LEL 65-2484RK-26: LEL/H₂S/CO/SO₂, methane calibration standard for LEL</p> <p>65-2484RK-31: LEL (IR CH₄)/H₂S/CO/AsH₃, methane calibration for LEL 65-2484RK-32: LEL (IR CH₄)/H₂S/CO/Cl₂, methane calibration for LEL 65-2484RK-33: LEL (IR CH₄)/H₂S/CO/HCN, methane calibration for LEL 65-2484RK-34: LEL (IR CH₄)/H₂S/CO/NH₃, methane calibration for LEL 65-2484RK-35: LEL (IR CH₄)/H₂S/CO/PH₃, methane calibration for LEL 65-2484RK-36: LEL (IR CH₄)/H₂S/CO/SO₂, methane calibration for LEL</p> <p>65-2484RK-41: LEL/O₂/CO/AsH₃, methane calibration standard for LEL 65-2484RK-42: LEL/O₂/CO/Cl₂, methane calibration standard for LEL 65-2484RK-43: LEL/O₂/CO/HCN, methane calibration standard for LEL 65-2484RK-44: LEL/O₂/CO/NH₃, methane calibration standard for LEL 65-2484RK-45: LEL/O₂/CO/PH₃, methane calibration standard for LEL 65-2484RK-46: LEL/O₂/CO/SO₂, methane calibration standard for LEL</p> <p>65-2484RK-51: LEL (IR CH₄)/O₂/CO/AsH₃, methane calibration for LEL 65-2484RK-52: LEL (IR CH₄)/O₂/CO/Cl₂, methane calibration for LEL 65-2484RK-53: LEL (IR CH₄)/O₂/CO/HCN, methane calibration for LEL 65-2484RK-54: LEL (IR CH₄)/O₂/CO/NH₃, methane calibration for LEL 65-2484RK-55: LEL (IR CH₄)/O₂/CO/PH₃, methane calibration for LEL 65-2484RK-56: LEL (IR CH₄)/O₂/CO/SO₂, methane calibration for LEL</p> <p>*Note: Since the 65-2484RK is a direct connect detector, the calibration is done at the controller.</p>
------------	--

Table 1: Specifications

Sampling Method	Diffusion
Detection Range	LEL: 0 to 100 %LEL (lower explosive limit) O ₂ : 0 to 25 %volume CO: 0 to 300 ppm (parts per million) H ₂ S: 0 to 100 ppm (parts per million) AsH ₃ : 0 - 1.50 ppm Cl ₂ : 0 - 3.00 ppm HCN: 0 - 15.0 ppm NH ₃ : 0 - 75.0 ppm PH ₃ : 0 - 1.00 ppm SO ₂ : 0 - 6.00 ppm
Response Time	90% in 30 seconds
Accuracy	<u>Catalytic Combustible Gas:</u> ± 5% of reading or ± 2% LEL (whichever is greater) <u>IR Combustible Gas:</u> ± 5% of reading or ± 2% of full scale (whichever is greater) <u>Oxygen:</u> ± 0.5% O ₂ <u>Carbon Monoxide:</u> ± 5% of reading or ± 5 ppm CO (whichever is greater) <u>Hydrogen Sulfide:</u> ± 5% of reading or ± 2 ppm H ₂ S (whichever is greater) <u>ESM-01:</u> ± 10% of reading or ± 5% of full scale (whichever is greater)
Operating Temperature	23°F to 104°F (-5°C to 40°C)

NOTE: The following symbol on the detector label is a caution to the user to refer to this documentation for installation and operation instructions: 

WARNING: *When using the 65-2484RK, you must follow the instructions and warnings in this manual to assure proper and safe operation of the 65-2484RK and to minimize the risk of personal injury. Be sure to maintain and periodically calibrate the 65-2484RK as described in this manual.*

Description

This section describes the multi-point detector. It consists of the detectors, the terminal strips, the conduit seal, and the junction boxes.

Detectors

This section describes the components of the various detectors that are used with each model of the 65-2484RK.

61-0140RK LEL Detector

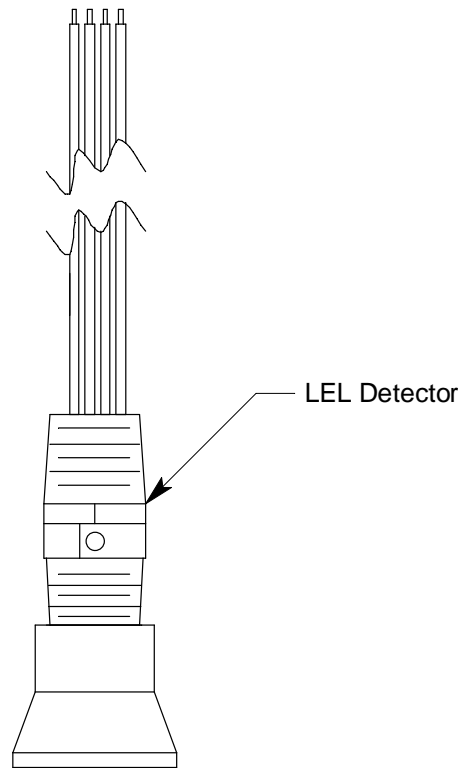

Figure 1: 61-0140RK LEL Detector Component Location

The combustible gas detector is a catalytic type detector that produces an electrical output that corresponds to the detection range. It is packaged in a 1/2 inch NPT nipple with a sintered metal flame arrestor on one end allowing ambient air to diffuse into the detector. The flame arrestor also contains any sparks which may occur within the detector. The 1/2 inch NPT mounting threads at the top of the detector allow you to install it in the bottom conduit hub of the junction box with the use of a 3/4 in. x 1/2 in. NPT reducer. A rainshield screws onto the bottom of the detector (flame arrestor end). The rainshield helps protect the detector from rain and debris in the monitoring environment. Four color-coded leads extend from the top of the detector. The leads allow you to connect the detector to the terminal block.

61-0190RK IR LEL Detector

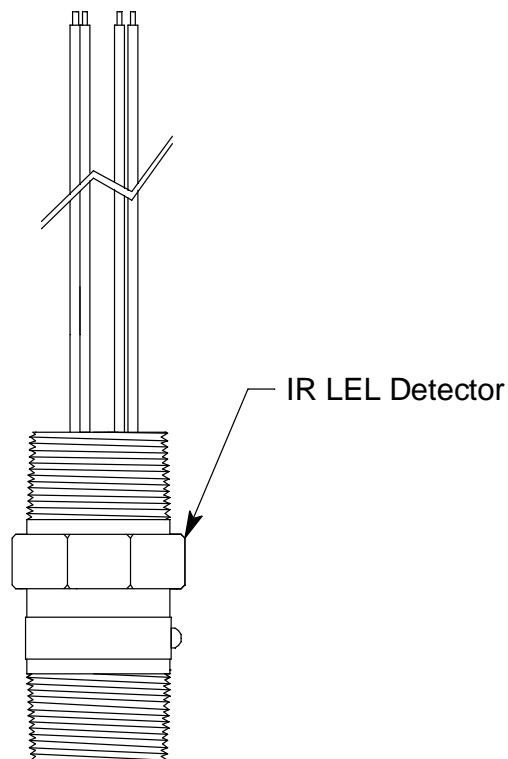

Figure 2: 61-0190RK IR LEL Detector Component Location

The infrared LEL detector is made up of a miniature infrared combustible gas LEL detector housed and encapsulated in a pipe nipple. The pipe nipple has 3/4" NPT threads on each end and a 1 1/4" hex that allows removal or installation of the detector with a wrench. A porous flame arrestor that is coated with a hydrophobic film that repels liquids is on one end of the detector and allows sample gas to enter the detector. The flame arrestor also contains any sparks which may occur within the detector. Four color coded leads, red, white, green, and black, extend from the other end of the detector. The leads allow you to connect the detector to the terminal block. To distinguish the propane detector from the methane detector (in case the replacement sensor label that is applied to one of the leads is lost), a short length of red shrink tubing is applied to the white wire of the propane detector near where the wire comes out of the nipple.

Oxygen Detector

The detector consists of the oxygen sensor, the detector housing body, detector housing cap, and cap gasket.

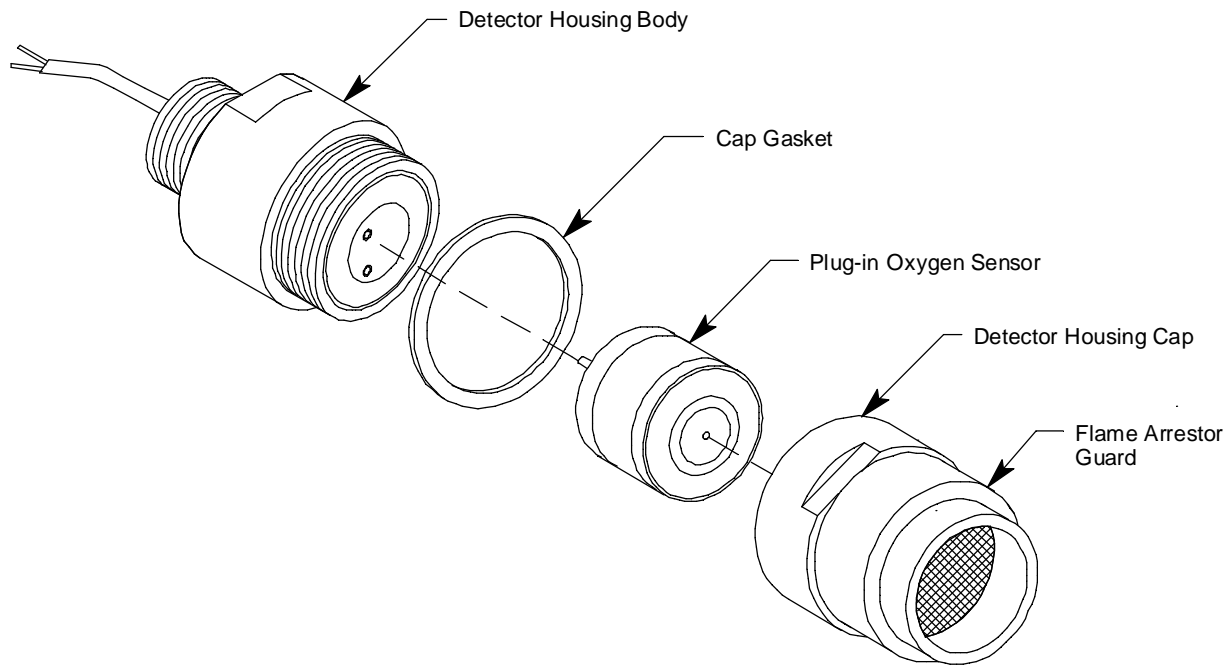

Figure 3: Oxygen Detector Component Location

Detector Housing Body

The detector housing body protects the electronic components within the housing. Use the mounting threads at the top of the housing to screw the oxygen detector into the 3/4" NPT hub on the bottom of the junction box. Two wires extend from the top of the detector housing body. Use these wires to connect the oxygen detector to the terminal block. One of the wires is white and one of the wires is green.

The housing includes two sockets installed on a circuit board. These sockets accept the plug-in sensor's two pins to provide electrical connection for the sensor. The circuit board with the sockets conditions the sensor's signal before the signal reaches the controller.

Housing Cap & Cap Gasket

The housing cap screws onto the detector housing. It retains the plug-in sensor and protects it from damage. A foam gasket is installed inside the housing cap that seals against the sensor face. The housing cap also includes a flame arrester which contains any sparks that may occur within the detector and a flame arrester guard which protects the flame arrester from damage. Unscrew the detector cap to access the plug-in sensor for maintenance or replacement. A cap gasket seals the interface between the housing and cap.

Plug-in Oxygen Sensor

The plug-in sensor is secured in the detector assembly by the housing cap. It has two pins that mate with the sockets in the detector housing body. Through a series of chemical and electrical reactions, the sensor produces an electrical output that corresponds to the detection range of the transmitter.

H₂S Detector

The detector consists of the detector housing body, detector housing cap, cap gasket, rubber boot, spacer, and H₂S sensor.

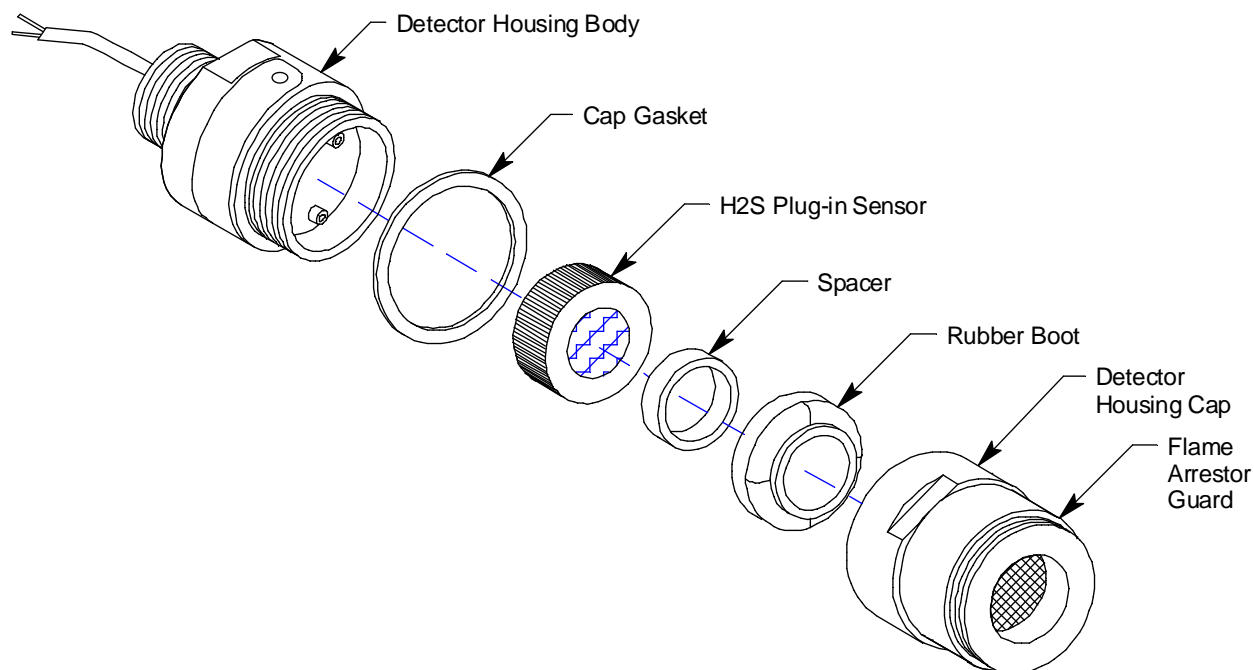

Figure 5: H₂S Detector Component Location

Detector Housing, Housing Cap, & Cap Gasket

The detector housing protects the sensing components within the housing. Use the mounting threads at the top of the housing to screw the H₂S detector into a 3/4" NPT hub. Use the removable cap near the bottom of the housing to access the sensor for maintenance or replacement. The cap protects the sensor from damage and includes a flame arrester which contains any sparks which may occur within the detector housing. A cap gasket seals the interface between the housing and cap. A flame arrester guard is permanently bonded to the cap.

Two wires extend from the top of the detector housing. Use these wires to connect the H₂S detector to the multi-point detector. The housing includes a four-socket pattern. This socket pattern accepts the sensor's four pins to secure the sensor within the detector housing. A pre-amplifier, located between the sockets and two interconnect wires, conditions the sensor's signal before the signal reaches the controller.

Rubber Boot and Spacer

A rubber boot and spacer are installed between the detector housing cap and the sensor. They help ensure that the detector remains plugged into the detector housing body.

Sensor

The sensor is secured within the sensor housing by the detector housing cap. It has four pins that mate with the sockets in the detector housing body. Through a series of chemical and electrical reactions, the sensor produces an electrical output that is proportional to the detection range of the detector.

CO Detector

The detector consists of the CO sensor, charcoal filter with rubber boot, detector housing body, detector housing cap, and cap gasket.

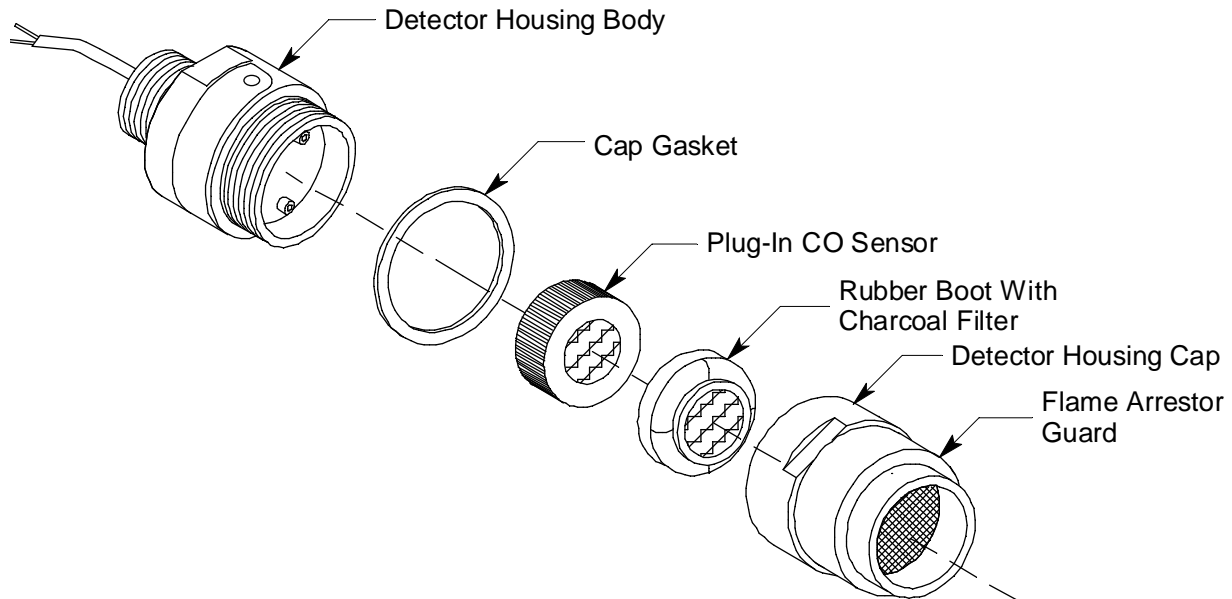

Figure 4: CO Detector Component Location

Detector Housing, Housing Cap, & Cap Gasket

The detector housing body protects the sensing components within the housing. Use the 3/4" NPT mounting threads at the top of the housing to screw the CO detector into the bottom conduit hub of the junction box. Use the removable cap near the bottom of the housing to access the sensor for maintenance or replacement. The cap protects the sensor from damage and includes a flame arrestor which contains any sparks which may occur within the detector housing. A cap gasket seals the interface between the housing and cap. A flame arrestor guard is permanently bonded to the cap.

Two wires extend from the top of the detector housing body. Use these wires to connect the CO detector to the multi-point detector. The housing includes a four-socket pattern. This socket pattern accepts the sensor's four pins to secure the sensor within the detector housing. A pre-amplifier, located between the sockets and two interconnect wires, conditions the sensor's signal before the signal reaches the controller.

Plug-In Sensor

The sensor is secured within the sensor housing by the housing cap. It has four pins that mate with the sockets in the detector housing body. Through a series of chemical and electrical reactions, the sensor produces an electrical output that corresponds to the detection range of the detector.

Charcoal Filter

The disc-shaped charcoal filter is secured to the face of the CO sensor with a rubber boot. The charcoal filter prevents interference gases (hydrogen sulfide [H₂S] and certain hydrocarbons) from producing false CO readings.

ESM-01 Detector

The ESM-01 detector consists of the detector housing body, detector housing cap, splashguard, cap gasket, and the plug-in sensor.

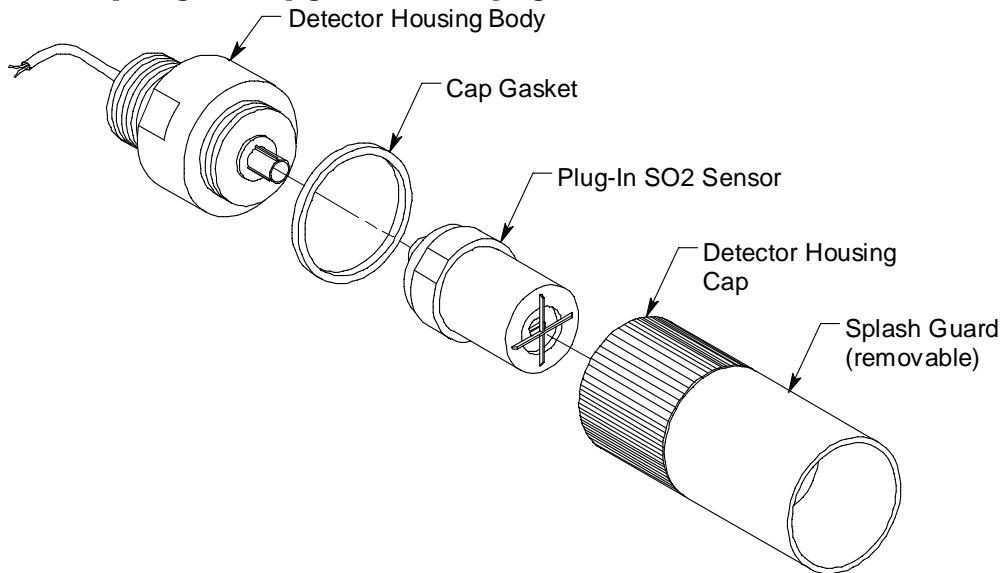

Figure 6: ESM-01 Toxic Detector Component Location

Detector Housing Body

The detector housing body protects the electronic components within the housing. Use the mounting threads at the top of the housing to screw the toxic detector into a 3/4" NPT hub. Two wires extend from the top of the detector housing body. Use these wires to connect the toxic detector to a controller. One of the wires is black and one of the wires is color coded depending on the detector type. See the appropriate figure for your detector head for the color code assignments (Figure 9 - Figure 14).

The housing body includes a 12 position connector at the bottom of the housing body. The plug-in sensor mates to this connector. A pre-amplifier located between the connector and the two interconnect wires conditions the sensor's signal before the signal reaches the controller.

Housing Cap, Cap Gasket, & Splashguard

The housing cap screws onto the detector housing. It retains the sensor and protects it from damage. A removable splashguard is screwed onto the detector cap to protect the sensor from impact damage, direct water spray, and splashing. Unscrew the detector cap to access the sensor for maintenance or replacement. A cap gasket seals the interface between the housing and cap.

Plug-in Sensor

The plug-in sensor is secured in the detector assembly by the housing cap. Through a series of chemical and electrical reactions, the sensor produces an electrical output that corresponds to the detection range of the sensor.

Conduit Seal

The conduit seal isolates the volumes of the 2 junction boxes.

Junction Boxes

Use the junction boxes to install the multi-point detector at a mounting site that is remote from the controller. The junction boxes protect the terminal strips and wiring connections made to the terminal strips. Use the top 3/4" conduit hub to connect wiring from the terminal strips to the controller. Use the cover on the front of the junction boxes to access the interior of the junction boxes. The detectors and terminal strips are factory installed in the junction boxes.

Installation

This section describes procedures to mount the multi-point detector in the monitoring environment and wire the detector to a controller.

Mounting the Multi-Point Detector

1. Select a mounting site that is representative of the monitoring environment. Consider the following when you select the mounting site.
 - Select a site where the detector is not likely to be bumped or disturbed. Make sure there is sufficient room to perform start-up, maintenance, and calibration procedures.
 - Select a site where the target gases are likely to be found first.

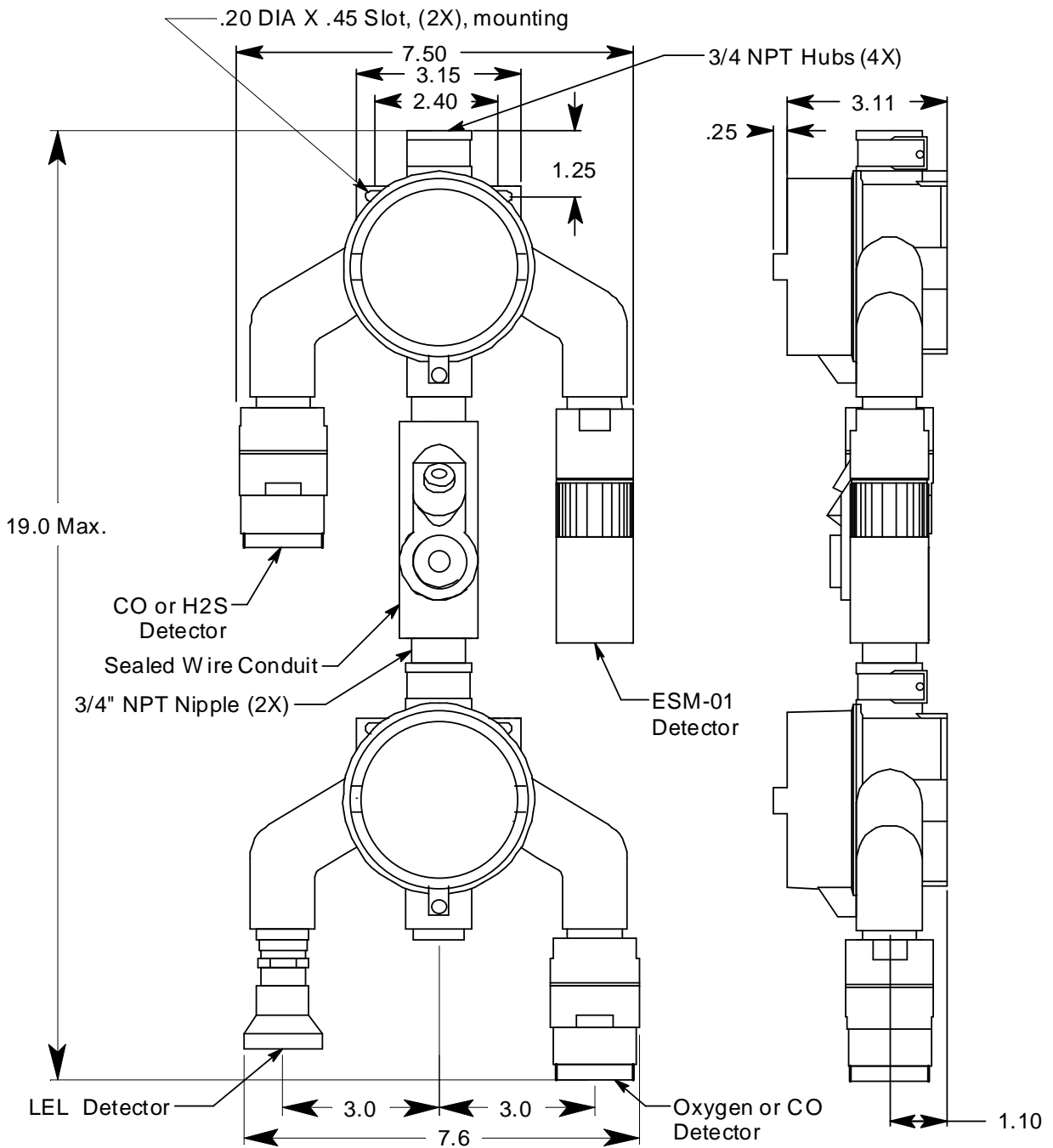

**Figure 7: Outline & Mounting Dimensions for Versions with Catalytic LEL Detector
 (65-2484RK-0X, 65-2484RK-2X, 65-2484RK-4X)**

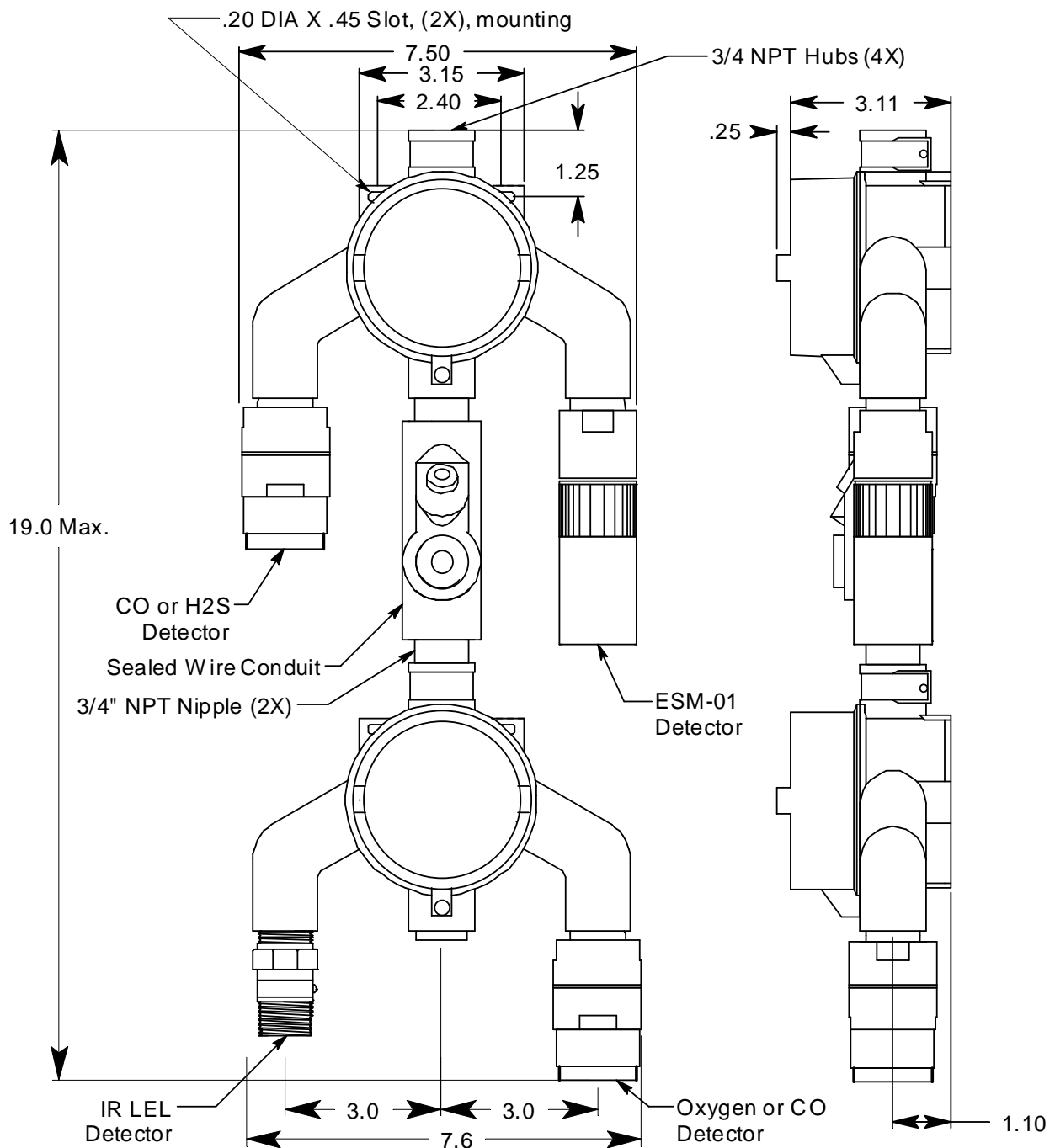

Figure 8: Outline & Mounting Dimensions for Versions with IR LEL Detector (65-2484RK-1X, 65-2484RK-3X, 65-2484RK-5X)

- At the mounting site you select, use #10 screws to mount the detector to a vertical surface.

CAUTION: Mount the multi-point detector with the detectors facing down (see Figures 7-8).

NOTE: If your application does not require a specific mounting site, mount the detector at approximately breathing level.

Wiring the Multi-Point Detector to a Controller

WARNING: *Always verify that the power source is OFF before you make wiring connections.*

1. Turn off the controller.
2. Turn off or unplug power to the controller.
3. Remove the junction box cover from the top junction box.
4. Guide a ten-conductor, shielded cable, or ten wires in conduit through the top conduit hub of the junction box. Use appropriate conduit fittings and construction technique for the environmental rating of the junction box. The junction box is rated NEMA 4X.
5. Connect the wires to the multi-point detector using the terminal blocks in the top junction box.

CAUTION: *If using shielded cable, leave the drain wire insulated and disconnected at the multi-point detector. You will connect the opposite end of the cable's drain wire at the controller.*

6. Secure the junction box cover to the junction box.
7. Route the cable or wires leading from the multi-point detector through one of the conduit hubs at the controller housing. Use appropriate conduit fittings and construction technique for the environmental rating of the controller. RKI controllers are typically rated NEMA 4X.

CAUTION: *Do not route power and multi-point detector wiring through the same conduit hub. The power cable may disrupt the transmission of the detector signal to the controller.*

8. Connect the wires to the applicable controller terminal strips. See the controller operator's manual and the controller's detector head specification sheet. Also see Figures 9-14 for wiring diagrams.

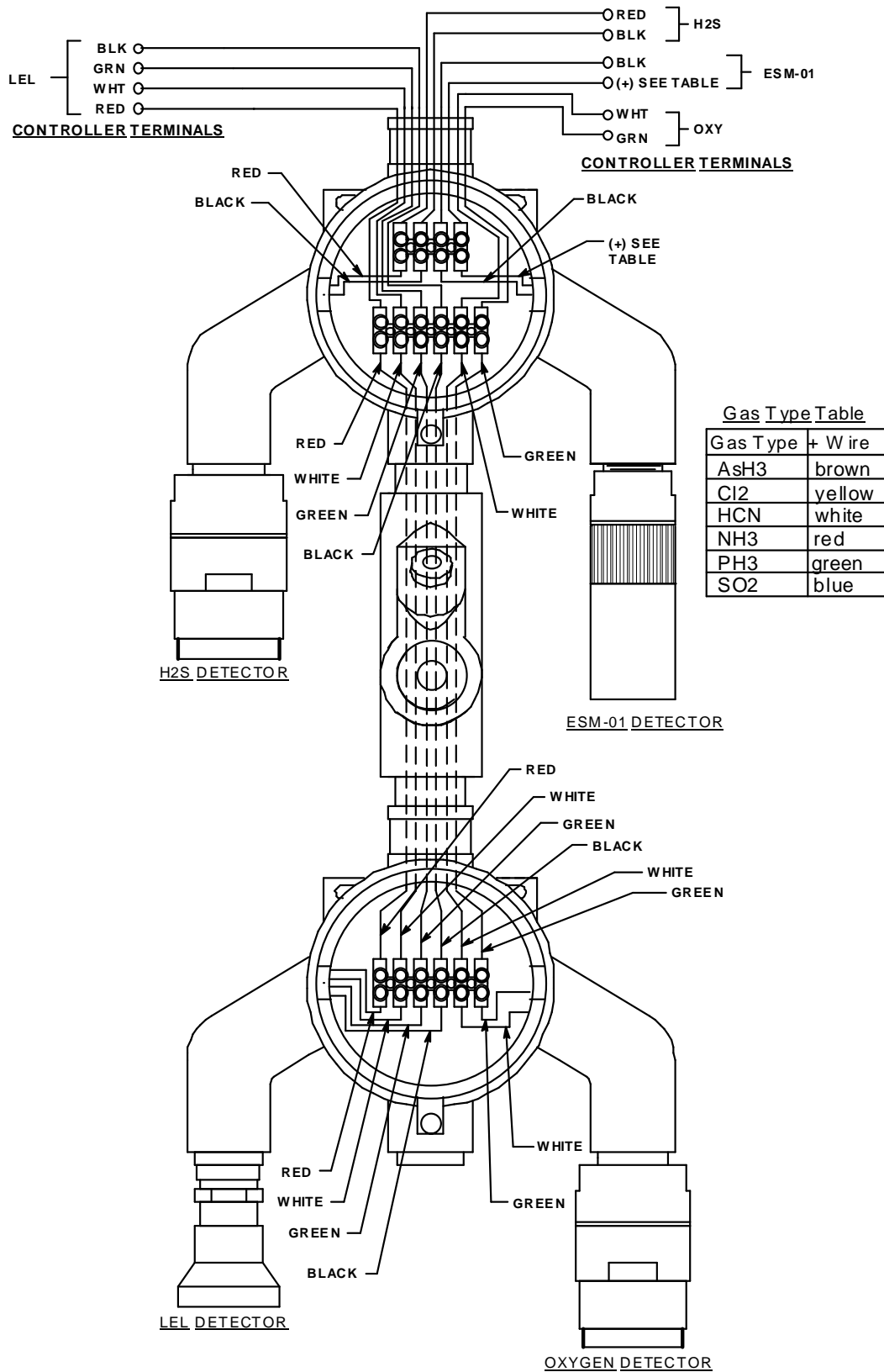

Figure 9: Wiring for Catalytic LEL/O₂/H₂S/ESM-01 Versions (65-2484RK-0X)

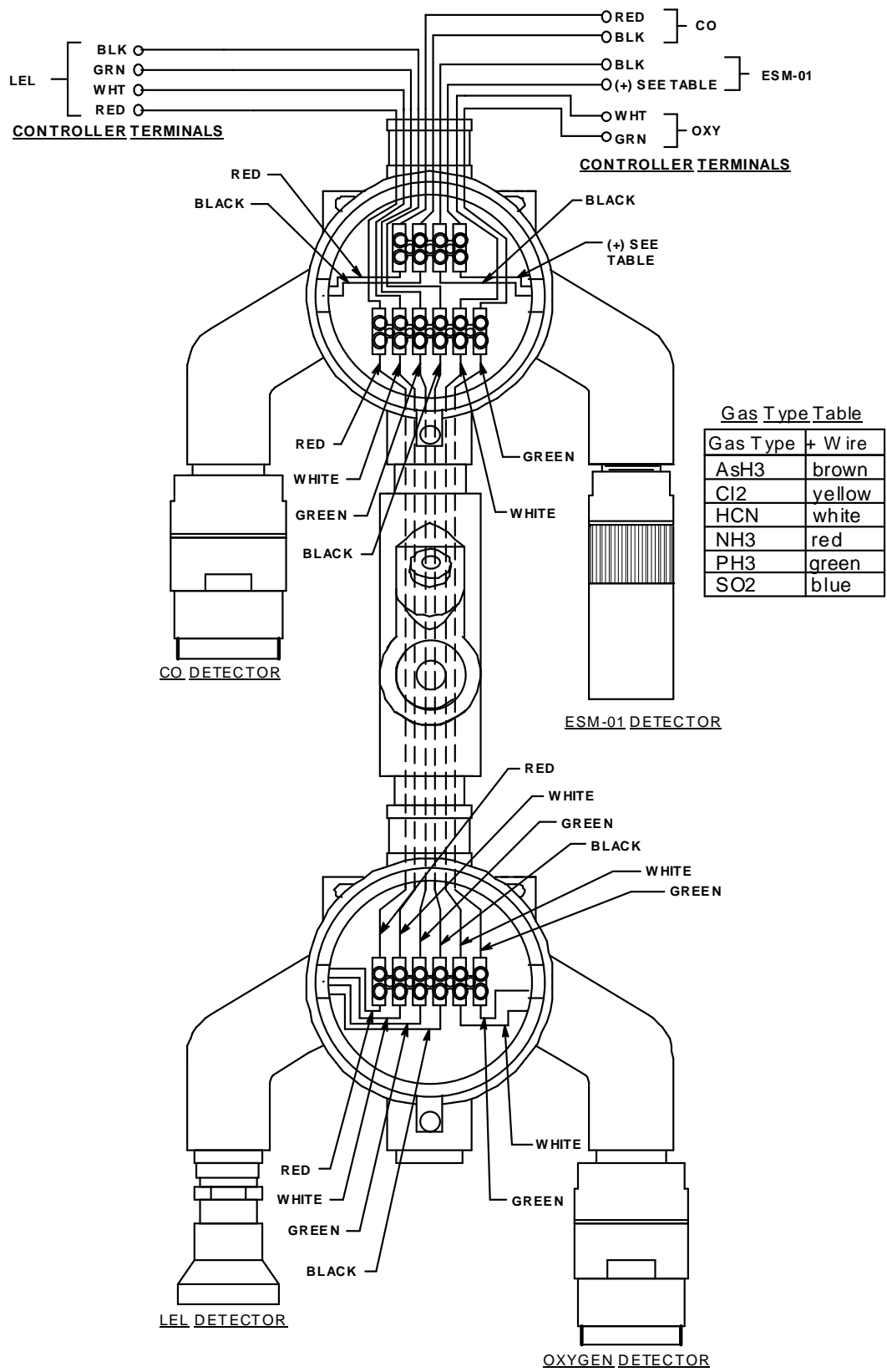

Figure 10: Wiring for Catalytic LEL/O₂/CO/ESM-01 Versions (65-2484RK-4X)

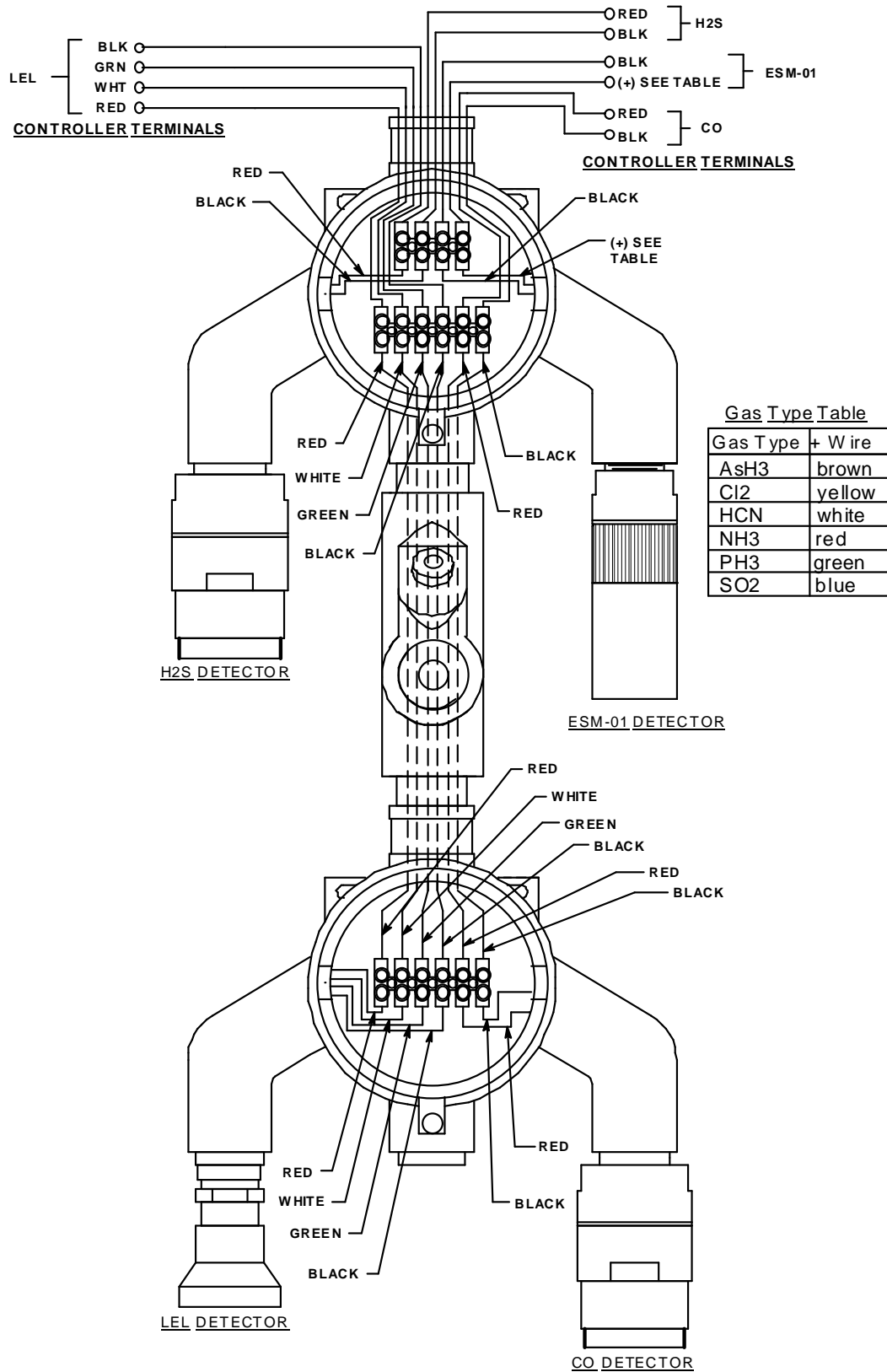
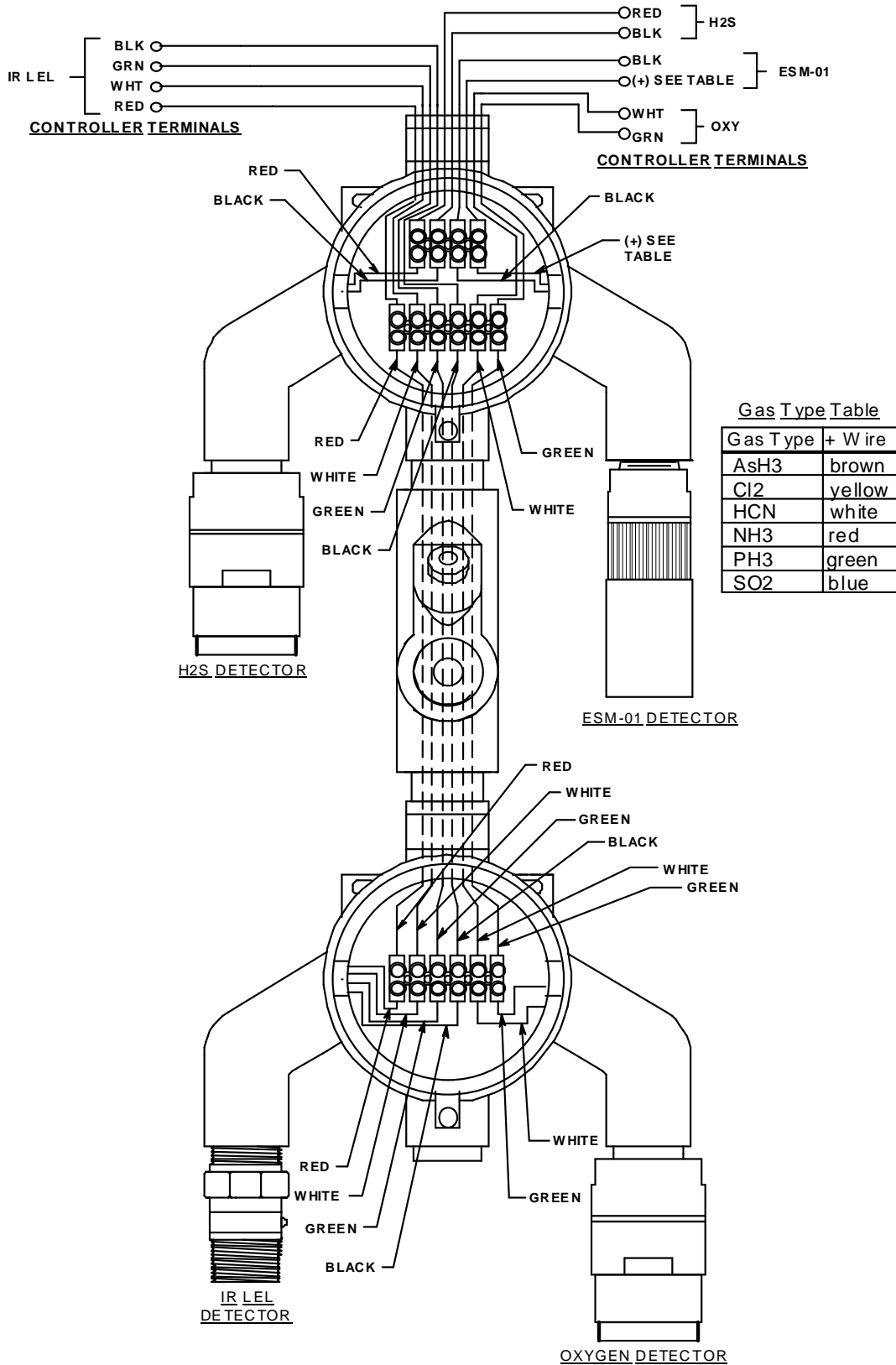
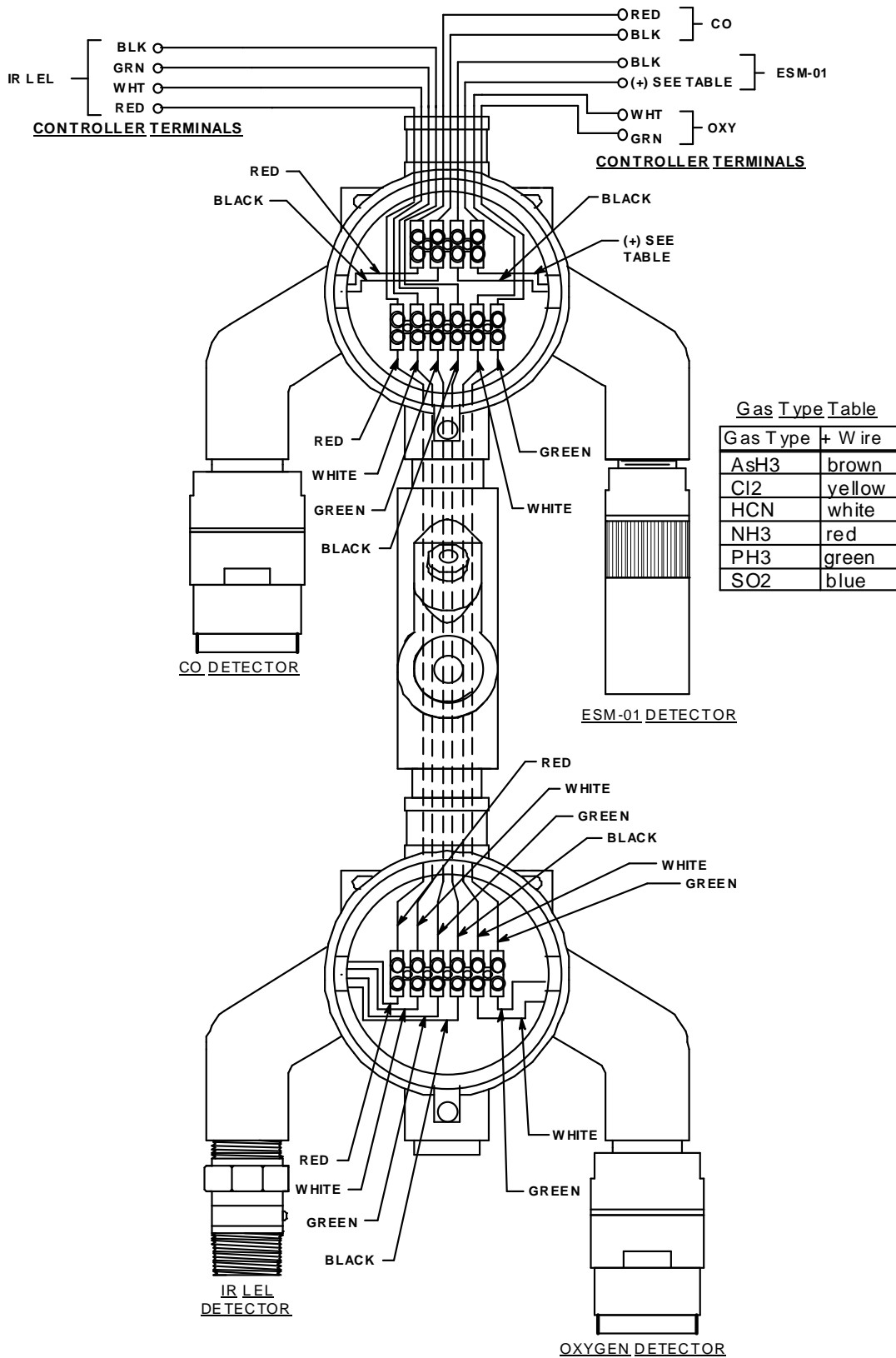

Figure 11: Wiring for LEL/CO/H₂S/ESM-01 Versions (65-2484RK-2X)



**Figure 12: Wiring for IR LEL/O₂/H₂S/ESM-01 Versions
(65-2484RK-1X)**



**Figure 13: Wiring for IR LEL/O₂/CO/ESM-01 Versions
(65-2484RK-5X)**

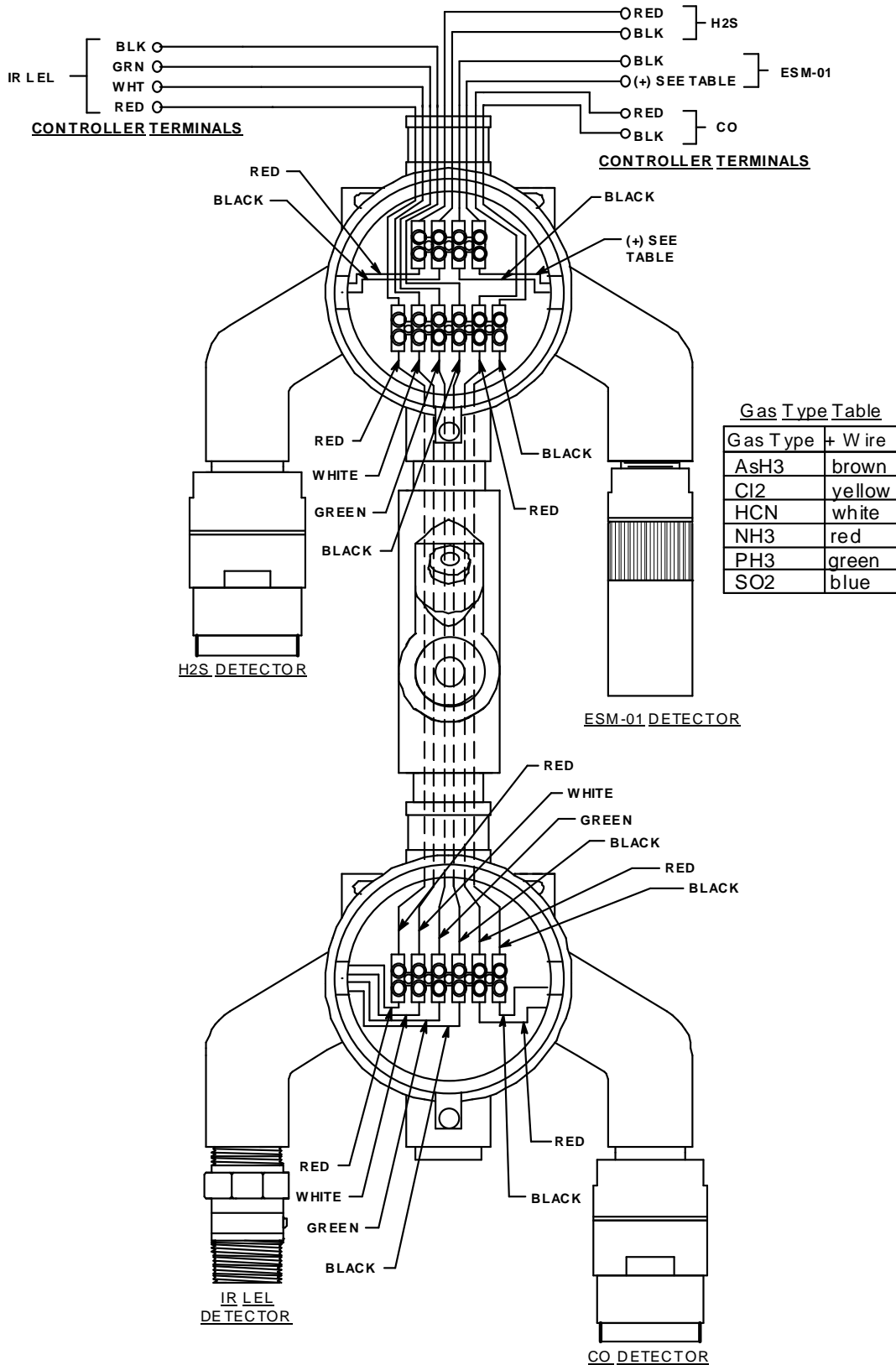

**Figure 14: Wiring for IR LEL/CO/H₂S/ESM-01 Versions
(65-2484RK-3X)**

9. Connect the cable's drain wire to an available chassis ground at the controller. RKI controllers typically have a ground stud that can be used to ground the cable's drain wire.

Start Up

This section describes procedures to start up the multi-point detector and place the detector into normal operation.

Introducing Incoming Power

1. Complete the installation procedures described earlier in this manual.
2. Verify that the power wiring to the controller is correct and secure. Refer to the controller operator's manual.
3. Turn on power to the controller.
4. Turn on the controller.
5. Verify that the controller is on and operating properly. Refer to the controller operator's manual.

CAUTION: *Allow the multi-point detector to warm up for 5 minutes before you continue with the next section, "Setting the Zero (Fresh Air) Reading".*

Setting the Zero (Fresh Air) Reading

CAUTION: *If you suspect the presence of a target gas in the monitoring environment, use the calibration kit and a zero air calibration cylinder to introduce "fresh air" to the desired detector and verify an accurate zero setting. See the Calibration section for instructions to introduce zero air to the desired detector.*

1. Verify that the detector is in a fresh air environment (environment known to be free of toxic and combustible gases, and of normal oxygen content, 20.9%).
2. At the controller, verify a reading of:
 - 0 %LEL for combustible gas
 - 20.9% for oxygen
 - 0 ppm for H₂S, CO, or toxic ESM-01 channel

If the display reading is the appropriate fresh air reading, start up is complete. The detector is in normal operation. If the display reading is not the appropriate fresh air reading, continue with step 3.

3. Perform a zeroing (fresh air adjustment) operation at the controller. See the controller operator's manual for directions.

Maintenance

This section describes maintenance procedures. It includes preventive maintenance, troubleshooting, and component replacement procedures.

Preventive Maintenance

This section describes a preventive maintenance schedule to ensure the optimum performance of the multi-point detector. It includes daily, monthly, and quarterly procedures.

Daily

At the controller, verify a display reading of:

- 0 %LEL for combustible gas
- 20.9% for oxygen
- 0 ppm for H₂S, CO, or toxic ESM-01 channel

Investigate significant changes in the display reading.

Monthly

This procedure describes a test to verify that each detector in the multi-point detector responds properly to its target gas. It describes a test using a fixed flow regulator with an on/off knob. RKI Instruments, Inc. recommends using a 0.5 LPM (liters per minute) fixed flow regulator for the LEL, O₂, H₂S, or CO channels. See Table 3 on page 33 to determine the correct calibration cup and regulator for the ESM-01 toxic channel.

WARNING: *The ESM-01 detector calibration cup is different than that of the LEL/O₂/H₂S/CO detectors. Ensure that you are using the correct calibration cup for the detector you are testing. See “Calibration, ESM-01 Toxic Detector” on page 33.*

NOTE: Performing a response test on the multi-point detector may cause alarms. Be sure to put the controller into its calibration program or disable external alarms before performing this test.

Preparing for the response test

1. Place the controller into its calibration program or disable external alarms.
2. Verify that the controller display reading for the channel you are testing is:
 - 0 %LEL for combustible gas
 - 20.9% for oxygen
 - 0 ppm for H₂S, CO, or toxic ESM-01 channel

If the display reading is not the appropriate fresh air reading, set the zero reading of the detector as described in the Start Up section of this manual, then continue this procedure.

3. Screw the calibration cup onto the bottom of the detector you are testing if you are testing an LEL, O₂, H₂S, or CO detector. If you are testing the ESM-01 detector, unscrew the splashguard before pushing on the calibration cup.
4. Screw the regulator into the calibration cylinder.

NOTE: Ensure that you are using an appropriate calibration cylinder for the channel you are testing.

5. Use the calibration kit sample tubing to connect the regulator to the calibration cup. If you are testing the ESM-01 toxic detector, check the bottom of the calibration cup to see if it has a specified flow direction through the cup and if it does, make sure you connect the tube from the regulator to the inlet port. The 81-1138RK calibration cup, which is used for all detectors except for Cl₂ and NH₃ detectors, has a specified flow direction on the bottom of the cup. The 81-1138RK-CL2 and 81-1138RK-NH3 calibration cups do not have a specified flow direction.

Performing the response test

1. Turn the regulator's on/off knob counterclockwise to open the regulator. Gas will begin to flow.
2. Allow the gas to flow for one minute for the LEL detector or two minutes for the O₂, H₂S, CO, and ESM-01 detectors, then verify that the reading is within $\pm 20\%$ of the cylinder gas concentration.

NOTE: If the reading is not within $\pm 20\%$ of the correct response reading, calibrate the detector as described in the Calibration section of this manual.

3. Turn the regulator's on/off knob clockwise to close the regulator.
4. Unscrew the regulator from the calibration cylinder.
5. For any additional detectors that you want to test, move the calibration cup to the detector, screw the regulator into the appropriate gas cylinder and repeat steps 1-4.
6. Unscrew the calibration cup from the detector if you are testing an LEL, O₂, H₂S, or CO detector. If you are testing the ESM-01 detector, screw the splashguard back onto the detector.
7. When the controller display reading falls below the alarm setpoints, return the controller to normal operation.
8. Store the components of the calibration kit in a safe place.

Quarterly

Calibrate the multi-point detector as described in the Calibration section of this manual.

Troubleshooting

The troubleshooting guide describes symptoms, probable causes, and recommended action for problems you may encounter with the multi-point detector.

NOTE: This troubleshooting guide describes multi-point detector problems only. See the controller operator's manual for problems you may encounter with the controller.

Table 2: Troubleshooting the Multi-Point Detector

Condition	Symptom(s)	Probable Causes	Recommended Action
Fail Condition	Controller indicates a fail condition.	<ul style="list-style-type: none"> The detector wiring is disconnected or misconnected. The O₂, H₂S, CO, or ESM-01 plug-in sensor is not properly plugged into the sockets in the detector housing body. The detector's zero reading is low enough to cause a fail condition. The detector is malfunctioning. 	<ol style="list-style-type: none"> Verify that the detector wiring is correct and secure. Confirm that the O₂, H₂S, CO, or ESM-01 plug-in sensor is installed properly. Perform a zero adjustment. A full calibration is recommended. If the fail condition continues, replace the O₂, H₂S, CO, or ESM-01 plug-in sensor as described later in this section. If the fail condition continues, contact RKI for further instruction.
Slow or No Response/ Difficult or Unable to Calibrate	<ul style="list-style-type: none"> Detector responds slowly or does not respond to response test. Unable to accurately set the zero or response reading during calibration. Detector requires frequent calibration. <p>Note: Under "normal" circumstances, the transmitter requires calibration once every 3 months. Some applications may require a more frequent calibration schedule.</p>	<ul style="list-style-type: none"> The calibration cylinder is low, out-dated, or defective. The flame arrestor on the LEL detector or in the O₂, H₂S, or CO detector housing cap is wet or clogged with dirt or other particulates. The calibration gas is not an appropriate concentration. The detector is malfunctioning. 	<ol style="list-style-type: none"> Verify that the calibration cylinder contains an adequate supply of a fresh test sample. Check the LEL detector or detector housing cap to determine if the flame arrestor is wet or dirty. Check the sensor face of the ESM-01 plug-in sensor to determine if it is wet or dirty. Clean if necessary. Verify that the calibration gas concentration is appropriate for each detector. If the calibration/response difficulties continue, replace the LEL detector or the O₂, H₂S, CO, or ESM-01 plug-in sensor as described later in this section. If the calibration/response difficulties continue, contact RKI for further instruction.

Replacing Components of the Multi-Point Detector

This section includes maintenance procedures for the LEL detector, the oxygen detector, the CO detector, the H₂S detector, and the ESM-01 detector.

Replacing the LEL Detector

1. Turn off the controller.
2. Turn off or unplug incoming power to the controller.
3. Remove the junction box cover from the bottom junction box.
4. Disconnect the detector leads from the terminal block in the junction box. Note the position of the color-coded leads as you remove them.
5. Unscrew the detector from the junction box hub.
6. Guide the detector leads of the replacement detector through the junction box hub then screw the mounting threads of the detector into the hub. If necessary for environmental conditions, apply thread sealant or teflon tape to the hub and/or detector threads to seal them.
7. Connect the detector leads to the terminal block the same way the old detector was wired. See the controller operator's manual and the controller's detector head specification sheet for the multi-point detector to verify the connections are correct. Also see Figures 9-14 for wiring diagrams.
8. Reinstall the junction box cover.
9. Turn on or plug in power to the controller.
10. Turn on the controller.

CAUTION: *Allow the replacement detector to warm up for 5 minutes before you continue with the next step.*

11. Calibrate the replacement detector as described in "Calibration, LEL, H₂S, and CO Detectors" on page 30.

Oxygen Detector

This section contains instructions to replace the plug-in oxygen sensor and to replace the entire detector assembly. In most cases it is not necessary to replace the entire detector assembly.

Replacing the Plug-In Oxygen Sensor

CAUTION: *The plug-in sensor contains electrolyte that is an irritant. Do not disassemble the sensor when replacing it with a new one. If electrolyte comes in contact with your skin, wash affected area thoroughly with soap and water.*

1. Turn off the controller.
2. Turn off or unplug power to the controller.
3. Unscrew the detector housing cap from the detector housing body. Make sure not to lose the cap gasket.
4. Unplug and remove the oxygen sensor.
5. Carefully plug the replacement sensor into the socket pattern that is located in the detector housing.
6. Make sure the cap gasket is in place and screw the detector housing cap back onto the

detector housing body.

7. Turn on or plug in power to the controller.
8. Turn on the controller and place into normal operation.

CAUTION: *Allow the replacement sensor to warm up for 5 minutes before you continue with the next step.*

9. Calibrate the detector as described in “Calibration, O₂ Detector” on page 32.

Replacing the Oxygen Detector

NOTE: In most cases, it is only necessary to replace the oxygen sensor.

1. Turn off the controller.
2. Turn off or unplug incoming power to the controller.
3. Remove the junction box cover from the bottom junction box.
4. Disconnect the detector leads from the terminal block in the junction box. Note the position of the color-coded leads as you remove them.
5. Unscrew the detector from the junction box hub.
6. Guide the detector leads of the replacement detector through the junction box hub then screw the mounting threads of the detector into the hub. If necessary for environmental conditions, apply thread sealant or teflon tape to the hub and/or detector threads to seal them.
7. Connect the detector leads to the terminal block the same way the old detector was wired. See the controller operator’s manual and the controller’s detector head specification sheet for the multi-point detector to verify the connections are correct. Also see Figures 9-14 for wiring diagrams.
8. Reinstall the junction box cover.
9. Turn on or plug in power to the controller.
10. Turn on the controller.

CAUTION: *Allow the replacement detector to warm up for 5 minutes before you continue with the next step.*

11. Calibrate the replacement detector as described in “Calibration, O₂ Detector” on page 32.

H₂S Detector

This section includes a procedure to replace the H₂S sensor and one to replace the entire detector assembly. In most cases it is not necessary to replace the entire detector assembly.

Replacing the Plug-In H₂S Sensor

CAUTION: *The sensor contains electrolyte which is a dilute acid. Do not disassemble the sensor when replacing it with a new one. If sensor electrolyte comes in contact with your skin, wash affected area thoroughly with soap and water.*

1. Turn off the controller.
2. Turn off or unplug power to the controller.

3. Unscrew the detector housing cap from the detector housing body. Make sure not to lose the cap gasket.
4. Unplug and remove the H₂S sensor with the rubber boot and spacer attached.
5. Remove the rubber boot and spacer from the old sensor.
6. Install the spacer and rubber boot onto the replacement sensor's face.
7. Carefully plug the replacement sensor into the socket pattern that is located in the detector housing.
8. Make sure the cap gasket is in place and screw the detector housing cap onto the detector housing body.
9. Turn on or plug in power to the controller.
10. Turn on the controller.

CAUTION: *Allow the replacement sensor to warm up for 5 minutes before you continue with the next step.*

11. Calibrate the detector as described in "Calibration, LEL, H₂S, and CO Detectors" on page 30.

Replacing the H₂S Detector

NOTE: In most cases, it is only necessary to replace the H₂S sensor.

1. Turn off the controller.
2. Turn off or unplug power to the controller.
3. Remove the junction box cover from the top junction box.
4. Disconnect the detector leads from the terminal block in the junction box. Note the position of the color-coded leads as you remove them.
5. Unscrew the detector from the junction box hub.
6. Guide the detector leads of the replacement detector through the junction box hub then screw the mounting threads of the detector into the hub. If necessary for environmental conditions, apply thread sealant or teflon tape to the hub and/or detector threads to seal them.
7. Connect the detector leads to the terminal block the same way the old detector was wired. See the controller operator's manual and the controller's detector head specification sheet for the multi-point detector to verify the connections are correct. Also see Figures 9-14 for wiring diagrams.
8. Reinstall the junction box cover.
9. Turn on or plug in power to the controller.
10. Turn on the controller.

CAUTION: *Allow the replacement detector to warm up for 5 minutes before you continue with the next step.*

11. Calibrate the replacement detector as described in "Calibration, LEL, H₂S, and CO Detectors" on page 30.

CO Detector

This section includes a procedure to replace the plug-in sensor, one to replace the charcoal filter, and one to replace the entire detector assembly. In most cases it is not necessary to replace the entire detector assembly.

Replacing the Plug-In CO Sensor

CAUTION: *The sensor contains electrolyte which is a dilute acid. Do not disassemble the sensor when replacing it with a new one. If sensor electrolyte comes in contact with your skin, wash affected area thoroughly with soap and water.*

1. Turn off the controller.
2. Turn off or unplug power to the controller.
3. Unscrew the detector housing cap from the detector housing body. Make sure not to lose the cap gasket.
4. Unplug and remove the CO sensor with the boot and charcoal filter attached.
5. Remove the rubber boot and charcoal filter from the old sensor.
6. Install the rubber boot with charcoal filter onto the replacement sensor's face.
7. Carefully plug the replacement sensor into the four-socket pattern that is located in the detector housing.
8. Make sure the cap gasket is in place and screw the detector housing cap back onto the detector housing body.
9. Turn on or plug in power to the controller.
10. Turn on the controller and place into normal operation.

CAUTION: *Allow the replacement sensor to warm up for 5 minutes before you continue with the next step.*

11. Calibrate the replacement sensor as described in "Calibration, LEL, H₂S, and CO Detectors" on page 30.

Replacing the Charcoal Filter

1. Turn off the controller.
2. Turn off or unplug power to the controller.
3. Unscrew the detector housing cap from the detector housing body.
4. Unplug and remove the CO sensor with the boot and charcoal filter attached.
5. Remove the rubber boot that secures the charcoal filter to the CO sensor.
6. Remove the charcoal filter from the rubber boot.
7. Place the replacement filter in the rubber boot in the same position as the filter you removed in the previous step.
8. Reinstall the rubber boot with charcoal filter to the CO sensor.
9. Carefully plug the replacement sensor into the four-socket pattern that is located in the detector housing.
10. Make sure the cap gasket is in place and screw the detector housing cap back onto the detector housing body.
11. Turn on or plug in power to the controller.
12. Turn on the controller and place into normal operation.

Replacing the CO Detector

NOTE: In most cases, it is only necessary to replace the CO sensor.

1. Turn off the controller.
2. Turn off or unplug power to the controller.
3. Remove the junction box cover from the top or bottom junction box, depending on where your CO detector is installed. Refer to Figures 9 - 14 for CO detector location.
4. Disconnect the detector leads from the terminal block in the junction box. Note the position of the color-coded leads as you remove them.
5. Unscrew the detector from the junction box hub.
6. Guide the detector leads of the replacement detector through the junction box hub then screw the mounting threads of the detector into the hub. If necessary for environmental conditions, apply thread sealant or teflon tape to the hub and/or detector threads to seal them.
7. Connect the detector leads to the terminal block the same way the old detector was wired. See the controller operator's manual and the controller's detector head specification sheet for the multi-point detector to verify the connections are correct. Also see Figures 9-14 for wiring diagrams.
8. Reinstall the junction box cover.
9. Turn on or plug in power to the controller.
10. Turn on the controller and place into normal operation.

CAUTION: *Allow the replacement detector to warm up for 5 minutes before you continue with the next step.*

11. Calibrate the replacement detector as described in the "Calibration, LEL, H₂S, and CO Detectors" on page 30.

ESM-01 Detector

This section includes a procedure to replace the ESM-01 sensor and one to replace the entire detector assembly. In most cases it is not necessary to replace the entire detector assembly.

Replacing the Plug-In ESM-01 Sensor

CAUTION: *The plug-in sensor contains electrolyte which is a dilute acid. Do not disassemble the sensor when replacing it with a new one. If sensor electrolyte comes in contact with your skin, wash affected area thoroughly with soap and water.*

1. Turn off the controller.
2. Turn off or unplug power to the controller.
3. Unscrew the detector housing cap with the splashguard from the detector housing body. Make sure not to lose the cap gasket.
4. Unplug and remove the toxic sensor.
5. Carefully plug the replacement sensor into the connector that is located in the detector housing body.

WARNING: *You must replace the plug-in sensor with the same type of sensor that is installed. A detector cannot be converted from one type of detector to another by using a different plug-in sensor. For example, if you are replacing an SO₂ sensor, you must replace it with an SO₂ sensor.*

6. Make sure the cap gasket is in place and screw the detector housing cap with the splashguard back onto the detector housing body.
7. Turn on power to the controller.
8. Turn on the controller.

CAUTION: *Allow the replacement sensor to warm up for 5 minutes before you continue with the next step.*

9. Calibrate the detector as described in “Calibration, ESM-01 Toxic Detector” on page 33.

Replacing the ESM-01 Detector

NOTE: In most cases, it is only necessary to replace the plug-in sensor.

1. Turn off the controller.
2. Turn off or unplug incoming power to the controller.
3. Remove the junction box cover from the top junction box.
4. Disconnect the detector leads from the terminal block in the junction box. Note the position of the color-coded leads as you remove them.
5. Unscrew the detector from the junction box conduit hub.
6. Guide the detector leads of the replacement detector through the controller conduit hub or junction box conduit hub, then screw the mounting threads of the detector into the hub. If necessary for environmental conditions, apply thread sealant or teflon tape to the hub and/or detector threads to seal them.
7. Connect the detector leads to the terminal block the same way the old detector was wired. See the controller operator’s manual and the controller’s detector head specification sheet for the multi-point detector to verify the connections are correct. Also see Figures 9-14 for wiring diagrams.
8. Reinstall the junction box cover.
9. Turn on or plug in power to the controller.
10. Turn on the controller.

CAUTION: *Allow the replacement detector to warm up for 5 minutes before you continue with the next step.*

11. Calibrate the replacement detector as described in “Calibration, ESM-01 Toxic Detector” on page 33.

Calibration Frequency

Although there is no particular calibration frequency that is correct for all applications, a calibration frequency of every 3 months is adequate for most multi-point detector applications. Unless experience in a particular application dictates otherwise, RKI Instruments, Inc. recommends a calibration frequency of every 3 months for the catalytic LEL, oxygen, H₂S, CO, and ESM-01 detectors and every 6 months for the infrared LEL detector.

If an application is not very demanding, for example detection in a clean, temperature controlled environment, and calibration adjustments are minimal at calibration, then a calibration frequency of every 6 months is adequate for the catalytic LEL, oxygen, H₂S, CO, and ESM-01 detectors and every 9 to 12 months is adequate for the infrared LEL detector.

If an application is very demanding, for example if the environment is not well controlled, then more frequent calibration than every 3 months for the catalytic LEL, oxygen, H₂S, CO, and ESM-01 detectors and every 6 months for the infrared LEL detector may be necessary.

Calibration, LEL, H₂S, and CO Detectors

This section describes how to calibrate the LEL, H₂S, and CO detectors on the multi-point detector. It includes procedures to prepare for calibration, set the zero reading, set the response reading, and return to normal operation. It describes calibration using a calibration kit that includes an 81-1117RK calibration cup, calibration gas, sample tubing, and a fixed flow regulator with an on/off knob. RKI Instruments, Inc. recommends using a 0.5 LPM (liters per minute) fixed flow regulator. To properly calibrate the multi-point detector, you must calibrate each connected detector. Perform the following procedure for each connected LEL, H₂S, or CO detector.

WARNING: *The controller is not an active gas monitoring device during the calibration procedure.*

Preparing for Calibration

WARNING: *Do not remove the junction box cover or detector housing cap while the circuits are energized unless the area is determined to be non-hazardous. Keep the junction box cover and detector housing cap tightly closed during operation.*

1. Screw the calibration cup onto the bottom of the detector you wish to calibrate.

NOTE: If you can verify that the multi-point detector is in a fresh air environment, you do not need to apply zero air to the detector before adjusting the zero reading.

2. Screw the regulator into the zero air calibration cylinder. Make sure the regulator is off. It is off when the on/off knob is turned all the way clockwise.
3. Use the calibration kit sample tubing to connect the fixed flow regulator to the calibration cup.
4. Put the controller into its calibration program. See the controller operator's manual

for instructions to enter the calibration program.

NOTE: RKI controllers have a minimum hold feature for zero adjustment and a peak hold feature for span adjustment. Because of this, the instructions call for turning off the gas to a detector before making adjustments.

Setting the Zero Reading

1. Follow the directions in the controller operator's manual for setting the zero reading.
2. When the instructions call for applying zero air to the detector, turn the regulator's on/off knob counterclockwise to open it. Gas will begin to flow.
3. Allow the gas to flow for two minutes.
4. Turn the regulator's on/off knob clockwise to close it.
5. Set the zero reading according to the controller operator's manual.
6. Unscrew the regulator from the zero air calibration cylinder. Leave the sample tubing connected to the regulator and the calibration cup.

Setting the Response Reading

1. Screw the regulator into the calibration gas cylinder. Make sure the regulator is off. It is off when the on/off knob is turned all the way clockwise.

NOTE: Ensure that you are using an appropriate calibration cylinder for the channel you are calibrating.

2. Follow the directions in the controller operator's manual for setting the response reading (span).
3. When the directions call for exposing the detector to gas, turn the regulator's on/off knob counterclockwise to open it. Gas will begin to flow.
4. Allow gas to flow for 1 minute for the LEL detector or 2 minutes for the H₂S and CO detectors before continuing with the directions.
5. Turn the regulator's on/off knob clockwise to close it.
6. Set the response reading according to the controller operator's manual.
7. Unscrew the regulator from the cylinder.

Returning to Normal Operation

1. Unscrew the calibration cup from the detector.

NOTE: For convenience, leave the regulator and calibration cup connected by the sample tubing.

2. When the controller display reading falls below the alarm points, return the controller to normal operation.

NOTE: If you do not allow the gas reading to decrease below the alarm points, then unwanted alarms may occur.

3. Verify that the controller display reading decreases and stabilizes at:
 - 0 %LEL for combustible gas

- 0 ppm for H₂S or CO
4. Store the components of the calibration kit in a safe and convenient place.

Calibration, O₂ Detector

This section describes how to calibrate the oxygen detector on the multi-point detector. It includes procedures to prepare for calibration, set the fresh air reading, set the zero reading, and return to normal operation. It describes calibration using a calibration kit that includes an 81-1117RK calibration cup, calibration gas, sample tubing, and a fixed flow regulator with an on/off knob. RKI Instruments, Inc. recommends using a 0.5 LPM (liters per minute) fixed flow regulator. To properly calibrate the multi-point detector, you must calibrate each connected detector. Perform the following procedure for the oxygen detector.

WARNING: *The controller is not an active gas monitoring device during the calibration procedure.*

Preparing for Calibration

WARNING: *Do not remove the junction box cover or detector housing cap while the circuits are energized unless the area is determined to be non-hazardous. Keep the junction box cover and detector housing cap tightly closed during operation.*

1. Screw the calibration cup onto the bottom of the oxygen detector.
2. Screw the regulator into the zero air calibration cylinder. Make sure the regulator is off. It is off when the on/off knob is turned all the way clockwise.

NOTE: If you can verify that the multi-point detector is in a fresh air environment, you do not need to apply zero air to the detector before adjusting the fresh air reading.

3. Use the calibration kit sample tubing to connect the fixed flow regulator to the calibration cup.
4. Put the controller into its calibration program. See the controller operator's manual for instructions to enter the calibration program.

NOTE: RKI controllers have a peak hold feature for fresh air adjustment and a minimum hold feature for zero adjustment. Because of this, the instructions call for turning off the gas to a detector before making adjustments.

Setting the Fresh Air Reading

1. Follow the directions in the controller operator's manual for setting the fresh air reading.
2. When the instructions call for applying zero air to the detector, turn the regulator's on/off knob counterclockwise to open it. Gas will begin to flow.
3. Allow the gas to flow for two minutes.
4. Turn the regulator's on/off knob clockwise to close it.
5. Set the fresh air reading according to the controller operator's manual.

- Unscrew the regulator from the zero air calibration cylinder. Leave the sample tubing connected to the regulator and the calibration cup.

Setting the Zero Reading

- Screw the regulator into the 100% nitrogen calibration gas cylinder. Make sure the regulator is off. It is off when the on/off knob is turned all the way clockwise.
- Follow the directions in the controller operator's manual for setting the zero reading.
- When the directions call for exposing the detector to gas, turn the regulator's on/off knob counterclockwise to open it. Gas will begin to flow.
- Allow gas to flow for 2 minutes before continuing with the directions.
- Turn the regulator's on/off knob clockwise to close it.
- Set the zero reading according to the controller operator's manual.
- Unscrew the regulator from the cylinder.

Returning to Normal Operation

- Unscrew the calibration cup from the oxygen detector.

NOTE: For convenience, leave the regulator and calibration cup connected by the sample tubing.

- When the controller display reading rises above the alarm points, return the controller to normal operation.

NOTE: If you do not allow the gas reading to rise above the alarm points, then unwanted alarms may occur.

- Verify that the controller display reading increases and stabilizes at 20.9% oxygen.
- Store the components of the calibration kit in a safe and convenient place.

Calibration, ESM-01 Toxic Detector

This section describes how to calibrate the ESM-01 type toxic detector. It includes procedures to prepare for calibration, set the fresh air reading, set the response reading, and return to normal operation. It describes calibration using a calibration kit that includes an 81-1138RK-XX calibration cup, calibration gas, sample tubing, and a fixed flow regulator with an on/off knob. The required sample flow rate and calibration cup depend on the detector being calibrated. Table 3 below lists the required calibration cups and regulators for the various toxic detectors.

Table 3: Required Calibration Cups and Flow Rates

Detector Type	Required Calibration Cup	Required Regulator/ Flowrate for Calibration Gas	Flow Direction Specified on Calibration Cup
Arsine (AsH ₃)	81-1138RK	81-1051RK, 0.5 LPM (liters per minute)	Yes
Chlorine (Cl ₂)	81-1138RK-CL2	81-1051RK, 0.5 LPM	No
Hydrogen Cyanide (HCN)	81-1138RK	81-1051RK, 0.5 LPM	Yes

Detector Type	Required Calibration Cup	Required Regulator/ Flowrate for Calibration Gas	Flow Direction Specified on Calibration Cup
Ammonia (NH ₃)	81-1138RK-NH3	81-1051RK-25, 0.25 LPM	No
Phosphine (PH ₃)	81-1138RK	81-1051RK, 0.5 LPM	Yes
Sulphur Dioxide (SO ₂)	81-1138RK	81-1051RK, 0.5 LPM	Yes

WARNING: *Not using the recommended 81-1138RK-XX calibration cup, recommended sample flowrate, and specified flow direction will result in an inaccurate calibration of the ESM-01 channel. Make sure to connect the sample tubing to the calibration cup port that results in the specified flow direction for the 81-1138RK-XX calibration cup.*

Preparing for Calibration

1. Unscrew the splashguard from the detector housing cap. Make sure the cap remains securely screwed onto the housing body.
2. Push the calibration cup onto the plug-in sensor that sticks through the housing cap. The calibration cup seals to the sensor with an O-ring.
3. Screw the regulator into the zero air calibration cylinder.
4. Use the sample tubing to connect the regulator to the calibration cup. Make sure to connect the tubing to the inlet side of the calibration cup if using the 81-1138RK calibration cup which is marked on the outside bottom to show the required flow direction through the cup.

NOTE If you can verify that the toxic detector is in a fresh air environment, you do not need to apply zero air to the detector before adjusting the fresh air reading.

5. Put the controller into its calibration program. See the controller operator's manual for instructions to enter the calibration program.

NOTE: RKI controllers have a minimum hold feature for zero adjustment and a peak hold feature for span adjustment. Because of this, the instructions call for turning off the gas to a detector before making adjustments.

Setting the Zero Reading

1. Follow the instructions in the controller operator's manual for setting the zero reading.
2. When the instructions call for applying zero air to the detector, turn the regulator's on/off knob counterclockwise to open it. Gas will begin to flow.
3. Allow the gas to flow for two minutes.
4. Turn the regulator's on/off knob clockwise to close it.
5. Set the fresh air reading according to the controller operator's manual.
6. Unscrew the regulator from the zero air calibration cylinder. Leave the sample tubing connected to the regulator and the calibration cup.

NOTE: Depending on the size of your zero air cylinder, it is possible that you will have a different regulator for the zero air cylinder and toxic gas cylinder. If necessary to fit the calibration toxic gas cylinder, change the regulator.

Setting the Response Reading

1. Screw the regulator into the calibration gas cylinder.
2. Follow the directions in the controller operator's manual for setting the response (span) reading.
3. When the directions call for exposing the detector to gas, turn the regulator's on/off knob counterclockwise to open it. Gas will begin to flow.
4. Allow the gas to flow to the detector for 2 minutes.
5. Turn the regulator's on/off knob clockwise to turn it off.
6. Set the response reading according to the controller operator's manual.

Returning to Normal Operation

1. Unscrew the regulator from the cylinder and gently pull the calibration cup off of the plug-in sensor.

NOTE: For convenience, leave the regulator and calibration cup connected by the sample tubing.

2. Allow about 45 seconds for the gas reading to decrease below the alarm points and then return the controller to normal operation.

NOTE: If you do not allow the gas reading to decrease below the alarm points, then unwanted alarms may occur.

3. Verify that the controller display reading decreases and stabilizes at 0 ppm.
4. Store the components of the calibration kit in a safe and convenient place.

Parts List

Table 5 lists replacement parts and accessories for the multi-point detector.

Table 4: Parts List

Part Number	Description
06-1248RK-03	Calibration kit sample tubing, 3 ft. length
07-0033RK	Detector housing cap gasket (for O ₂ , H ₂ S, and CO detectors)
07-0203RK	Rubber retaining boot
14-2101RK	Spacer between H ₂ S sensor and rubber boot
61-0140RK	Catalytic LEL replacement detector
61-0190RK-CH ₄	IR CH ₄ LEL replacement detector
61-0190RK-HC	IR HC LEL replacement detector
65-1025RK	Oxygen replacement plug-in sensor
65-2300RK-ASH ₃	Replacement detector assembly, AsH ₃ (includes plug-in sensor)
65-2300RK-CL ₂	Replacement detector assembly, Cl ₂ (includes plug-in sensor)
65-2300RK-HCN	Replacement detector assembly, HCN (includes plug-in sensor)
65-2300RK-NH ₃	Replacement detector assembly, NH ₃ (includes plug-in sensor)
65-2300RK-PH ₃	Replacement detector assembly, PH ₃ (includes plug-in sensor)
65-2300RK-SO ₂	Replacement detector assembly, SO ₂ (includes plug-in sensor)
65-2428	H ₂ S replacement detector assembly (includes sensor)
65-2438	CO replacement detector assembly (includes sensor)
65-2484RK-01	Multi-point detector assembly, LEL/O ₂ /H ₂ S/AsH ₃
65-2484RK-02	Multi-point detector assembly, LEL/O ₂ /H ₂ S/Cl ₂
65-2484RK-03	Multi-point detector assembly, LEL/O ₂ /H ₂ S/HCN
65-2484RK-04	Multi-point detector assembly, LEL/O ₂ /H ₂ S/NH ₃
65-2484RK-05	Multi-point detector assembly, LEL/O ₂ /H ₂ S/PH ₃
65-2484RK-06	Multi-point detector assembly, LEL/O ₂ /H ₂ S/SO ₂
65-2484RK-11	Multi-point detector assembly, LEL (IR CH ₄)/O ₂ /H ₂ S/AsH ₃
65-2484RK-12	Multi-point detector assembly, LEL (IR CH ₄)/O ₂ /H ₂ S/Cl ₂
65-2484RK-13	Multi-point detector assembly, LEL (IR CH ₄)/O ₂ /H ₂ S/HCN
65-2484RK-14	Multi-point detector assembly, LEL (IR CH ₄)/O ₂ /H ₂ S/NH ₃
65-2484RK-15	Multi-point detector assembly, LEL (IR CH ₄)/O ₂ /H ₂ S/PH ₃

Table 4: Parts List

Part Number	Description
65-2484RK-16	Multi-point detector assembly, LEL (IR CH ₄)/O ₂ /H ₂ S/SO ₂
65-2484RK-21	Multi-point detector assembly, LEL/H ₂ S/CO/AsH ₃
65-2484RK-22	Multi-point detector assembly, LEL/H ₂ S/CO/Cl ₂
65-2484RK-23	Multi-point detector assembly, LEL/H ₂ S/CO/HCN
65-2484RK-24	Multi-point detector assembly, LEL/H ₂ S/CO/NH ₃
65-2484RK-25	Multi-point detector assembly, LEL/H ₂ S/CO/PH ₃
65-2484RK-26	Multi-point detector assembly, LEL/H ₂ S/CO/SO ₂
65-2484RK-31	Multi-point detector assembly, LEL (IR CH ₄)/H ₂ S/CO/AsH ₃
65-2484RK-32	Multi-point detector assembly, LEL (IR CH ₄)/H ₂ S/CO/Cl ₂
65-2484RK-33	Multi-point detector assembly, LEL (IR CH ₄)/H ₂ S/CO/HCN
65-2484RK-34	Multi-point detector assembly, LEL (IR CH ₄)/H ₂ S/CO/NH ₃
65-2484RK-35	Multi-point detector assembly, LEL (IR CH ₄)/H ₂ S/CO/PH ₃
65-2484RK-36	Multi-point detector assembly, LEL (IR CH ₄)/H ₂ S/CO/SO ₂
65-2484RK-41	Multi-point detector assembly, LEL/O ₂ /CO/AsH ₃
65-2484RK-42	Multi-point detector assembly, LEL/O ₂ /CO/Cl ₂
65-2484RK-43	Multi-point detector assembly, LEL/O ₂ /CO/HCN
65-2484RK-44	Multi-point detector assembly, LEL/O ₂ /CO/NH ₃
65-2484RK-45	Multi-point detector assembly, LEL/O ₂ /CO/PH ₃
65-2484RK-46	Multi-point detector assembly, LEL/O ₂ /CO/SO ₂
65-2484RK-51	Multi-point detector assembly, LEL (IR CH ₄)/O ₂ /CO/AsH ₃
65-2484RK-52	Multi-point detector assembly, LEL (IR CH ₄)/O ₂ /CO/Cl ₂
65-2484RK-53	Multi-point detector assembly, LEL (IR CH ₄)/O ₂ /CO/HCN
65-2484RK-54	Multi-point detector assembly, LEL (IR CH ₄)/O ₂ /CO/NH ₃
65-2484RK-55	Multi-point detector assembly, LEL (IR CH ₄)/O ₂ /CO/PH ₃
65-2484RK-56	Multi-point detector assembly, LEL (IR CH ₄)/O ₂ /CO/SO ₂
65-2514RK	Oxygen replacement detector assembly (includes sensor)
71-0252RK	<i>65-2484RK Multi Point Detector Operator's Manual (this document)</i>
81-0004RK	Calibration cylinder, 50% LEL propane in air, 17 liter steel
81-0004RK-01	Calibration cylinder, 50% LEL propane in air, 34 liter steel

Table 4: Parts List

Part Number	Description
81-0004RK-03	Calibration cylinder, 50% LEL propane in air, 103 liter steel
81-0007RK	Calibration cylinder, 15% LEL hexane in air, 34 liter steel
81-0007RK-01	Calibration cylinder, 15% LEL hexane in air, 103 liter steel
81-0012RK	Calibration cylinder, 50% LEL methane in air, 17 liter steel
81-0012RK-01	Calibration cylinder, 50% LEL methane in air, 34 liter steel
81-0012RK-03	Calibration cylinder, 50% LEL methane in air, 103 liter steel
81-0018RK	Calibration cylinder, 50% LEL isobutane in air, 17 liter steel
81-0018RK-01	Calibration cylinder, 50% LEL isobutane in air, 34 liter steel
81-0018RK-03	Calibration cylinder, 50% LEL isobutane in air, 103 liter steel
81-0064RK-01	Calibration cylinder, 50 ppm CO in air, 34 liter steel
81-0064RK-03	Calibration cylinder, 50 ppm CO in air, 103 liter steel
81-0076RK	Zero air calibration cylinder, 17 liter steel
81-0076RK-01	Zero air calibration cylinder, 34 liter steel
81-0076RK-03	Zero air calibration cylinder, 103 liter steel
81-0078RK-01	Calibration cylinder, 100% nitrogen, 34 liter
81-0078RK-03	Calibration cylinder, 100% nitrogen, 103 liter
81-0151RK-02	Calibration cylinder, 25 ppm H ₂ S in nitrogen, 58 liter aluminum
81-0151RK-04	Calibration cylinder 25 ppm H ₂ S in nitrogen, 34 liter aluminum
81-0154RK-02	Calibration cylinder, 4-gas mix (CH ₄ / O ₂ / CO/ H ₂ S), 58 liter aluminum
81-0154RK-04	Calibration cylinder, 4-gas mix (CH ₄ / O ₂ / CO/ H ₂ S), 34 liter aluminum
81-0170RK-02	Calibration cylinder, 5 ppm SO ₂ in nitrogen, 58 liter aluminum
81-0170RK-04	Calibration cylinder, 5 ppm SO ₂ in nitrogen, 34 liter aluminum
81-0175RK-02	Calibration cylinder, 10 ppm NH ₃ in nitrogen, 58 liter aluminum
81-0175RK-04	Calibration cylinder, 10 ppm NH ₃ in nitrogen, 34 liter aluminum
81-0185RK-02	Calibration cylinder, 0.5 ppm PH ₃ in nitrogen, 58 liter aluminum, used to calibrate PH ₃ and AsH ₃ detectors, see conversion factor on AsH ₃ plug-in sensors
81-0185RK-04	Calibration cylinder, 0.5 ppm PH ₃ in nitrogen, 34 liter aluminum, used to calibrate PH ₃ and AsH ₃ detectors, see conversion factor on AsH ₃ plug-in sensors
81-0192RK-02	Calibration cylinder, 2 ppm Cl ₂ in nitrogen, 58 liter, aluminum
81-0192RK-04	Calibration cylinder, 2 ppm Cl ₂ in nitrogen, 34 liter aluminum

Table 4: Parts List

Part Number	Description
81-0196RK-02	Calibration cylinder, 10 ppm HCN in nitrogen, 58 liter aluminum
81-0196RK-04	Calibration cylinder, 10 ppm HCN in nitrogen, 34 liter aluminum
81-1050RK	Regulator with gauge and knob, 0.5 LPM, for 17 liter and 34 liter steel calibration cylinders
81-1051RK	Regulator with gauge and knob, 0.5 LPM, for 34AL/58/103 liter calibration cylinders
81-1103RK	Calibration cup for IR LEL detector
81-1117RK	Calibration cup for catalytic LEL, O ₂ , CO, and H ₂ S detectors
81-1138RK	Calibration cup, general (SO ₂), for ESM-01, use 0.5 LPM flow
81-1138RK-CL2	Calibration cup, for ESM-01 Cl ₂ , use 0.5 LPM flow
81-1138RK-NH3	Calibration cup, for ESM-01 NH ₃ , use 0.25 LPM flow
ES-1537-H2S	H ₂ S replacement plug-in sensor
ESM-01DH-ASH3	ESM-01 plug-in sensor, 0 - 1.50 ppm arsine
ESM-01DH-D-HCN	ESM-01 plug-in sensor, 0 - 15.0 ppm hydrogen cyanide
ESM-01DH-D-SO2	ESM-01 plug-in sensor, 0 - 6.00 ppm sulphur dioxide, diffusion type only
ESM-01DH-PH3	ESM-01 plug-in sensor, 0 - 1.00 ppm phosphine
ESM-01R-D-NH3	ESM-01 plug-in sensor, 0 - 75.0 ppm ammonia, diffusion type only
ESM-K01-D-CL2	ESM-01 plug-in sensor, 0 - 3.00 ppm chlorine, diffusion type only