



**INSTRUMENTS**

**65-2398RK**  
**Combustible Gas Transmitter**  
**Operator's Manual**

*Part Number: 71-0196RK*

*Revision: A*

*Released: 4/12/11*

## **WARNING**

Read and understand this instruction manual before operating transmitter. Improper use of the transmitter could result in bodily harm or death.

Periodic calibration and maintenance of the transmitter is essential for proper operation and correct readings. Please calibrate and maintain this transmitter regularly! Frequency of calibration depends upon the type of use you have and the sensor types. Typical calibration frequencies for most applications are between 6 and 12 months, but can be required more often or less often based on your usage.

---

## Product Warranty

RKI Instruments, Inc. warrants gas alarm equipment sold by us to be free from defects in materials, workmanship, and performance for a period of one year from date of shipment from RKI Instruments, Inc. Any parts found defective within that period will be repaired or replaced, at our option, free of charge. This warranty does not apply to those items which by their nature are subject to deterioration or consumption in normal service, and which must be cleaned, repaired, or replaced on a routine basis. Examples of such items are:

- a) Absorbent cartridges
- b) Pump diaphragms and valves
- c) Fuses
- d) Batteries
- e) Filter elements

Warranty is voided by abuse including mechanical damage, alteration, rough handling, or repair procedures not in accordance with the operator's manual. This warranty indicates the full extent of our liability, and we are not responsible for removal or replacement costs, local repair costs, transportation costs, or contingent expenses incurred without our prior approval.

*THIS WARRANTY IS EXPRESSLY IN LIEU OF ANY AND ALL OTHER WARRANTIES AND REPRESENTATIONS, EXPRESSED OR IMPLIED, AND ALL OTHER OBLIGATIONS OR LIABILITIES ON THE PART OF RKI INSTRUMENTS, INC. INCLUDING BUT NOT LIMITED TO, THE WARRANTY OF MERCHANTABILITY OR FITNESS FOR A PARTICULAR PURPOSE. IN NO EVENT SHALL RKI INSTRUMENTS, INC. BE LIABLE FOR INDIRECT, INCIDENTAL, OR CONSEQUENTIAL LOSS OR DAMAGE OF ANY KIND CONNECTED WITH THE USE OF ITS PRODUCTS OR FAILURE OF ITS PRODUCTS TO FUNCTION OR OPERATE PROPERLY.*

This warranty covers instruments and parts sold to users by authorized distributors, dealers, and representatives as appointed by RKI Instruments, Inc.

We do not assume indemnification for any accident or damage caused by the operation of this gas monitor, and our warranty is limited to the replacement of parts or our complete goods.

---

## Table of Contents

<b>Overview</b> .....	<b>1</b>
<b>Specifications</b> .....	<b>1</b>
<b>Description</b> .....	<b>2</b>
Combustible Gas Detector .....	3
Amplifier .....	3
Junction Box .....	4
<b>Installation</b> .....	<b>5</b>
Mounting the Combustible Gas Transmitter .....	5
Wiring the Combustible Gas Transmitter .....	6
<b>Startup</b> .....	<b>8</b>
Introducing Incoming Power .....	8
Setting the Zero Signal .....	8
<b>Maintenance</b> .....	<b>9</b>
Preventive Maintenance .....	9
Troubleshooting .....	11
Replacing Components of the Combustible Gas Transmitter .....	12
<b>Calibration Frequency</b> .....	<b>15</b>
<b>Calibration</b> .....	<b>15</b>
Preparing for Calibration .....	16
Setting the Zero Reading .....	16
Setting the Response Reading .....	16
Returning to Normal Operation .....	17
<b>Parts List</b> .....	<b>18</b>

---

## Overview

This manual describes the 65-2398RK combustible gas transmitter. This manual also describes how to install, start up, configure, maintain, and calibrate the transmitter when it is used with a gas monitoring controller. A parts list at the end of this manual lists replacement parts and accessories for the combustible gas transmitter.

---

## Specifications

Table 1 lists specifications for the combustible gas transmitter.

**Table 1: Specifications**

Description	Specification
Target Gas	65-2398RK-CH4: Methane (CH <sub>4</sub> ) 65-2398RK-HC: Propane
Sampling Method	Diffusion
Signal Output	4 to 20 mA
Detection Range	0 to 100% LEL
Response Time	90% in 45 seconds
Operating Temperature	-4°F to 122°F (-20°C to 50°C)
Accuracy	± 5% of reading or ± 2% of full scale (whichever is greater)

---

**WARNING:** *When using the 65-2398RK, you must follow the instructions and warnings in this manual to assure proper and safe operation of the 65-2398RK and to minimize the risk of personal injury. Be sure to maintain and periodically calibrate the 65-2398RK as described in this manual.*

---

## Description

The 65-2398RK combustible gas transmitter has two versions, the 65-2398RK-CH4 which is calibrated to methane and the 65-2398RK-HC which is calibrated to propane. The transmitter utilizes an infrared type of detector which has some advantages over a catalytic type of combustible detector. The infrared detector will generally have a longer service life than a catalytic detector, it will require calibration less often, and it can detect combustible gas even if there is no oxygen in the sample which allows detection of combustible gas in an inert atmosphere.

This section describes the components of the combustible gas transmitter. The transmitter is a 4 - 20 mA type detector head. It consists of the combustible gas detector, amplifier, and junction box.

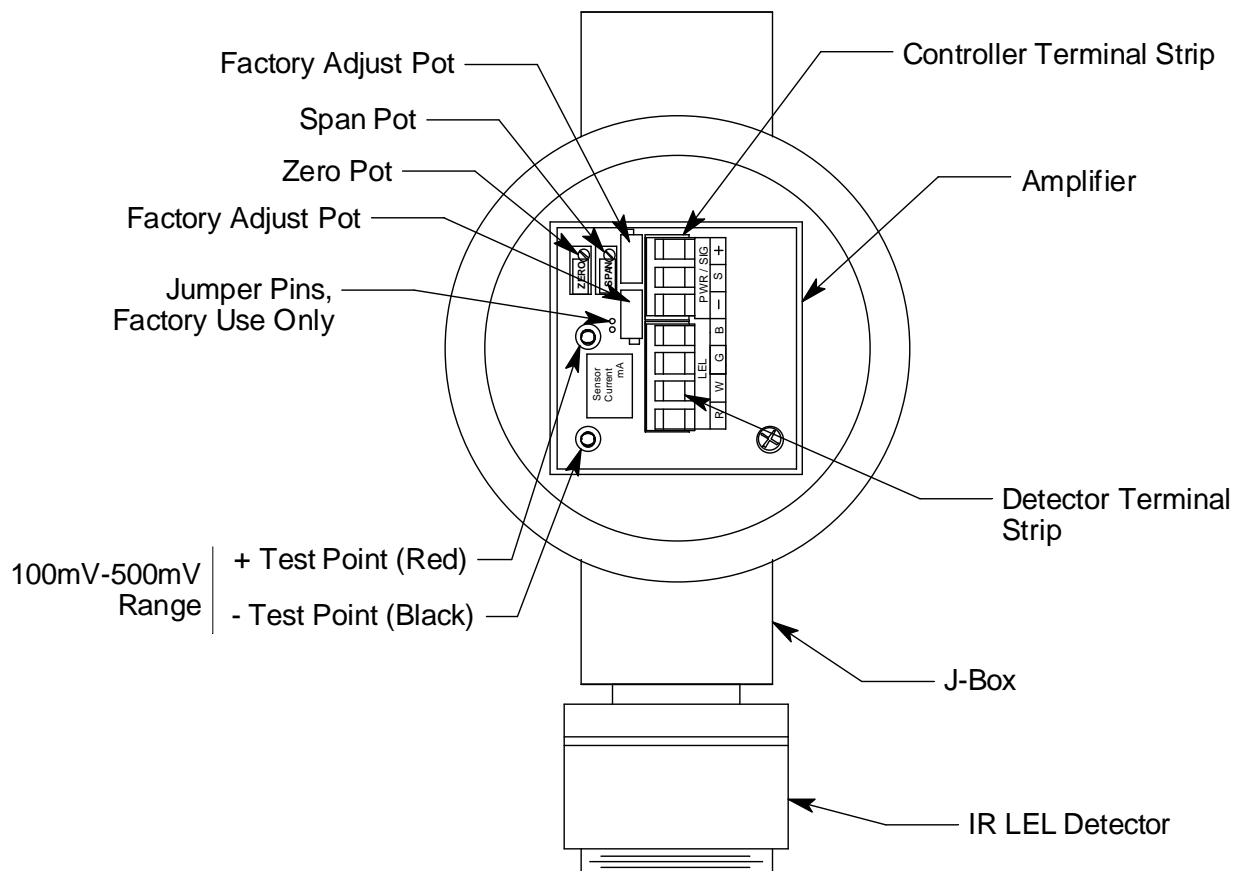

Figure 1: Combustible Gas Transmitter Component Location

## Infrared LEL Detector

The infrared LEL detector consists of the detector housing body, detector housing cap, cap gasket, and the plug-in sensor.

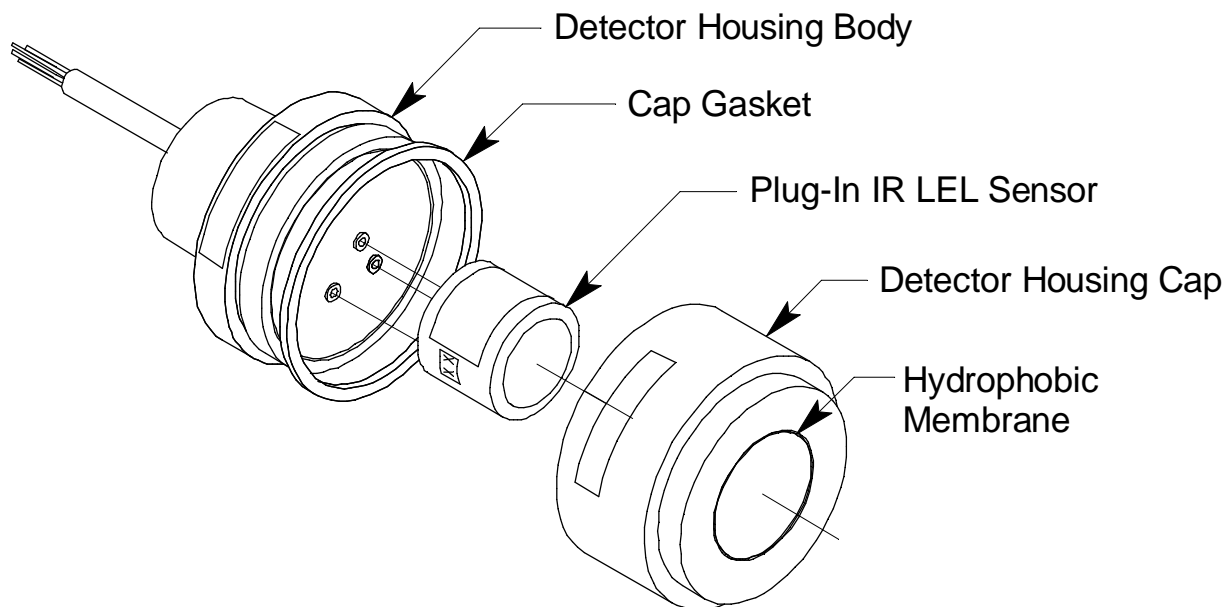

Figure 2: Infrared LEL Detector Component Location

### ***Detector Housing Body***

The detector housing body protects the electronic components within the housing. Use the mounting threads at the top of the housing to screw the IR LEL detector into the 3/4" NPT hub on the bottom of the junction box. Four color coded leads, red, white, green, and black, extend from the other end of the detector. The leads allow you to connect the detector to the amplifier.

The housing includes three sockets installed on a circuit board. These sockets accept the plug-in sensor's three pins to provide an electrical connection for the sensor. The circuit board with the sockets conditions the sensor's signal before the signal reaches the amplifier.

### ***Housing Cap & Cap Gasket***

The housing cap screws onto the detector housing body. It retains the plug-in sensor and protects it from damage. A foam gasket is installed inside the housing cap that seals against the sensor face. A hydrophobic membrane on the outside of the cap face keeps water and particulates away from the sensor face behind the cap. Unscrew the detector cap to access the plug-in sensor for maintenance or replacement. A cap gasket seals the interface between the housing body and cap.

### ***Plug-In LEL Sensor***

The plug-in sensor is secured in the detector assembly by the housing cap. The sensor produces a millivolt output that corresponds to the detection range of the transmitter.

## Amplifier

The amplifier converts the electrical output from the detector to a 4 to 20 mA signal that corresponds to the detection range and transmits the signal to a gas monitoring controller. A foam gasket that orients the amplifier and keeps it from rotating is installed on the bottom of the amplifier. A label on the amplifier indicates the detector drive current. The detector drive current is factory set to 148 mA for the 65-2398RK. The amplifier includes the detector terminal strip, controller terminal strip, span pot, zero pot, and test points (see Figure 1).

### **Controller Terminal Strip**

The controller terminal strip is a three position plug-in style terminal strip located near the top of the amplifier. Use the controller terminal strip to wire the combustible gas transmitter to a controller.

### **Detector Terminal Strip**

The detector terminal strip is a four position plug-in style terminal strip located below the controller terminal strip. Use the detector terminal strip to connect the IR LEL detector to the amplifier.

---

**NOTE:** The IR LEL detector is factory-wired to the detector terminal strip. See “Wiring the Combustible Gas Transmitter to a Controller” on page 6 for all wiring procedures related to the transmitter.

---

### **Zero Pot**

The zero pot is located in the upper left corner of the amplifier (see Figure 1). Use a small flat blade screwdriver to turn the zero pot’s adjustment screw and adjust the amplifier’s zero (fresh air) output during the start-up and calibration procedures. Turn the adjustment screw clockwise to increase the zero output and counterclockwise to decrease the zero output.

### **Span Pot**

The span pot is located to the right of the zero pot (see Figure 1). Use a small flat blade screwdriver to turn the span pot’s adjustment screw and adjust the amplifier’s gas response output during the calibration procedure. Turn the adjustment screw clockwise to increase the gas response and counterclockwise to decrease the gas response.

---

**CAUTION:** *The amplifier includes two additional potentiometers. They are factory-set. Do not adjust them.*

---

### **Test Points**

The test points are on the left side of the amplifier (see Figure 1). The test points produce a 100 mV to 500 mV output that corresponds to the transmitter’s 4 to 20 mA output. Use the test points and a voltmeter to measure the amplifier’s output during the start-up and calibration procedures. The black test point in the lower left corner is the negative (-) test point and the red test point below the zero pot is the positive (+) test point.

## Junction Box

Use the junction box to install the transmitter at a mounting site that is remote from the controller. The junction box protects the amplifier and wiring connections made to the amplifier. Use the top 3/4” conduit hub to connect wiring from the amplifier to the controller. Use the cover on the front of the junction box to access the interior of the



junction box. The detector and amplifier are factory installed in the junction box. Three spacers installed on the back of the junction box control the distance of the junction box from a mounting surface and ensure that there is enough room to install a calibration cup on the detector during calibration.

## Installation

This section describes procedures to mount the combustible gas transmitter in the monitoring environment and wire the transmitter to a controller.

### Mounting the Combustible Gas Transmitter

1. Select a mounting site that is representative of the monitoring environment. Consider the following when you select the mounting site.
  - Select a site where the transmitter is not likely to be bumped or disturbed. Make sure there is sufficient room to perform start-up, maintenance, and calibration procedures.
  - Select a site where the target gas is likely to be found first. For lighter gases, mount the detector near the ceiling; for heavier gases, mount the detector near the floor.

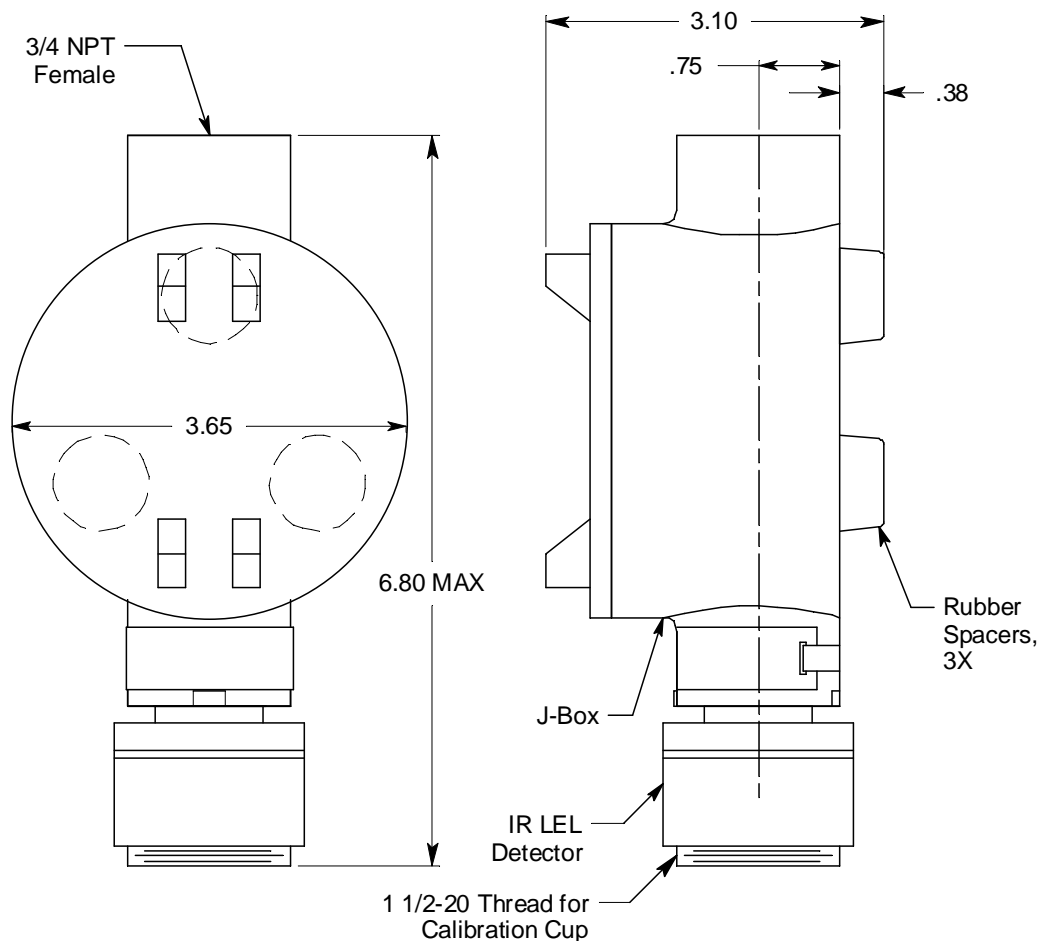

Figure 3: Mounting the Combustible Gas Transmitter

2. At the monitoring site you select, hang or mount the junction box with the detector

facing down (see Figure 3).

## Wiring the Combustible Gas Transmitter to a Controller

---

**WARNING:** *Always verify that the power to the controller is off before you make wiring connections.*

---

1. Turn off the controller.
  2. Turn off or unplug power to the controller.
  3. Remove the junction box cover.
  4. The detector leads are factory wired. Verify that the detector leads are wired to the amplifier's detector terminal strip as shown in Figure 4.
  5. To gain access to a plug-in terminal strip for wiring, pull it out of its socket by grasping the terminal strip and pulling. The socket for the detector strip and the plug for the controller strip are keyed so that the controller and detector terminal strips cannot be reversed inadvertently.
  6. Guide a three-conductor, shielded cable, or three wires in conduit through the top conduit hub of the junction box. Use appropriate conduit fittings and construction technique for the environmental rating of the junction box. The junction box is rated NEMA 4X.
  7. Pull out the controller terminal strip, and connect the three wires to the terminal strip as follows (see Figure 4).
    - Connect the positive wire to the **PWR/SIG “+”** terminal.
    - Connect the signal wire to the **PWR/SIG “S”** terminal.
    - Connect the negative wire to the **PWR/SIG “-”** terminal.
- 

**CAUTION:** *If shielded cable is used, leave the cable shield's drain wire disconnected and insulated at the transmitter. You will connect the opposite end of the cable's drain wire to the controller's chassis (earth) ground.*

---

8. Reinstall the controller terminal strip into its socket.
  9. Secure the junction box cover to the junction box.
  10. Route the cable or wires leading from the combustible gas transmitter through one of the conduit hubs at the controller housing. Use appropriate conduit fittings and construction technique for the environmental rating of the controller. RKI controllers are typically rated NEMA 4X.
- 

**CAUTION:** *Do not route power and transmitter wiring through the same controller conduit hub. The power cable may disrupt the transmission of the transmitter signal to the controller.*

---

11. Connect the wires to the applicable detector/transmitter terminal strip at the controller as shown in Figure 4.

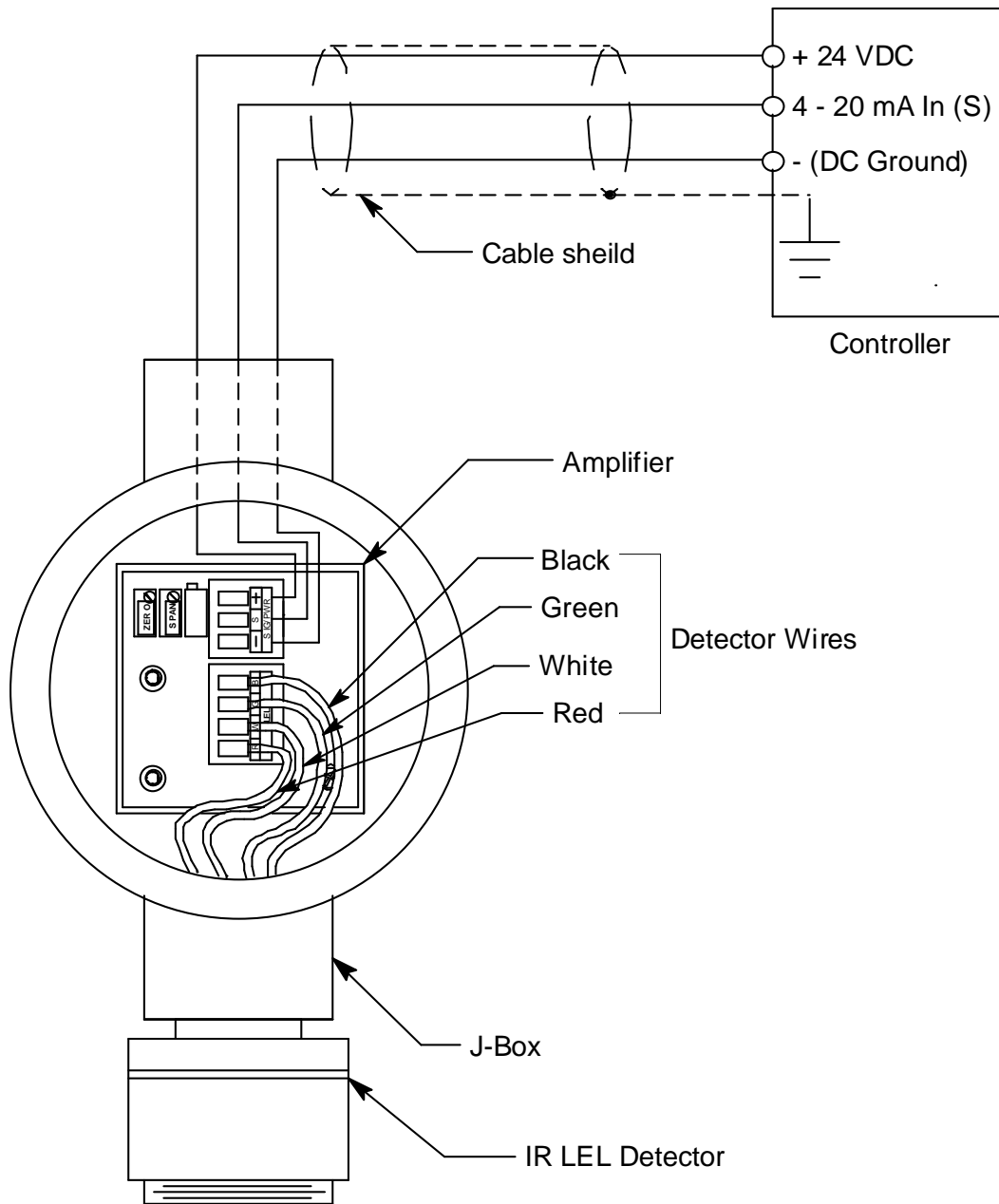

**Figure 4: Wiring the Combustible Gas Transmitter to a Controller**

12. If shielded cable is used, connect the cable's drain wire to an available chassis (earth) ground at the controller. RKI controllers typically have a ground stud that can be used to ground the cable's drain wire.

---

## Start Up

This section describes procedures to start up the combustible gas transmitter and place the transmitter into normal operation.

### Introducing Incoming Power

1. Complete the installation procedures described earlier in this manual.
2. Verify that the power wiring to the controller is correct and secure. Refer to the controller operator's manual.
3. Turn on power to the controller.
4. Turn on the controller.
5. Verify that the controller is on and operating properly. Refer to the controller operator's manual.

---

**NOTE:** When first powered up, the transmitter will enter about a one minute period when the 4-20 mA output is stabilizing and may be above the controller alarm points or well below zero momentarily. RKI controllers have a one minute warmup period when the controller does not display any gas reading or give any alarm indication. The combustible gas transmitter's 4-20 mA signal should be stable by the time the controller's warmup period is over.

---

---

**CAUTION:** *Allow the detector to warm up for 5 minutes before you continue with the next section, "Setting the Zero Signal".*

---

### Setting the Zero Signal

---

**NOTE:** If you can verify that the combustible gas transmitter is in a fresh air environment, you do not need to apply zero air to the detector before adjusting the zero reading.

---

The procedure below describes applying zero emission air, usually called zero air, using a calibration kit that includes a calibration cup, calibration gas, sample tubing, and a fixed flow regulator with an on/off knob. RKI Instruments, Inc. recommends using a 0.5 LPM (liters per minute) fixed flow regulator.

1. Unscrew and remove the junction box cover from the junction box.
2. Set a voltmeter to measure in the millivolt (mV) range.
3. Plug the voltmeter leads into the test points on the amplifier. Plug the positive lead into the red (+) test point; plug the negative lead into the black (-) test point.
4. Screw the calibration cup onto the bottom of the IR LEL detector.
5. Screw the regulator into the zero air calibration cylinder.
6. Use the calibration kit sample tubing to connect the regulator to the calibration cup.
7. Turn the regulator's on/off knob counterclockwise to open it. Gas will begin to flow.
8. Allow the gas to flow for one minute.
9. Verify a voltmeter reading of 100 mV ( $\pm 2$  mV).
10. If necessary, use a small flat-blade screwdriver to adjust the zero pot until the

voltmeter reading is 100 mV ( $\pm 2$  mV).

11. Turn the regulator's on/off knob clockwise to close it.
12. Unscrew the calibration cup from the detector.
13. Unscrew the regulator from the zero air calibration cylinder. For convenience, leave the sample tubing connected to the regulator and the calibration cup.
14. Store the components of the calibration kit in a safe and convenient place.
15. Remove the voltmeter leads from the test points.
16. Secure the junction box cover to the junction box.

---

## Maintenance

This section describes maintenance procedures. It includes preventive maintenance, troubleshooting, and component replacement procedures.

### Preventive Maintenance

This section describes a preventive maintenance schedule to ensure the optimum performance of the combustible gas transmitter. It includes daily, monthly, and biannual procedures.

#### *Daily*

Verify a display reading of 0 %LEL at the controller. Investigate significant changes in the display reading.

#### *Monthly*

This procedure describes a test to verify that the combustible gas transmitter responds properly to the target gas.

---

**WARNING:** *The controller is not an active gas monitoring device during the response test procedure.*

---

---

**NOTE:** Performing a response test on the combustible gas transmitter may cause alarms. Be sure to put the controller into its calibration mode or disable external alarms before performing this test.

---

---

**NOTE:** The following procedure assumes the use of a calibration kit which includes a calibration gas cylinder, a 0.5 LPM fixed flow regulator with an on/off knob, a calibration cup for the detector, and a length of sample tubing.

---

#### *Preparing for the response test*

1. Place the controller into its calibration mode or disable external alarms.
2. Verify that the controller display reading for the channel you are testing is 0 %LEL.  
If the display reading is not 0 %LEL, set the zero reading of the transmitter as described in "Start Up" on page 8, then continue this procedure.
3. Screw the regulator into the calibration cylinder.
4. Screw the calibration cup onto the bottom of the detector.

5. Use the calibration kit sample tubing to connect the regulator to the calibration cup.
6. Set a voltmeter to measure in the millivolt (mV) range.
7. Plug the voltmeter leads into the test points on the amplifier. Plug the positive lead into the red (+) test point; plug the negative lead into the black (-) test point.
8. Use the following formula to determine the correct test points output for the test sample.

$$\text{Output (mV)} = (\text{calibrating sample/fullscale}) \times 400 + 100$$

For example, with a test sample of 50 %LEL and a fullscale setting of 100 %LEL, the correct output is 300 mV.

$$300 \text{ (mV)} = (50/100) \times 400 + 100$$

#### Performing the response test

1. Turn the regulator's on/off knob counterclockwise to open the regulator. Gas will begin to flow.
2. Allow the gas to flow for one minute.
3. Verify that the reading is within  $\pm 20\%$  of the response reading you determined earlier.

---

**NOTE:** If the reading is not within  $\pm 20\%$  of the correct response reading, calibrate the transmitter as described in "Calibration" on page 15 of this manual.

---

4. Turn the regulator's on/off knob clockwise to close the regulator.
5. Unscrew the regulator from the calibration cylinder.
6. Unscrew the calibration cup from the detector.

---

**NOTE:** For convenience, leave the regulator and calibration cup connected by the sample tubing.

---

7. Remove the voltmeter leads from the amplifier test points.
8. Reinstall the junction box cover.
9. When the controller display reading falls below the alarm setpoints, return the controller to normal operation.
10. Store the components of the calibration kit in a safe place.

#### **Biannually**

Calibrate the combustible gas transmitter as described in "Calibration" on page 15 of this manual.

## Troubleshooting

The troubleshooting guide describes symptoms, probable causes, and recommended action for problems you may encounter with the combustible gas transmitter.

**NOTE:** This troubleshooting guide describes transmitter problems only. See the controller operator's manual for problems you may encounter with the controller.

**Table 2: Troubleshooting the Combustible Gas Transmitter**

Condition	Symptom(s)	Probable Causes	Recommended Action
Fail Condition	<ul style="list-style-type: none"> <li>Controller indicates a fail condition.</li> </ul>	<ul style="list-style-type: none"> <li>The transmitter wiring is disconnected or misconnected.</li> <li>The wiring from the detector to the amplifier is disconnected or misconnected.</li> <li>The plug-in sensor is not properly plugged into the 3 socket pattern in the detector housing body.</li> <li>The transmitter's zero reading is low enough to cause a fail condition.</li> <li>The transmitter is malfunctioning.</li> </ul>	<ol style="list-style-type: none"> <li>Verify that the transmitter wiring is correct and secure.</li> <li>Verify that the wiring from the detector to the amplifier is correct and secure.</li> <li>Confirm that the plug-in sensor is properly installed.</li> <li>Perform a zero adjustment. A full calibration is recommended.</li> <li>If the fail condition continues, replace the sensor as described later in this section.</li> <li>If the fail condition continues, contact RKI for further instruction.</li> </ol>
Slow or No Response/ Difficult or Unable to Calibrate	<ul style="list-style-type: none"> <li>Transmitter responds slowly or does not respond to response test.</li> <li>Unable to accurately set the zero or response reading during calibration.</li> <li>Transmitter requires frequent calibration.</li> </ul> <p><b>Note:</b> Under "normal" circumstances, the transmitter requires calibration once every 6 months. Some applications may require a more frequent calibration schedule.</p>	<ul style="list-style-type: none"> <li>The calibration cylinder is low, out-dated, or defective.</li> <li>The calibration gas is not an appropriate concentration.</li> <li>The membrane on the detector housing cap is blocked with dirt or some other particulate matter.</li> <li>The transmitter is malfunctioning.</li> </ul>	<ol style="list-style-type: none"> <li>Verify that the calibration cylinder contains an adequate supply of a fresh test sample.</li> <li>Verify that the calibration gas concentration is appropriate for the transmitter.</li> <li>Check the face of the detector housing cap and remove any particulate contamination from the hydrophobic membrane if necessary. If membrane appears saturated with contamination or damaged, replace the membrane as described in the next section.</li> <li>If the calibration/response difficulties continue, replace the sensor as described later in this section.</li> <li>If the calibration/response difficulties continue, contact RKI for further instruction.</li> </ol>

## Replacing Components of the Combustible Gas Transmitter

This section includes a procedure to replace the hydrophobic membrane, a procedure to replace the plug-in IR LEL sensor, a procedure to replace the entire combustible gas detector assembly, and one to replace the amplifier. In most cases, it is not necessary to replace the entire detector assembly.

### ***Replacing the Hydrophobic Membrane***

1. Turn off the controller.
2. Turn off or unplug incoming power to the controller.
3. Unscrew the detector housing cap from the detector housing body.
4. Gently pry up the edge of the white hydrophobic membrane with a small flat blade screwdriver or a similar tool.
5. Peel off the hydrophobic membrane. It may be necessary to clean off the detector housing cap face to remove any residue left from the adhesive backed membrane.
6. Install the new membrane in the recess on the face of the detector housing cap.
7. Make sure the cap gasket is in place and screw the detector housing cap back onto the detector housing body.
8. Turn on the power to the controller.
9. Turn on the controller and place it into normal operation.

---

**NOTE:** When first powered up, the transmitter will enter about a one minute period when the 4-20 mA output is stabilizing and may be above the controller alarm points or well below zero momentarily. RKI controllers have a one minute warmup period when the controller does not display any gas reading or give any alarm indication. The combustible gas transmitter's 4-20 mA signal should be stable by the time the controller's warmup period is over.

---

### ***Replacing the Plug-In IR LEL Sensor***

1. Turn off the controller.
2. Turn off or unplug power to the controller.
3. Unscrew the detector housing cap from the detector housing body. Make sure not to lose the cap gasket.
4. Unplug and remove the plug-in IR LEL sensor.
5. Carefully plug the replacement sensor into the socket pattern that is located in the detector housing.
6. Make sure the cap gasket is in place and screw the detector housing cap back onto the detector housing body.
7. Turn on power to the controller.
8. Turn on the controller and place it into normal operation.



---

**NOTE:** When first powered up, the transmitter will enter about a one minute period when the 4-20 mA output is stabilizing and may be above the controller alarm points or well below zero momentarily. RKI controllers have a one minute warmup period when the controller does not display any gas reading or give any alarm indication. The combustible gas transmitter's 4-20 mA signal should be stable by the time the controller's warmup period is over.

---

---

**CAUTION:** Allow the replacement sensor to warm up for 5 minutes before you continue with the next step.

---

9. Calibrate the transmitter as described in "Calibration" on page 15.

**Replacing the IR LEL Detector**

1. Turn off the controller.
2. Turn off or unplug power to the controller.
3. Remove the junction box cover.
4. Remove the detector terminal strip from its socket.
5. Disconnect the detector leads from the detector terminal strip. Note the position of the color-coded leads as you remove them.
6. Unscrew the detector from the junction box.
7. Guide the detector leads of the replacement detector through the bottom conduit hub of the junction box, then screw the mounting threads of the detector into the conduit hub. If necessary for environmental conditions, apply thread sealant or teflon tape to the hub and/or detector threads to seal them.
8. Connect the detector leads to the detector terminal strip as shown in Table 3 below and Figure 4 on page 7 of this manual.

**Table 3:Reconnecting the Combustible Gas Detector to the Amplifier**

Detector Lead	Detector Terminal Strip
Red	LEL "R"
White	LEL "W"
Green	LEL "G"
Black	LEL "B"

9. Reinstall the detector terminal strip into its socket.
10. Turn on or plug in power to the controller.
11. Turn on the controller and place it into normal operation.

---

**NOTE:** When first powered up, the transmitter will enter about a one minute period when the 4-20 mA output is stabilizing and may be above the controller alarm points or well below zero momentarily. RKI controllers have a one minute warmup period when the controller does not display any gas reading or give any alarm indication. The combustible gas transmitter's 4-20 mA signal should be stable by the time the controller's warmup period is over.

---



---

**CAUTION:** Allow the replacement detector to warm up for 5 minutes before you continue with the next step.

---

12. Calibrate the transmitter as described in "Calibration" on page 15 of this manual.

**Replacing the Amplifier**

1. Turn off the controller.
2. Turn off or unplug power to the controller.
3. Remove the junction box cover.
4. Unplug the detector terminal strip and controller terminal strip from their sockets. You may leave the wires connected to the terminal strips.
5. Unscrew and remove the screw with the flat and lock washers that secures the amplifier to the junction box.
6. Remove the old amplifier.
7. Place the new amplifier in the same position as the old amplifier. A foam gasket that orients the amplifier and keeps it from rotating is installed on the bottom of the amplifier. Make sure the amplifier is seated flat in the junction box.
8. Install the new amplifier into the junction box with the screw, lock washer, and flat washer you removed in Step 5 above.
9. Install the detector and controller terminals strips into their sockets on the new amplifier as shown in Figure 4 on page 7 of this manual. If controller leads or detector leads were removed during this procedure, refer to Table 4 and Table 5 below.

**Table 4:Reconnecting the Amplifier to the Controller**

<b>Amplifier Controller Terminal Strip</b>	<b>Controller Transmitter Terminal Strip (typical)</b>
PWR/SIG "-"	- (DC -)
PWR/SIG "S"	S (4 - 20 mA In)
PWR/SIG "+"	+ 24V

**Table 5:Reconnecting the LEL Detector to the Amplifier**

<b>Amplifier Detector Terminal Strip</b>	<b>Detector Lead</b>
DETECTOR "R"	RED

**Table 5:Reconnecting the LEL  
Detector to the Amplifier**

<b>Amplifier Detector Terminal Strip</b>	<b>Detector Lead</b>
DETECTOR "W"	WHT
DETECTOR "G"	GREEN
DETECTOR "B"	BLK

---

**NOTE:** When a transmitter is first powered up with a new amplifier, the initial output may be either high or below zero depending on the setting of the zero pot. Be sure to make arrangements so that this does not cause unwanted alarms.

---

10. Turn on power to the controller.
11. Turn on the controller and place it into normal operation.

---

**NOTE:** When first powered up, the transmitter will enter about a one minute period when the 4-20 mA output is stabilizing and may be above the controller alarm points or well below zero momentarily. RKI controllers have a one minute warmup period when the controller does not display any gas reading or give any alarm indication. The combustible gas transmitter's 4-20 mA signal should be stable by the time the controller's warmup period is over.

---

12. Allow the transmitter to warm-up for 5 minutes.
13. Calibrate the transmitter as described in "Calibration" on page 15 of this manual.

---

## **Calibration Frequency**

Although there is no particular calibration frequency that is correct for all applications, a calibration frequency of every 6 months is adequate for most infrared combustible gas transmitter applications. Unless experience in a particular application dictates otherwise, RKI Instruments, Inc. recommends a calibration frequency of every 6 months.

If an application is not very demanding, for example detection in a clean, temperature controlled environment where calibration adjustments are minimal at calibration, then a calibration frequency of every 9 to 12 months is adequate.

If an application is very demanding, for example if the environment is not well controlled, then more frequent calibration than every 6 months may be necessary.

---

## **Calibration**

This section describes how to calibrate the combustible gas transmitter. It includes procedures to prepare for calibration, set the zero reading, set the response reading, and return to normal operation.

---

**WARNING:** *The controller is not an active gas monitoring device during the calibration procedure.*

---

---

**NOTE:** The following procedure assumes the use of a calibration kit which includes a calibration gas cylinder, a 0.5 LPM fixed flow regulator with an on/off knob, a calibration cup for the detector, and a short piece of sample tubing to connect the regulator to the calibration cup.

---

### Preparing for Calibration

1. Unscrew and remove the junction box cover.
2. Set a voltmeter to measure in the millivolt (mV) range.
3. Plug the voltmeter leads into the test points on the amplifier. Plug the positive lead into the red (+) test point; plug the negative lead into the black (-) test point.
4. Use the following formula to determine the correct test points output for the calibrating sample.

$$\text{Output (mV)} = (\text{calibrating sample/fullscale}) \times 400 + 100$$

For example, with a calibrating sample of 50 %LEL and a fullscale setting of 100 %LEL, the correct output is 300 mV.

$$300(\text{mV}) = (50/100) \times 400 + 100$$

5. Screw the calibration cup onto the detector housing.
6. Place the controller into its calibration mode or disable external alarms.

---

**NOTE:** Calibrating the combustible gas transmitter may cause alarms. Be sure to put the controller into its calibration mode or disable external alarms before continuing.

---

### Setting the Zero Reading

---

**NOTE:** If you can verify that the combustible gas transmitter is in a fresh air environment, you do not need to apply zero air to the detector before adjusting the zero reading.

---

1. Screw the regulator into the zero air calibration cylinder.
2. Use the calibration kit sample tubing to connect the regulator to the calibration cup.
3. Turn the regulator's on/off knob counterclockwise to open the regulator.
4. Allow the gas to flow for one minute and verify a reading of 100 mV ( $\pm 2$  mV). If necessary, use the zero pot on the amplifier to adjust the reading to 100 mV ( $\pm 2$  mV).
5. Turn the regulator's on/off knob clockwise to close the regulator.
6. Unscrew the regulator from the zero air calibration cylinder.
7. Leave the sample tubing connected to the regulator and the calibration cup.

### Setting the Response Reading

1. Screw the regulator into the calibration cylinder. Verify that the calibration gas is representative of the transmitter's target gas.
2. Turn the regulator's on/off knob counterclockwise to open the regulator.
3. Allow the calibration gas to flow for one minute and verify that the reading matches the response reading ( $\pm 2$  mV) you determined earlier. If necessary, use the span pot on the amplifier to adjust the reading to match the correct response reading.

4. Turn the regulator's on/off knob clockwise to close the regulator.
5. Unscrew the regulator from the calibration cylinder.

### **Returning to Normal Operation**

1. Remove the voltmeter leads from the amplifier test points.
2. Unscrew the calibration cup from the detector.

---

**NOTE:** For convenience, leave the regulator and calibration cup connected by the sample tubing.

---

3. Secure the junction box cover to the junction box.
4. When the controller display reading falls below the alarm setpoints, return the controller to normal operation.
5. Verify that the controller display reading decreases and stabilizes at 0 %LEL.
6. Store the components of the calibration kit in a safe and convenient place.

## Parts List

Table 6 lists replacement parts and accessories for the combustible gas transmitter.

**Table 6:Parts List**

Part Number	Description
06-1248RK	Sample tubing (3/16 in. x 5/16 in.; specify length when ordering)
18-0400RK-01	Junction box with spacers
33-0157RK	Hydrophobic disk membrane for detector cap
57-1053RK	Amplifier with gasket (specify detector part number when ordering)
61-0197RK-CH4	Methane infrared LEL detector
61-0197RK-HC	HC infrared LEL detector (calibrated to propane)
61-5039RK-CH4	Infrared CH <sub>4</sub> replacement plug-in sensor
61-5039RK-HC	Infrared HC replacement plug-in sensor
65-2398RK-CH4	Methane transmitter (includes detector, junction box, and amplifier)
65-2398RK-HC	Propane transmitter (includes detector, junction box, and amplifier)
71-0196RK	<i>65-2398RK Combustible Gas Transmitter Operator's Manual</i> (this document)
81-0004RK-01	Steel calibration cylinder, 50% LEL propane in air, 34-liter
81-0012RK-01	Steel calibration cylinder, 50% LEL methane in air, 34-liter
81-0076RK-01	Steel calibration cylinder, zero emission air, 34-liter
81-1050RK	Regulator, 0.5 liter/minute; with pressure gauge and flow control knob, for 17 liter and 34 liter steel calibration cylinders
81-1103RK	Calibration cup
82-0006RK	Pot adjust screwdriver, for calibration
81-F002RK-LV	Calibration kit, includes regulator, sample tubing, calibration cup, and 34 liter 50 %LEL methane in air steel calibration cylinder
81-F006RK-LV	Calibration kit, includes regulator, sample tubing, calibration cup, and 34 liter 50 %LEL propane in air steel calibration cylinder