



INSTRUMENTS

65-2461RK
PPM Hexane Transmitter
Operator's Manual

Part Number: 71-0144RK

Revision: 0

Released: 2/16/11

RKI Instruments, Inc.
www.rkiinstruments.com

WARNING

Read and understand this instruction manual before operating detector. Improper use of the detector could result in bodily harm or death.

Periodic calibration and maintenance of the detector is essential for proper operation and correct readings. Please calibrate and maintain this detector regularly! Frequency of calibration depends upon the type of use you have and the sensor types. Typical calibration frequencies for most applications are between 6 and 12 months, but can be required more often or less often based on your usage.

Product Warranty

RKI Instruments, Inc. warrants gas alarm equipment sold by us to be free from defects in materials, workmanship, and performance for a period of one year* from the date of shipment from RKI Instruments, Inc. Any parts found defective within that period will be repaired or replaced, at our option, free of charge. Parts must be returned to RKI Instruments, Inc. for repair or replacement. This warranty does not apply to those items which by their nature are subject to deterioration or consumption in normal service, and which must be cleaned, repaired or replaced on a routine basis. Examples of such items are:

- a) Pump diaphragms and valves
- b) Fuses
- c) Batteries
- d) Filter elements

Warranty is voided by abuse including mechanical damage, alteration, rough handling, or repair procedures not in accordance with instruction manual. This warranty indicates the full extent of our liability, and we are not responsible for removal or replacement costs, local repair costs, transportation costs, or contingent expenses incurred without our prior approval.

THIS WARRANTY IS EXPRESSLY IN LIEU OF ANY AND ALL OTHER WARRANTIES AND REPRESENTATIONS, EXPRESSED OR IMPLIED, AND ALL OTHER OBLIGATIONS OR LIABILITIES ON THE PART OF RKI INSTRUMENTS, INC. INCLUDING BUT NOT LIMITED TO, THE WARRANTY OF MERCHANTABILITY OR FITNESS FOR A PARTICULAR PURPOSE. IN NO EVENT SHALL RKI INSTRUMENTS, INC. BE LIABLE FOR INDIRECT, INCIDENTAL OR CONSEQUENTIAL LOSS OR DAMAGE OF ANY KIND CONNECTED WITH THE USE OF ITS PRODUCTS OR FAILURE OF ITS PRODUCTS TO FUNCTION OR OPERATE PROPERLY.

This warranty covers instruments and parts sold to users only by authorized distributors, dealers and representatives as appointed by RKI Instruments, Inc.

We do not assume indemnification for any accident or damage caused by the operation of this gas monitor and our warranty is limited to the replacement of parts or our complete goods. Warranty covers parts and labor performed at RKI Instruments, Inc. only, and does not cover field labor or shipment of parts back to RKI.

Table of Contents

Overview	1
Specifications	1
Description	2
PPM Hexane Detector	2
Amplifier	3
Junction Box	4
Installation	4
Mounting the PPM Hexane Transmitter	4
Wiring the PPM Hexane Transmitter	5
Startup	7
Introducing Incoming Power	7
Transmitter Burn-In Period	7
Setting the Zero Signal	7
Maintenance	8
Preventive Maintenance	8
Troubleshooting	10
Replacing Components of the PPM Hexane Transmitter	10
Setting the Detector Load Voltage	13
Calibration Frequency	14
Calibration	15
Calibration Kit Humidifier Tube	15
Preparing for Calibration	15
Setting the Zero Reading	16
Setting the Response Reading	16
Returning to Normal Operation	16
Parts List	17

Overview

This manual describes the 65-2461RK ppm hexane transmitter. This manual also describes how to install, start up, configure, maintain, and calibrate the transmitter when it is used with a gas monitoring controller. A parts list at the end of this manual lists replacement parts and accessories for the transmitter.

Specifications

Table 1 lists specifications for the ppm hexane transmitter.

Table 1: Specifications

Description	Specification
Target Gas	Combustible Gas, Calibrated to Hexane
Detection Range	0-500 ppm Hexane
Area Classification	Explosionproof for Class I, Groups B, C, and D
Sampling Method	Diffusion
Signal Output	4 to 20 mA
Response Time	90% in 45 seconds

WARNING: *When using the 65-2461RK, you must follow the instructions and warnings in this manual to assure proper and safe operation of the 65-2461RK and to minimize the risk of personal injury. Be sure to maintain and periodically calibrate the 65-2461RK as described in this manual.*

Description

This section describes the ppm hexane transmitter's components. It is a 4 to 20 mA type detector head. It consists of the ppm hexane detector, amplifier, and junction box.

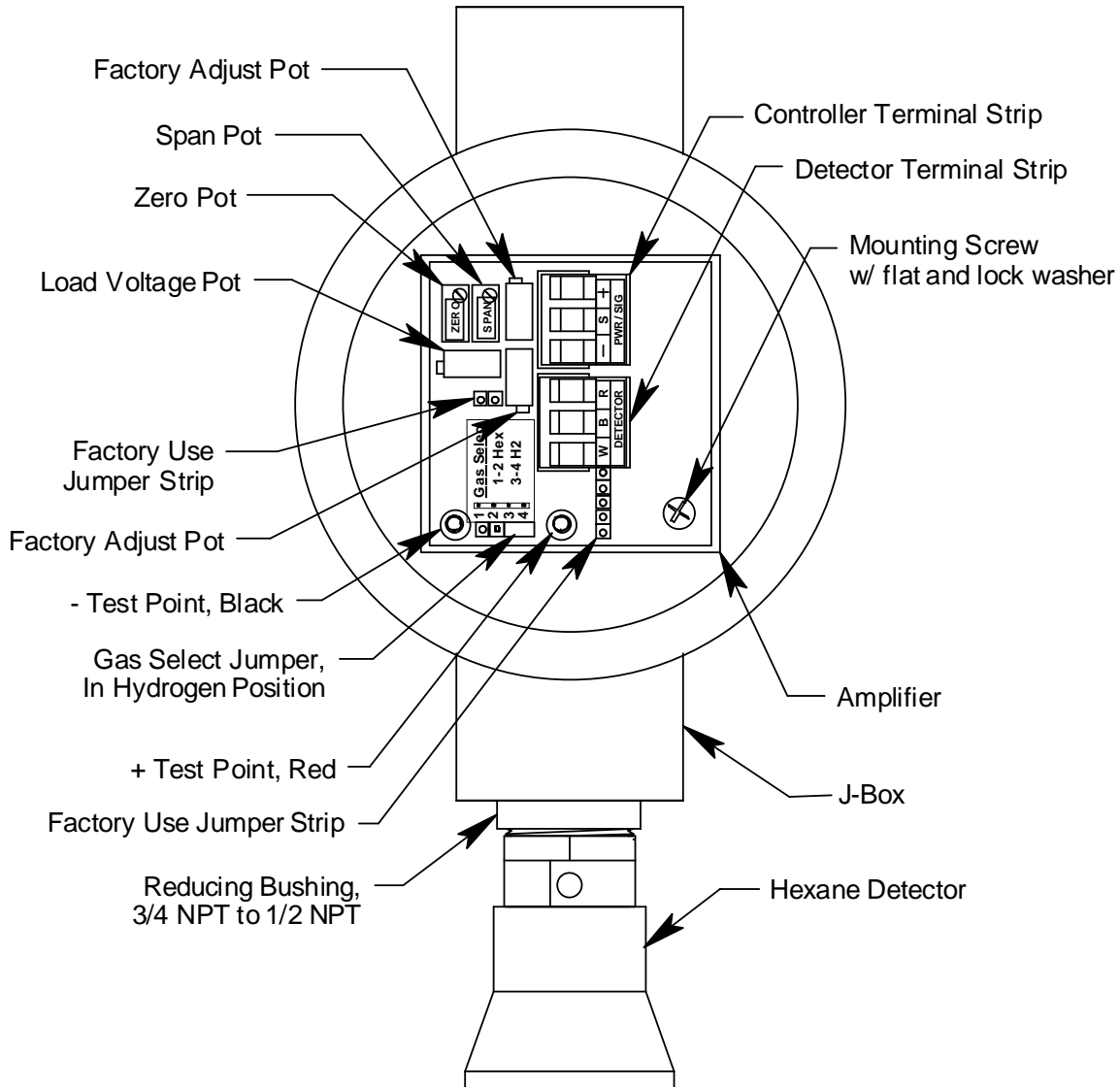

Figure 1: PPM Hexane Transmitter Component Location

PPM Hexane Detector

The ppm hexane detector is a MOS type (metal oxide semiconductor) detector packaged in a 1/2 inch NPT nipple with a sintered metal flame arrestor on one end allowing ambient air to diffuse into the detector. The flame arrestor also contains any sparks which may occur within the detector. The 1/2 inch NPT mounting threads at the top of the detector allow you to mount it into the bottom conduit hub of the junction box. A rainshield screws onto the bottom of the detector (flame arrestor end). The rainshield helps protect the detector from rain and debris in the monitoring environment. Three color-coded leads extend from the top of the detector. The leads allow you to connect the detector to the amplifier. The output of the detector is non-linear and is linearized by the

amplifier (see below).

Amplifier

The amplifier converts the non-linear electrical output from the detector to a linear 4 to 20 mA signal that corresponds to the detection range and transmits the signal to a gas monitoring controller. The amplifier includes the terminal strips, gas select jumper strip, span pot, zero pot, load voltage pot, and test points (see Figure 1).

Controller Terminal Strip

The controller terminal strip is a three position plug-in style terminal strip located near the top of the amplifier. Use the controller terminal strip to wire the transmitter to a controller.

Detector Terminal Strip

The detector terminal strip is a three position plug-in style terminal strip located below the controller terminal strip. Use the detector terminal strip to connect the detector to the amplifier.

NOTE: The detector is factory-wired to the detector terminal strip. See “Wiring the PPM Hexane Transmitter” on page 5 for all wiring procedures related to the transmitter.

Gas Select Jumper Strip

The gas select jumper strip is a three position pin style terminal strip located in the lower left corner of the amplifier. A label next to the jumper strip indicates which pins must be shorted to select hexane or hydrogen. A jumper block is installed at the factory over pins 1 & 2 to select hexane as the gas type. The gas type defines the linearizing curve used by the amplifier to linearize the detector output.

Zero Pot

The zero pot is located in the upper left corner of the amplifier (see Figure 1). Use a small flat blade screwdriver to turn the zero pot’s adjustment screw and adjust the amplifier’s zero (fresh air) output during the start-up and calibration procedures.

Span Pot

The span pot is located to the right of the zero pot (see Figure 1). Use a small flat blade screwdriver to turn the span pot’s adjustment screw and adjust the amplifier’s gas response output during the calibration procedure.

Load Voltage Pot

The load voltage pot is located below the zero and span pots (see Figure 1). The load voltage pot is not needed for normal scheduled maintenance, so it is a right angle pot that is not accessible unless the amplifier is lifted out of the junction box enough to access the adjustment screw. Use a small flat blade screwdriver to turn the load voltage pot’s adjustment screw and adjust the amplifier’s detector load voltage when the detector or amplifier is replaced.

CAUTION: *The amplifier includes additional pots. They are factory-set. Do not adjust them.*

Test Points

The test points are in the lower left corner of the amplifier on either side of the gas select jumper strip (see Figure 1). The test points produce a 100 to 500 mV output that corresponds to the transmitter's 4 to 20 mA output. Use the test points and a voltmeter to measure the amplifier's output during the start-up and calibration procedures. The black test point on the left is the negative (-) test point and the red test point on the right is the positive (+) test point.

Junction Box

Use the junction box to install the transmitter at a mounting site that is remote from the controller. The junction box also protects the amplifier and wiring connections made to the amplifier. Use the top 3/4 inch conduit hub to connect wiring from the amplifier to the controller. Use the cover on the front of the junction box to access the interior of the junction box. The detector and amplifier are factory installed in the junction box.

Installation

This section describes procedures to mount the ppm hexane transmitter in the monitoring environment and wire the transmitter to a controller.

Mounting the PPM Hexane Transmitter

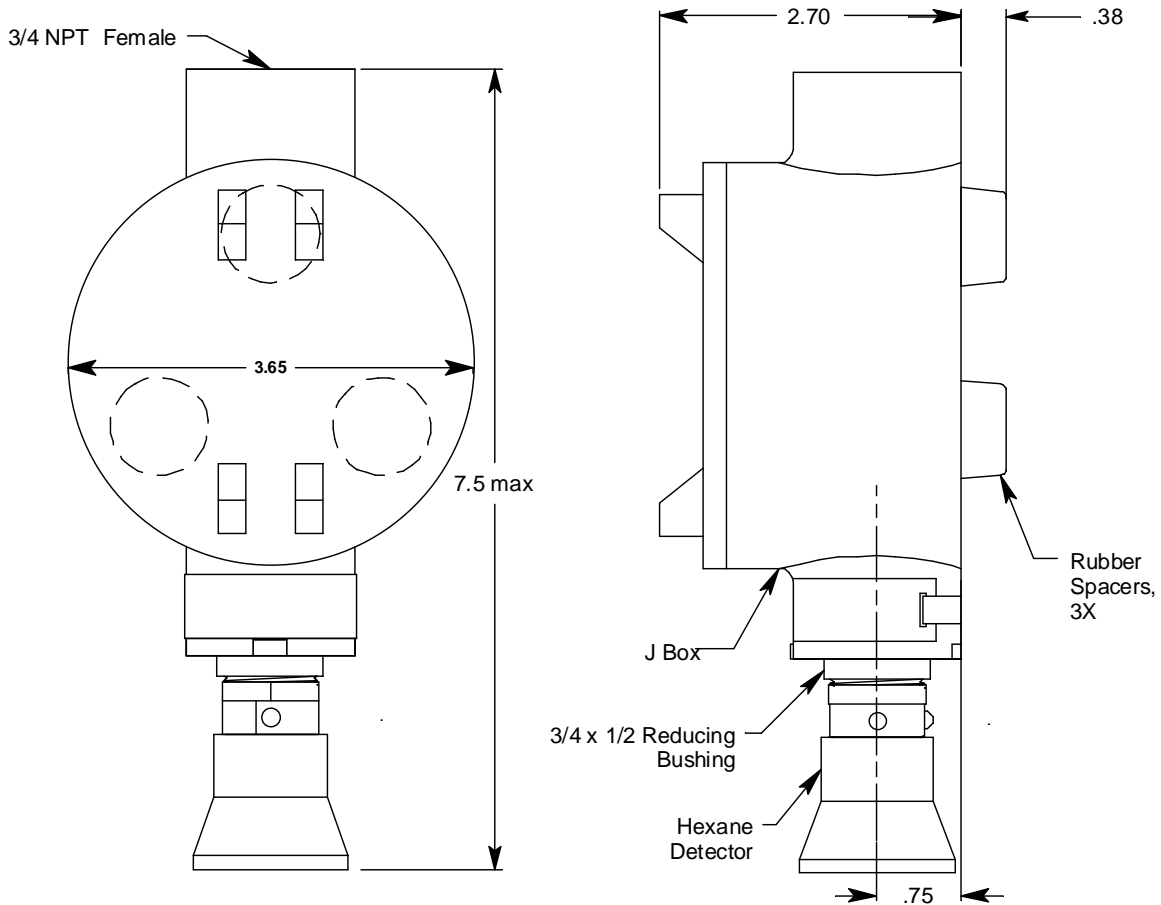

Figure 2: Mounting the PPM Hexane Transmitter

1. Select a mounting site that is representative of the monitoring environment. Consider the following when you select the mounting site.
 - Select a site where the transmitter is not likely to be bumped or disturbed. Make sure there is sufficient room to perform start-up, maintenance, and calibration procedures.
 - Select a site where the target gas is likely to be found first. For hexane, which is heavier than air, mount the transmitter near the floor or where hexane is most likely to accumulate.
2. At the monitoring site you select, hang or mount the junction box with the detector facing down (see Figure 2).

Wiring the PPM Hexane Transmitter

WARNING: *Always verify that the power to the controller is off before you make wiring connections.*

1. Turn off power to the controller.
2. Place the controller's power switch in the OFF position.
3. Remove the junction box cover.
4. The detector leads are factory wired. Verify that the detector leads are wired to the amplifier's detector terminal strip as shown in Figure 3.
5. To gain access to a plug-in terminal strip for wiring, pull it out of its socket by grasping the terminal strip and pulling. The detector strip is keyed so that the controller and detector terminal strips cannot be reversed inadvertently.
6. Guide a three-conductor, shielded cable or three wires in conduit through the top conduit hub of the junction box.
7. Pull out the controller terminal strip, and connect the three wires to the terminal strip as follows (see Figure 3).
 - Connect the positive wire to the **PWR/SIG "+"** terminal.
 - Connect the signal wire to the **PWR/SIG "S"** terminal.
 - Connect the negative wire to the **PWR/SIG "-"** terminal.

CAUTION: *If shielded cable is used, leave the cable shield's drain wire disconnected and insulated at the transmitter. You will connect the opposite end of the cable's drain wire to the controller's chassis (earth) ground.*

8. Reinstall the controller terminal strip into its socket.
9. Secure the junction box cover to the junction box.
10. Route the cable or wires leading from the ppm hexane transmitter through one of the conduit hubs at the controller housing.

CAUTION: *Do not route power and transmitter wiring through the same controller conduit hub. The power cable may disrupt the transmission of the transmitter signal to the controller.*

11. Connect the wires to the applicable detector/transmitter terminal strip at the controller as shown in Figure 3.

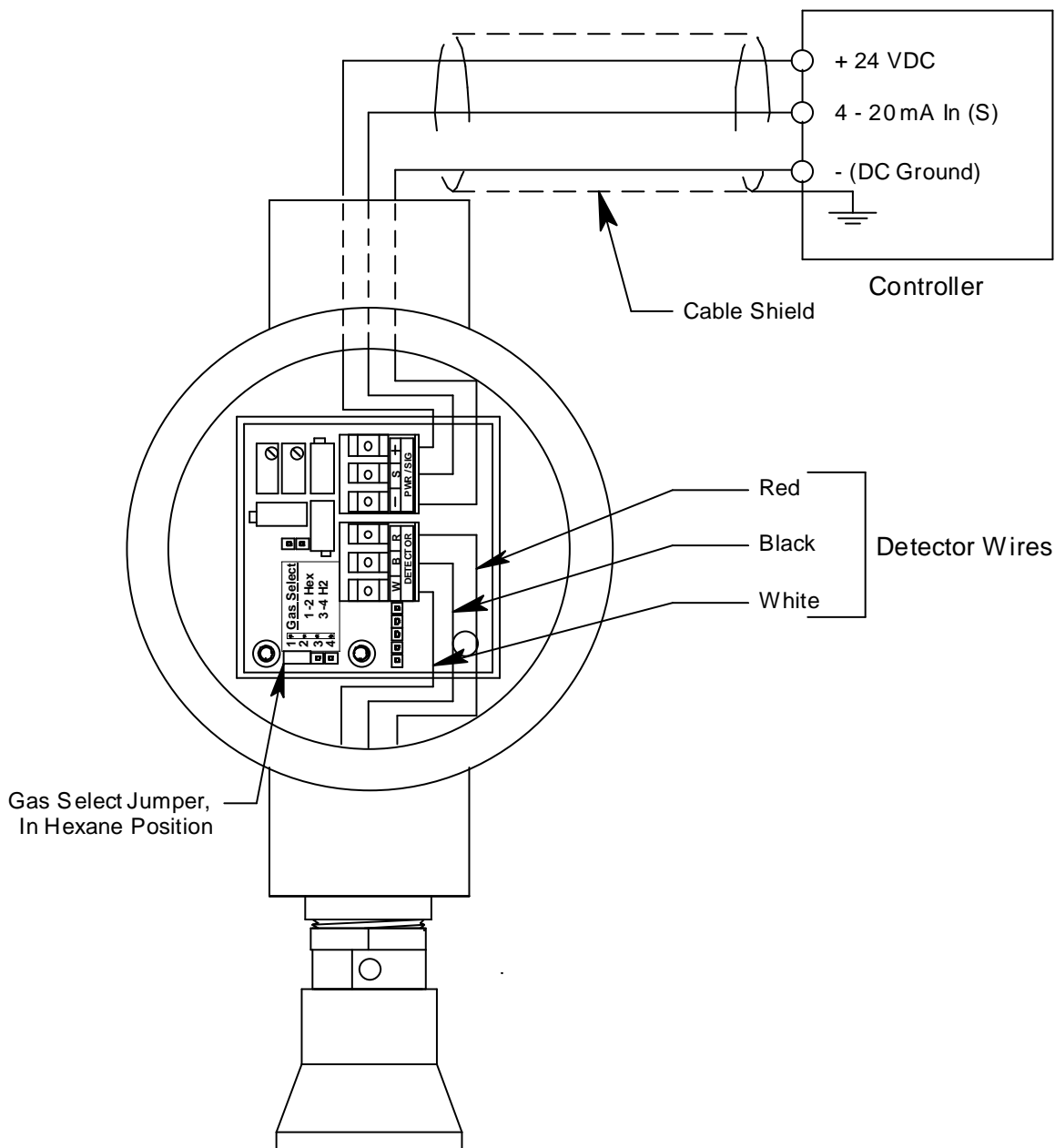

Figure 3: Wiring the PPM Hexane Transmitter to a Controller

12. If shielded cable is used, connect the cable's drain wire to an available chassis (earth) ground at the controller. RKI controllers typically have a ground stud that can be used to ground the cable's drain wire.

Start Up

This section describes procedures to start up the ppm hexane transmitter and place the transmitter into normal operation.

Introducing Incoming Power

1. Complete the installation procedures described earlier in this manual.
2. Verify that the power wiring to the controller is correct and secure. Refer to the controller operator's manual.

NOTE: When a transmitter is first powered up after installation or being off power for an extended period, its signal will increase rapidly over a few seconds to a high level and then the signal will decrease so that it appears stable after a few minutes. Be sure to make arrangements so that this does not cause unwanted alarms.

3. Turn on power to the controller.
4. Turn on the controller.
5. Verify that the controller is on and operating properly. Refer to the controller operator's manual.

Transmitter Burn-In Period

Once power has been applied to the transmitter, it will take several days for the transmitter signal to the controller to stabilize completely. This is the burn-in period. The zero reading may be slightly above zero after startup and will stabilize in about 5 to 7 days. The transmitter is calibrated at the factory before shipment and it is not necessary to calibrate the transmitter after startup. If calibration of the transmitter after startup is desired, wait at least 5 days after startup before calibrating the transmitter. A burn-in period of 7 days is recommended. See "Calibration" on page 15 for calibration instructions.

After the burn-in period, set the zero reading if necessary as described in "Calibration" on page 15.

CAUTION: *Do not adjust the zero or span potentiometers for at least 5 days after startup. If the fresh air reading is high enough to cause unwanted alarms during the burn-in period, adjust the zero pot only enough to bring the reading below the alarm point.*

Setting the Zero Signal

CAUTION: *If you suspect the presence of combustible gas in the monitoring environment, use the calibration kit and the zero air calibration cylinder to introduce "fresh air" to the detector and verify an accurate zero setting. See "Calibration" on page 15 for instructions to apply zero air when setting the zero signal.*

1. Verify that the transmitter is in a fresh air environment (environment known to be free of combustible gas).
2. Unscrew and remove the junction box cover from the junction box.
3. Set a voltmeter to measure in the millivolt (mV) range.

4. Plug the voltmeter leads into the test points on the amplifier. Plug the positive lead into the red + test point; plug the negative lead into the black - test point.
5. Verify a voltmeter reading of 100 mV (± 2 mV).
6. If necessary, use a small flat-blade screwdriver to adjust the zero pot until the voltmeter reading is 100 mV (± 2 mV).
7. Remove the voltmeter leads from the test points.
8. Secure the junction box cover to the junction box.

Maintenance

This section describes maintenance procedures. It includes preventive maintenance, troubleshooting, and component replacement procedures.

Preventive Maintenance

This section describes a preventive maintenance schedule to ensure the optimum performance of the ppm hexane transmitter. It includes daily, monthly, and quarterly procedures.

Daily

Verify a display reading of 0 ppm at the controller. Investigate significant changes in the display reading.

Monthly

This procedure describes a test to verify that the ppm hexane transmitter responds properly to the target gas.

WARNING: *The controller is not an active gas monitoring device during the response test procedure.*

NOTE: Performing a response test on the ppm hexane transmitter may cause alarms. Be sure to put the controller into its calibration mode or disable external alarms before performing this test.

NOTE: The following procedure assumes the use of a calibration kit which includes a calibration gas cylinder, a 0.5 LPM fixed flow regulator with an on/off knob, a calibration cup for the detector, and a humidifier tube to connect the regulator to the calibration cup.

Preparing for the response test

1. Place the controller into its calibration mode or disable external alarms.
2. Verify that the controller display reading for the channel you are testing is 0 ppm.
If the display reading is not 0 ppm, set the zero reading of the transmitter as described in "Start Up" on page 7, then continue this procedure.
3. Screw the calibration cup onto the bottom of the detector.
4. Use the humidifier tube to connect the regulator to the calibration cup.
5. Set a voltmeter to measure in the millivolt (mV) range.

6. Remove the junction box cover, then plug the voltmeter leads into the test points on the amplifier.

Plug the positive lead into the red + test point; plug the negative lead into the black - test point.

7. Use the following formula to determine the correct test points output for the test sample.

$$\text{Output (mV)} = (\text{calibrating sample/fullscale}) \times 400 + 100$$

For example, with a test sample of 250 ppm hexane and a fullscale setting of 500 ppm hexane, the correct output is 300 mV.

$$300 \text{ (mV)} = (250/500) \times 400 + 100$$

Performing the response test

1. Screw the regulator into the calibration cylinder.
2. Turn the regulator knob counterclockwise to open the regulator.
3. Allow the gas to flow for one minute.
4. Verify that the reading is within $\pm 20\%$ of the response reading you determined earlier.

NOTE: If the reading is not within $\pm 20\%$ of the correct response reading, calibrate the transmitter as described in “Calibration” on page 15 of this manual.

5. Turn the regulator knob clockwise to close the regulator.
6. Unscrew the regulator from the calibration cylinder.
7. Unscrew the calibration cup from the detector.

NOTE: For convenience, leave the regulator and calibration cup connected by the humidifier tube.

8. Remove the voltmeter leads from the amplifier test points.
9. Reinstall the junction box cover.
10. When the controller display reading falls below the alarm setpoints, return the controller to normal operation.
11. Store the components of the calibration kit in a safe place.

Biannual

Calibrate the ppm hexane transmitter as described in “Calibration” on page 15.

Troubleshooting

The troubleshooting guide describes symptoms, probable causes, and recommended action for problems you may encounter with the ppm hexane transmitter.

NOTE: This troubleshooting guide describes transmitter problems only. See the controller operator's manual for problems you may encounter with the controller.

Table 2: Troubleshooting the ppm Hexane Transmitter

Condition	Symptom(s)	Probable Causes	Recommended Action
Fail Condition	<ul style="list-style-type: none"> Controller indicates a fail condition. 	<ul style="list-style-type: none"> The transmitter wiring is disconnected or misconnected. The transmitter's zero reading is low enough to cause a fail condition. The transmitter is malfunctioning. 	<ol style="list-style-type: none"> Verify that the transmitter wiring is correct and secure. Calibrate the transmitter. If the fail condition continues, replace the detector. If the fail condition continues, contact RKI for further instruction.
Slow or No Response/ Difficult or Unable to Calibrate	<ul style="list-style-type: none"> Transmitter responds slowly or does not respond to response test. Unable to accurately set the zero or response reading during calibration. Transmitter requires frequent calibration. <p><i>Note: Under "normal" circumstances, the transmitter requires calibration once every 6 months. Some applications may require a more frequent calibration schedule.</i></p>	<ul style="list-style-type: none"> The calibration cylinder is low, out-dated, or defective. The calibration gas flow rate is too low. The transmitter is malfunctioning. 	<ol style="list-style-type: none"> Verify that the calibration cylinder contains an adequate supply of a fresh test sample. Verify that the regulator used for calibration is a 0.5 LPM regulator. If the calibration/response difficulties continue, replace the detector. If the calibration/response difficulties continue, contact RKI for further instruction.

Replacing Components of the PPM Hexane Transmitter

This section includes procedures to replace the ppm hexane detector and amplifier.

Replacing the PPM Hexane Detector

- Turn off power to the controller.
- Place the controller's on/off switch in the OFF position.
- Remove the junction box cover.
- Remove the detector terminal strip from its socket.
- Disconnect the detector leads from the detector terminal strip. Note the position of the color-coded leads as you remove them.
- Unscrew the detector from the junction box.
- Guide the detector leads of the replacement detector through the bottom conduit hub of the junction box, then screw the mounting threads of the detector into the conduit

hub.

8. Connect the detector leads to the detector terminal strip as shown in Table 3 below and Figure 3 on page 6 of this manual.

Table 3:Reconnecting the PPM Detector to the Amplifier

Detector Lead	Amplifier Detector Terminal Strip
Red	DETECTOR "R"
White	DETECTOR "W"
Black	DETECTOR "B"

9. Re-install the detector terminal strip into its socket.

NOTE: When a transmitter is first powered up with a new detector, its signal will increase rapidly over a few seconds to a high level and then the signal will decrease so that it appears stable after a few minutes. Be sure to make arrangements so that this does not cause unwanted alarms.

10. Turn on power to the controller.
11. Turn on the controller and place it into normal operation.
12. Allow the transmitter to run for 3 hours.
13. Make a preliminary setting of the sensor load voltage. See "Setting the Detector Load Voltage" on page 13. This will be a temporary load voltage setting since the load voltage will need to be set again after the burn-in period as described below.
14. Perform a preliminary calibration. See "Calibration" on page 15. This will be a temporary calibration since the new ppm detector must burn-in before it can be properly calibrated.
15. Allow the replacement detector to burn-in for at least 5 days before you continue with the next step. A burn-in period of 7 days is recommended.
16. After the burn-in period, set the load voltage as described in "Setting the Detector Load Voltage" on page 13.
17. After setting the load voltage, calibrate the transmitter as described in "Calibration" on page 15 of this manual.

Replacing the Amplifier

If you are replacing the amplifier, it is likely that the transmitter has been off power for an extended period. Make sure to follow the preliminary load voltage and preliminary calibration recommendations and the burn-in period recommendation before making the final load voltage setting and calibration.

1. Turn off power to the controller.
2. Place the controller's on/off switch in the OFF position.
3. Remove the junction box cover.
4. Unplug the detector terminal strip and controller terminal strip from their sockets. You may leave the wires connected to the terminal strips.
5. Unscrew and remove the screw with the flat and lock washers that secures the

amplifier to the junction box.

6. Remove the old amplifier.
7. Install the detector and controller terminals strips into their sockets on the new amplifier as shown in Figure 3 on page 6 of this manual. If controller leads or detector leads were removed during this procedure, refer to Tables 4 and 5 below.

Table 4:Reconnecting the PPM Hexane Amplifier to the Controller

Amplifier Controller Terminal Strip	Controller Transmitter Terminal Strip (typical)
PWR/SIG “-”	- (DC -)
PWR/SIG “S”	S (4 - 20 mA In)
PWR/SIG “+”	+ 24V

Table 5:Reconnecting the PPM Hexane Detector to the Amplifier

Amplifier Detector Terminal Strip	Detector Lead
DETECTOR “R”	RED
DETECTOR “W”	WHT
DETECTOR “B”	BLK

8. Lay the new amplifier in the junction box. Do not re-install the amplifier in the junction box with the screw, flat washer, and lock washer yet because you will need to pull it out for access to the load voltage adjust pot below.

NOTE: When a transmitter is first powered up with a new amplifier, the initial output may be either high or below zero. Be sure to make arrangements so that this does not cause unwanted alarms.

9. Turn on power to the controller.
10. Turn on the controller and place it into normal operation.
11. Allow the transmitter to run for 3 hours.
12. Make a preliminary setting of the sensor load voltage. See “Setting the Detector Load Voltage” on page 13. This will be a temporary load voltage setting since the load voltage will need to be set again after the burn-in period as described below.
13. Install the amplifier into the junction box with the screw, lock washer, and flat washer you removed in Step 5 above. A foam gasket that orients the amplifier and keeps it from rotating is installed on the bottom of the amplifier. Make sure the amplifier is seated flat in the junction box.
14. Perform a preliminary calibration. See “Calibration” on page 15. This will be a temporary calibration since the new ppm detector must burn-in before it can be properly calibrated.

15. Allow the replacement detector to burn-in for at least 5 days before you continue with the next step. A burn-in period of 7 days is recommended.
16. After the burn-in period, set the load voltage as described in “Setting the Detector Load Voltage” on page 13.
17. After setting the load voltage, calibrate the transmitter as described in “Calibration” on page 15 of this manual.

Setting the Detector Load Voltage

The detector load voltage must be reset when the detector or amplifier is replaced or if you suspect that it has been changed from the factory setting for your detection range. This procedure involves setting a voltage while applying calibration gas to the detector that matches the full-scale concentration for the transmitter. After replacing the detector or amplifier as described earlier in this manual, the following procedure must be completed before calibrating the sensor. Be sure to follow the timing recommendations in “Replacing the PPM Hexane Detector” on page 10 and “Replacing the Amplifier” on page 11 for setting the load voltage.

WARNING: The controller is not an active gas monitoring device during the load voltage setting procedure.

NOTE: The following procedure assumes the use of a calibration kit which includes a calibration gas cylinder equal to the transmitter’s full scale gas concentration, a 0.5 LPM fixed flow regulator with an on/off knob, a calibration cup for the detector, and a humidifier tube to connect the regulator to the calibration cup.

1. Screw the calibration cup onto the bottom of the hexane detector.
2. Use the humidifier tube to connect the regulator to the calibration cup.
3. Set a voltmeter to measure in the DC volt range.
4. Remove the junction box cover.
5. Remove the screw, flat washer, and lock washer retaining the amplifier to the junction box, and carefully lift the amplifier to gain access to the load voltage adjustment pot. See Figure 1 for the pot location.
6. Screw the regulator into the calibration gas cylinder. The cylinder must be equal to the transmitter’s full scale gas concentration.
7. Turn the regulator knob counterclockwise to open the regulator.
8. Allow the calibration gas to flow for one minute.

- Measure the voltage between the B terminal on the detector terminal strip and the - (negative) terminal on the controller terminal strip as shown below in Figure 4.

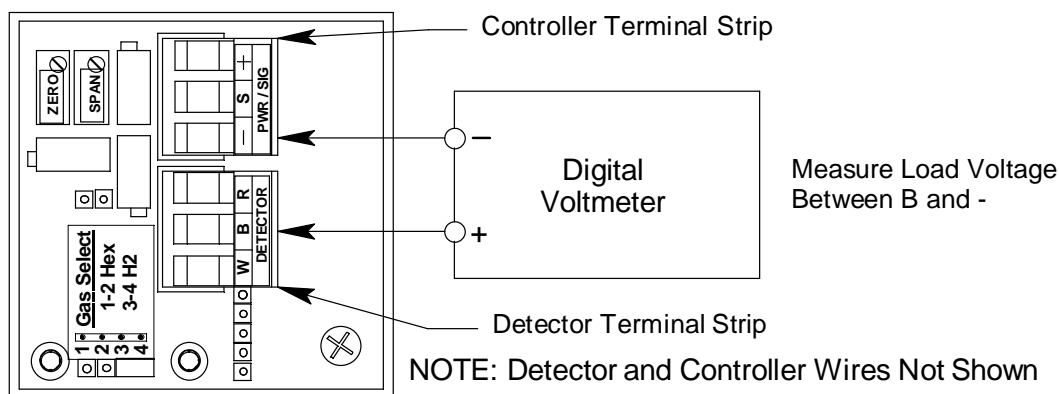

Figure 4: Load Voltage Measurement

- Adjust the load voltage adjust pot until the load voltage is $4.0\text{ V} \pm 0.1\text{ V}$.
- Turn the regulator knob clockwise to close the regulator.
- Unscrew the regulator from the calibration cylinder.
- Unscrew the calibration cup from the detector.

NOTE: For convenience, leave the regulator and calibration cup connected by the humidifier tube.

- Re-install the amplifier to the housing using the screw, flat washer, and lock washer removed in Step 5 above.
- Calibrate the ppm hexane transmitter as described in "Calibration" on page 15.
- Verify that the controller display reading decreases and stabilizes at 0 ppm.
- Store the components of the calibration kit in a safe and convenient place.

Calibration Frequency

Although there is no particular calibration frequency that is correct for all ppm hexane transmitter applications, a calibration frequency of every 6 to 12 months is adequate for most applications. Unless experience in a particular application dictates otherwise, RKI Instruments, Inc. recommends a calibration frequency of every 6 months.

If an application is not very demanding, for example detection in a clean, temperature controlled environment where hexane is not normally present, and calibration adjustments are minimal at calibration, then a calibration frequency of every 12 months is adequate.

If an application is very demanding, for example if hexane is present often and in significant concentrations or the environment is not well controlled, then more frequent calibration than every 6 months may be necessary.

Calibration

This section describes how to calibrate the ppm hexane transmitter. It includes procedures to prepare for calibration, set the zero reading, set the response reading, and return to normal operation.

WARNING: *The controller is not an active gas monitoring device during the calibration procedure.*

NOTE: The following procedure assumes the use of a calibration kit which includes a calibration gas cylinder, a 0.5 LPM fixed flow regulator with an on/off knob, a calibration cup for the detector, and a humidifier tube to connect the regulator to the calibration cup.

Calibration Kit Humidifier Tube

The ppm hexane detector requires normal atmospheric humidity levels to respond properly to hexane. Normal atmospheric humidity variations do not affect the detector's response to hexane in ambient air, but the ultra low humidity level of gas from a calibration cylinder requires that the calibration sample be humidified for the detector to respond properly. The calibration kit for the ppm hexane transmitter includes a humidifier tube that is not normally included in other calibration kits. This humidifier tube humidifies the calibration sample flowing through it by absorbing humidity from the ambient air and adding it to the sample. The humidifier tube is included in the "Parts List" on page 17.

WARNING: *A humidifier tube must be used when calibrating the ppm hexane transmitter test for the detector to respond properly to the calibration gas. Failure to use a humidifier tube will result in an inaccurate calibration.*

Preparing for Calibration

1. Screw the calibration cup onto the bottom of the hexane detector.
2. Use the humidifier tube to connect the regulator to the calibration cup.
3. Set a voltmeter to measure in the millivolt (mV) range.
4. Remove the junction box cover, then plug the voltmeter leads into the test points on the amplifier.

Plug the positive lead into the red + test point; plug the negative lead into the black - test point.

5. Use the following formula to determine the correct test points output for the calibrating sample.

$$\text{Output (mV)} = (\text{calibrating sample}/\text{fullscale}) \times 400 + 100$$

For example, with a calibrating sample of 250 ppm hexane and a fullscale setting of 500 ppm hexane, the correct output is 300 mV.

$$300(\text{mV}) = (250/500) \times 400 + 100$$

6. Place the controller into its calibration mode or disable external alarms.

NOTE: Calibrating the ppm hexane transmitter may cause alarms. Be sure to put the controller into its calibration program or disable external alarms before continuing.

Setting the Zero Reading

NOTE: If you can verify that the ppm hexane transmitter is in a fresh air environment, you do not need to apply zero air to the detector before adjusting the zero reading.

1. Screw the regulator into the zero air calibration cylinder.
2. Turn the regulator knob counterclockwise to open the regulator.
3. Allow the gas to flow for one minute and verify a reading of 100 mV (± 2 mV). If necessary, use the zero pot on the amplifier to adjust the reading to 100 mV (± 2 mV).
4. Turn the regulator knob clockwise to close the regulator.
5. Unscrew the regulator from the zero air calibration cylinder. Leave the sample humidifier tube connected to the regulator and the calibration cup.

Setting the Response Reading

1. Screw the regulator into the calibration cylinder. Verify that the calibration gas is representative of the transmitter's target gas.
2. Turn the regulator knob counterclockwise to open the regulator.
3. Allow the calibration gas to flow for one minute and verify that the reading matches the response reading (± 2 mV) you determined earlier. If necessary, use the span pot on the amplifier to adjust the reading to match the correct response reading.
4. Turn the regulator knob clockwise to close the regulator.
5. Unscrew the regulator from the calibration cylinder.

Returning to Normal Operation

1. Remove the voltmeter leads from the amplifier test points.
2. Unscrew the calibration cup from the detector

NOTE: For convenience, leave the regulator and calibration cup connected by the humidifier tube.

3. Secure the junction box cover to the junction box.
4. When the controller display reading falls below the alarm setpoints, return the controller to normal operation.
5. Verify that the controller display reading decreases and stabilizes at 0 ppm.
6. Store the components of the calibration kit in a safe and convenient place.

Parts List

Table 6 lists replacement parts and accessories for the ppm hexane transmitter.

Table 6:Parts List

Part Number	Description
18-0400RK	Junction box with cover; (pre-drilled for amplifier)
33-2001RK-01	Humidifier tube w/3/16" tubing on ends, for calibration kit
57-1056RK-XX	Amplifier (specify target gas and detection range)
65-2461RK	PPM hexane transmitter, 0 - 500 ppm
71-0144RK	<i>65-2461RK PPM Hexane Transmitter Operator's Manual</i> (this document)
81-0083RK-21	Steel calibration cylinder, 500 ppm hexane in air, 34 liter
81-0083RK-23	Steel calibration cylinder, 500 ppm hexane in air, 103 liter
81-0076RK-01	Zero air calibration cylinder, 34 liter
81-0076RK-03	Steel calibration cylinder, zero air, 103-liter
81-1050RK	Regulator, 0.5 liter/minute; with pressure gauge and flow control knob, for 17 liter and 34 liter steel calibration cylinders
81-1051RK	Regulator, 0.5 liter/minute; with pressure gauge and flow control knob, for 34 liter aluminum and 58 liter and 103 liter steel calibration cylinders
81-1117RK	Calibration cup
81-F026RK	Calibration kit, includes regulator, humidifier tube, calibration cup, and 103 liter 500 ppm hexane steel calibration cylinder
81-F026RK-LV	Calibration kit, includes regulator, humidifier tube, calibration cup, and 34 liter 500 ppm hexane steel calibration cylinder
SG-8547-01	PPM hexane detector