

Model 1017-06S8 Combustible Gas Sample Draw Detector Head Operator's Manual

Part Number: 71-0373

Revision: P1

Released: 6/10/15

WARNING

Read and understand this instruction manual before operating instrument. Improper use of the gas monitor could result in bodily harm or death.

Periodic calibration and maintenance of the gas monitor is essential for proper operation and correct readings. Please calibrate and maintain this instrument regularly! Frequency of calibration depends upon the type of use you have and the sensor types. Typical calibration frequencies for most applications are between 3 and 6 months, but can be required more often or less often based on your usage.

Warranty

RKI Instruments, Inc. warrants gas alarm equipment manufactured by RKI and sold by RKI to be free from defects in materials and workmanship for a period of one year from date of shipment from RKI Instruments, Inc. Any parts found defective within that period will be repaired or replaced, at our option, free of charge. This warranty does not apply to items that are subject to deterioration or consumption in normal service, and which must be cleaned, repaired, or replaced routinely. Those items include, but are not limited to:

absorbent cartridges	sensors
pump diaphragms and valves	filter elements
lamp bulbs and fuses	batteries

This warranty is voided by mechanical damage, misuse, alteration, rough handling, or repairs not in accordance with the operator's manual. This warranty indicates the full extent of our liability. We are not responsible for removal or replacement costs, local repair costs, transportation costs, or contingent expenses incurred without our prior approval.

THIS WARRANTY IS IN LIEU OF ANY OTHER WARRANTIES AND REPRESENTATIONS, EXPRESSED OR IMPLIED, AND ALL OTHER OBLIGATIONS OR LIABILITIES ON THE PART OF RKI INSTRUMENTS, INC. INCLUDING BUT NOT LIMITED TO THE WARRANTY OF MERCHANTABILITY OR FITNESS FOR A PARTICULAR PURPOSE. IN NO EVENT SHALL RKI INSTRUMENTS, INC. BE LIABLE FOR INDIRECT, INCIDENTAL, OR CONSEQUENTIAL LOSS OR DAMAGE OF ANY KIND CONNECTED WITH THE USE OF ITS PRODUCTS OR FAILURE OF ITS PRODUCTS TO FUNCTION OR OPERATE PROPERLY.

This warranty covers instruments and parts sold to end users by authorized distributors, dealers, and representatives of RKI Instruments, Inc.

We do not assume indemnification for any accident or damage caused by the operation of this gas monitor. Our warranty is limited to replacement of parts or our complete goods.

Table of Contents

Overview	1
Specifications	1
Description	2
Housing	2
Subpanel Assembly	3
Installation	4
Connecting the Sample Lines to the Model 1017-06S8	5
Wiring the Model 1017-06S8	5
Startup	7
Introducing Incoming Power	7
Setting the Zero Reading	7
Maintenance	8
Preventive Maintenance	8
Troubleshooting	8
Replacing Components of the Model 1017-06S8	9
Calibration	10
Preparing for Calibration	10
Setting the Zero Reading	10
Setting the Response Reading	10
Returning to Normal Operation	11
Parts List	11

Sample-Draw Combustible Gas Detection

Overview

This manual describes the Model 1017-06S8 sample draw combustible gas detector. This manual also describes how to install, start up, maintain, and calibrate the Model 1017-06S8. A parts list at the end of this manual lists replacement parts and accessories.

Specifications

Table 1 lists specifications for the Model 1017-06S8.

Table 1: Specifications

Target Gas	Combustible gas, isobutane calibration standard
Input Power	24 VDC
Construction (housing)	Cast Aluminum Alloy, Explosion Proof for Class I, Groups B, C, & D
Dimensions	7.00 in. H x 7.00 in. W x 6.13 in. D
Sampling Method	Sample-draw
Recommended Sample Flow	2.0 SCFH
Detection Range	0 to 100% LEL
Response Time	90% in 30 seconds
Accuracy	±5% of reading or ± 2% LEL (whichever is greater)

WARNING: *When using the Model 1017-06S8, you must follow the instructions and warnings in this manual to assure proper and safe operation of the Model 1017-06S8 and to minimize the risk of personal injury. Be sure to maintain and periodically calibrate the Model 1017-06S8 as described in this manual.*

Description

This section describes the components of the Model 1017-06S8. The Model 1017-06S8 consists of the housing and subpanel assembly.

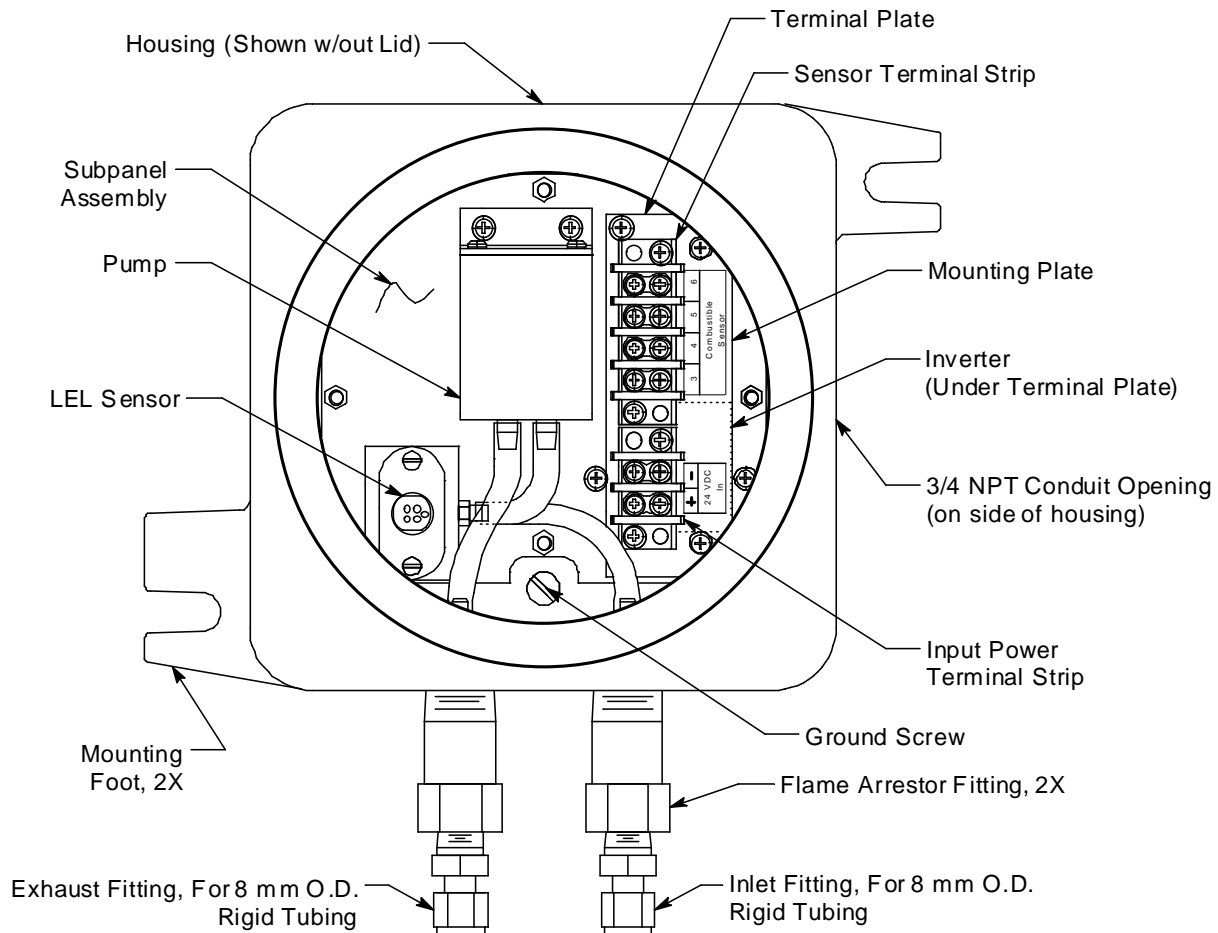

Figure 1: Model 1017-06S8 Component Location

Housing

The Model 1017-06S8's cast aluminum alloy housing is rated as explosion proof for Class I Groups B, C, & D.

The housing has a screw-on cover on the front which may be removed for access to the internal components. It also has two integral mounting feet, one on the upper right corner and one on the lower left corner, for use with 3/8" mounting bolts or screws.

The inlet and exhaust fittings are installed on the bottom of the housing. A 3/4" NPT conduit opening is on the right side of the housing to allow for wire entry. The subpanel assembly is mounted to the interior of the housing.

Inlet & Exhaust Fittings

The inlet and exhaust fittings on the bottom of the housing allow the gas sample to enter and exit the Model 1017-06S8. They are made of stainless steel. The inlet fitting is on the right and the exhaust fitting is on the left. The fittings accept 8 mm O.D. rigid metal tubing. See the Installation section on page 4 to connect tubing to the inlet and exhaust fittings. Figure 2 below illustrates the flow path of the sample inside the Model 1017-06S8.

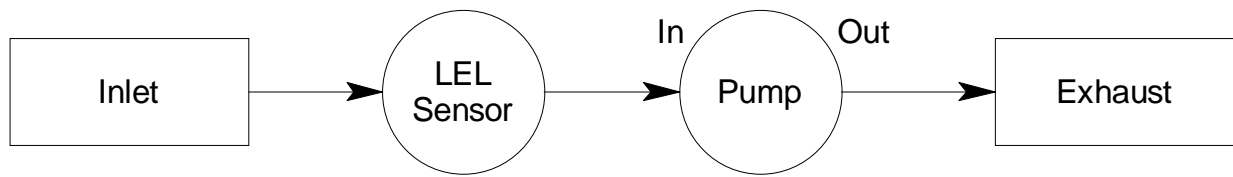

Figure 2: Model 1017-06S8 Flow Diagram

Subpanel Assembly

All the internal components of the Model 1017-06S8 are part of the subpanel assembly. It is mounted to the inside of the housing. The subpanel assembly consists of an aluminum subpanel with the following components mounted on it: the terminal plate, the inverter, the pump, the sensor block, and the combustible sensor (see Figure 1).

Terminal Plate

The terminal plate is mounted on the right side of the subpanel. Two terminal strips for external wiring are located on it. The sensor terminal strip is at the top of the plate. It is a four point terminal strip used to connect the sensor to an external controller. The power input terminal strip is a two point terminal strip located below the sensor terminal strip. It is used to connect 24 VDC to the Model 1017-06S8.

Inverter

The inverter is located on the subpanel below the terminal plate. It is held in place by the terminal plate and is prevented from sliding out by screws which are screwed into the subpanel. A foam pad installed on the subpanel below the inverter helps keep the inverter in place.

The inverter takes the 24 VDC from the power input terminal strip and converts it to 24 VAC for use by the pump.

Pump

The pump is mounted to a bracket on the subpanel to the left side of the sensor terminal strip. It draws the gas sample into the Model 1017-06S8 through the inlet fitting and exhausts it through the exhaust fitting. The pump operates on 24 VAC which is generated by the inverter.

Sensor Block & Combustible Sensor

The sensor block is mounted to the subpanel below and to the left of the pump. It is made of aluminum. It provides a chamber for sample to flow over the combustible sensor. The sensor is pushed into the sensor block and an o-ring seal in the block seals the chamber. The sensor is held in the sensor block by a retaining plate. Two captive panel screws hold the retaining plate on the sensor.

The sensor is an HW-6211 combustible gas sensor. It is a catalytic combustion sensor and consists of two sensing elements enclosed in a stainless steel body. A porous stainless steel flame arrestor allows sample to diffuse into the sensor. Five pins extend out the rear of the sensor. These pins mate to a five position socket that is wired to the sensor terminal strip.

Installation

This section describes procedures to mount the Model 1017-06S8 in the monitoring environment and wire it to a controller.

1. Select the mounting site. Consider the following when you select the mounting site.
 - Is there enough room to remove the cover and make wiring connections at the right side of the housing and tubing connections at the bottom of the housing?
 - Is there is sufficient room to perform start-up, maintenance, and calibration procedures?

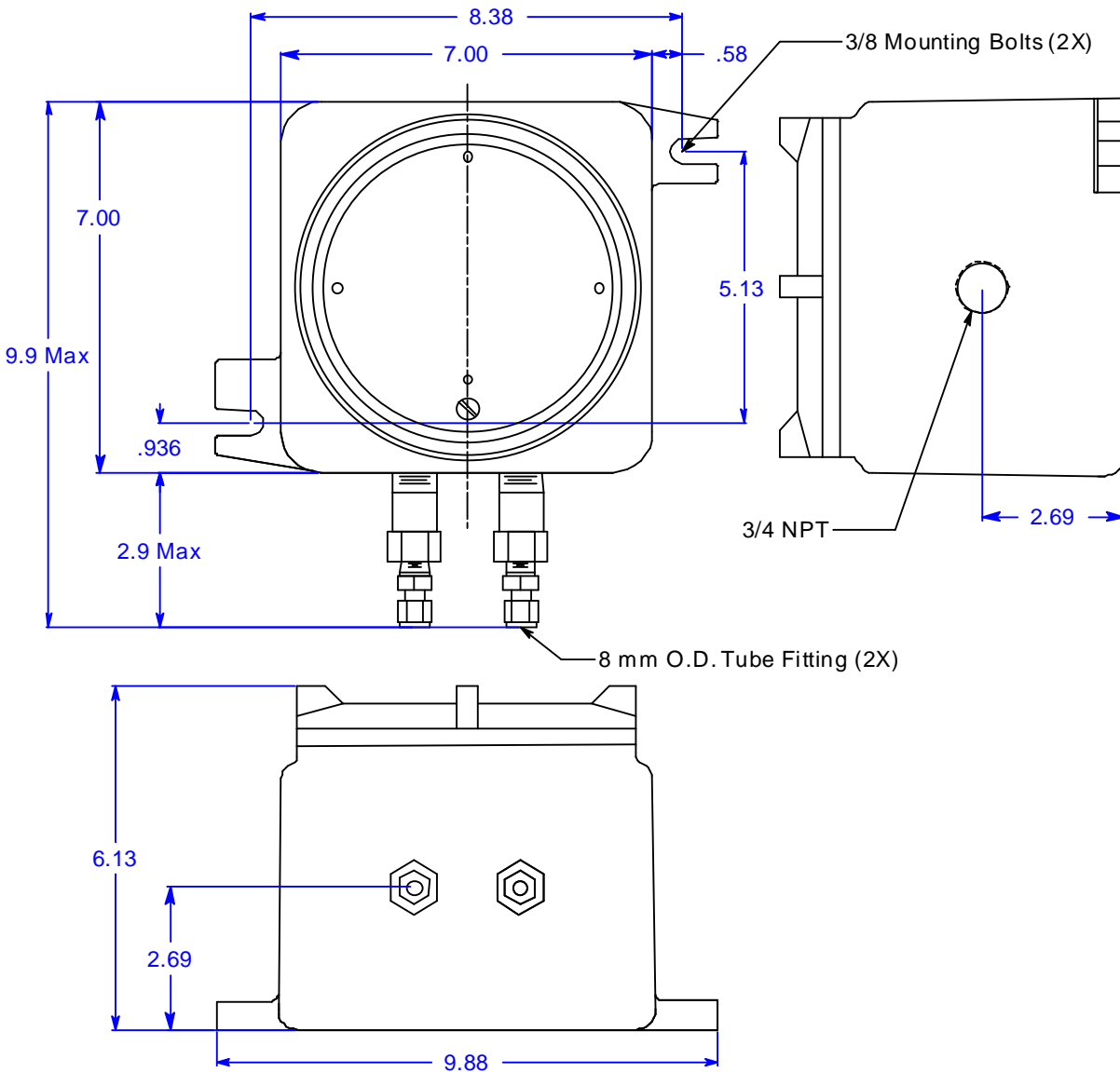

Figure 3: Mounting the Model 1017-06S8

4. Position the Model 1017-06S8 on a vertical surface.
5. Insert 3/8 inch screws or bolts through the slots in the two mounting feet to secure the housing to the mounting surface.

Connecting the Sample Lines to the Model 1017-06S8

1. Attach 8 mm O.D. rigid sample tubing to the INLET fitting.

CAUTION: *If you use **flexible** sample tubing (vinyl or polyurethane for example), use an appropriate metal insert to seal the connection between the tubing and the INLET fitting. See the Parts List for an example of an appropriate metal insert.*

2. Place the opposite end of the tubing at the sampling area.

CAUTION: *Avoid loops or slumps in the incoming sample line. To reduce response time, keep the incoming sample line as short as possible.*

3. Install an appropriate line filter and flowmeter in a convenient location on the inlet line. The 33-3050RK line filter with flow indicator is recommended for verifying there is sufficient flow.
4. Install an appropriate valve before the flowmeter to allow adjustment of the sample flow to 2.0 SCFH (a flowmeter with a built in valve may also be used).
5. Attach 8 mm O.D. rigid sample tubing to the EXHAUST fitting.
6. Route the opposite end of the tubing to an open area where the sample can safely disperse.

Wiring the Model 1017-06S8

WARNING: *Always verify that power is off before making or changing any wiring connections.*

1. Verify that all power is off.
2. Unscrew the cover from the housing.
3. Guide a six-conductor, shielded cable, or six wires in conduit through the conduit opening on the right side of the housing. Use appropriate conduit fittings and construction technique for the environmental rating and hazardous location classification of the housing. The housing is rated NEMA 4 and classified explosion proof for Class I, Groups B, C, and D.
4. Connect two wires to the input power terminal strips as shown in Figure 4.
5. Route the two wires back to the 24 VDC power source.
6. Connect the detector leads to the sensor terminal strip in the housing.

CAUTION: *If shielded cable is used, leave the shield drain wire insulated and disconnected at the detector. You will connect the opposite end of the cable's drain wire at the controller.*

7. Secure the cover to the housing.
8. Route the cable or wires leading from the Model 1017-06S8's sensor terminal strip through one of the conduit hubs at the controller housing. Use appropriate conduit fittings and construction technique for the environmental rating of the controller. RKI controllers are typically rated NEMA 4X.

CAUTION: Do not route controller power and detector wiring through the same conduit hub.
The power cable may disrupt the transmission of the detector signal to the controller.

9. Connect the detector wires to the applicable controller terminal strip. See the controller operator's manual and the controller's detector head specification sheet for the Model 1017-06S8.
10. If using shielded cable, connect the cable's drain wire to an available chassis ground at the controller. RKI controllers typically have a ground stud that is a convenient grounding location.

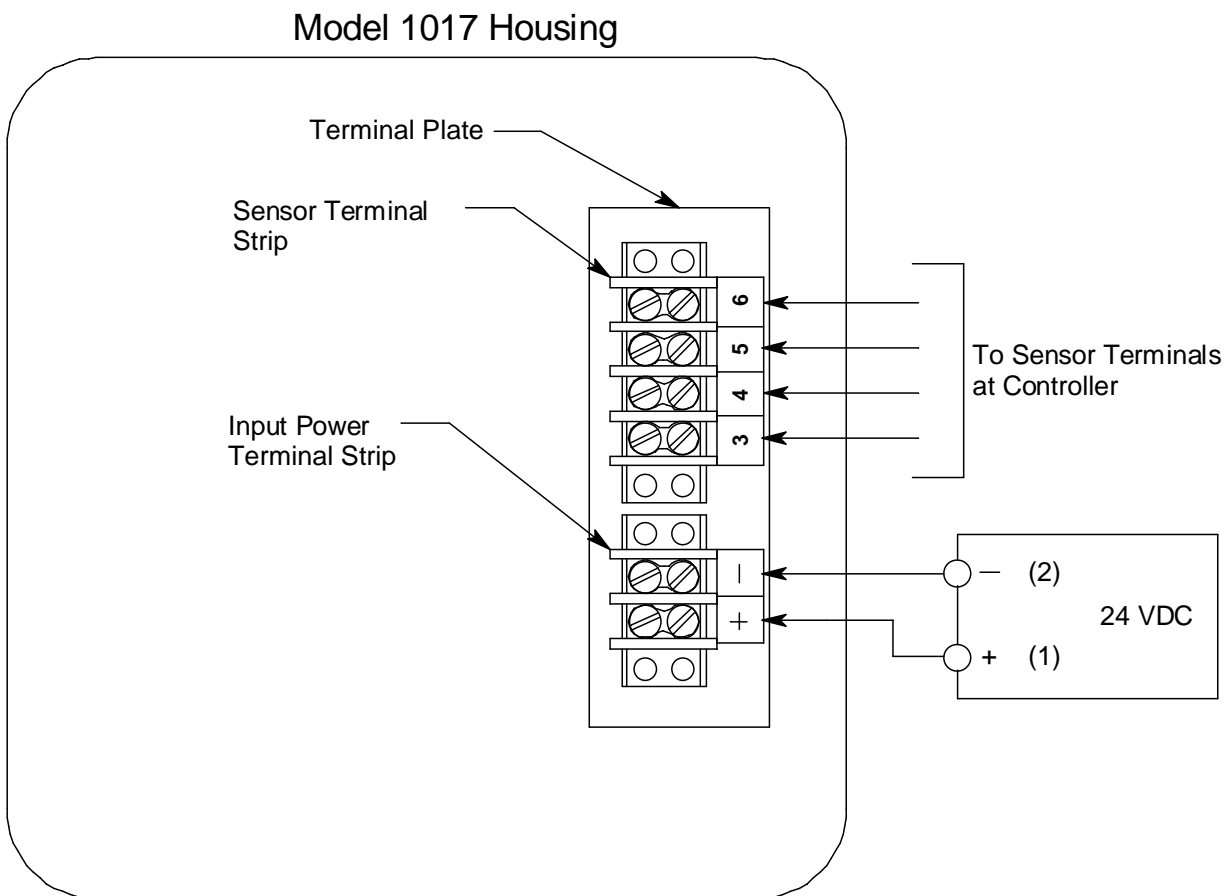

Figure 4: Wiring the Model 1017-06S8

Start Up

This section describes procedures to start up the Model 1017-06S8 and place it into normal operation.

Introducing Incoming Power

1. Complete the installation procedures described earlier in this manual.
2. Verify that the sensor and power wiring are correct and secure.
3. Turn on or plug in the incoming power at the power source end.
4. Verify that the flow rate is 2.0 SCFH with a flowmeter. If necessary, adjust the flow with the valve that was installed.
5. Verify that the recommended flow indicator is indicating flow.
6. Allow the sensor in the Model 1017-06S8 to warm-up for 5 minutes before continuing.

Setting the Zero Reading

CAUTION: *If you suspect the presence of combustible gas in the monitoring environment, use a zero air calibration cylinder to introduce “fresh air” to the sensor and verify an accurate zero setting.*

1. Verify that the Model 1017-06S8 is sampling a fresh air environment (environment known to be free of combustible gas).
2. Verify a reading of 0% LEL at the controller.

If the display reading is 0% LEL, start up is complete. The Model 1017-06S8 is in normal operation. If the display reading is not 0, continue with step 3.

CAUTION: *Normally the Model 1017-06S8 is tested and calibrated with a controller and delivered with a controller. If your Model 1017-06S8 was not calibrated with the controller at the factory because you are replacing or adding a detector head, perform a complete calibration. See the Calibration section for calibration instructions.*

3. See the controller instruction manual for instructions on setting the zero reading at the controller.

Maintenance

This section describes maintenance procedures. It includes preventive maintenance procedures. This section also includes procedures to troubleshoot the Model 1017-06S8 and replace components.

Preventive Maintenance

This section describes a preventive maintenance schedule to ensure the optimum performance of the Model 1017-06S8. It includes daily and quarterly procedures.

Daily

1. Verify that the recommended flow indicator is indicating flow.
2. Verify a display reading of 0%LEL at the controller. Investigate significant changes in the display reading.

Quarterly

Calibrate the Model 1017-06S8 as described in the “Calibration” section on page 10.

Troubleshooting

The troubleshooting guide describes symptoms, probable causes, and recommended action for problems you may encounter with the Model 1017-06S8.

NOTE: This troubleshooting guide describes Model 1017-06S8 problems only. See the controller instruction manual for controller troubleshooting recommendations.

Fail Condition

Symptoms

- The controller is indicating a fail condition.

Probable causes

- The detector wiring is disconnected or misconnected.

Recommended action

1. Verify that the detector wiring is correct and secure. The Installation section on page 4 describes detector wiring connections.
2. Calibrate the Model 1017-06S8 as described in the Calibration section on page 10.
3. If the fail condition continues, replace the sensor as described later in this section.
4. If the fail condition continues, contact RKI Instruments, Inc. for further instruction.

Slow or No Response/Difficult or Unable to Calibrate

Symptoms

- The detector responds slowly or does not respond during a response test.
- Unable to accurately set the zero or response reading at the controller during the calibration procedure.
- The detector requires frequent calibration.

NOTE: Under “normal” circumstances, the detector requires calibration once every three months. Some applications may require a more frequent calibration schedule.

Probable causes

- The calibration cylinder is low, out-dated, or defective.
- The Model 1017-06S8's flow rate is too low because of an obstructed sample line, failed pump, etc.
- The Model 1017-06S8's inverter is malfunctioning causing a low flow rate.

Recommended action

1. Verify that the calibration cylinder contains an adequate supply of a fresh test sample.
2. If necessary, set the correct flow rate.
3. If you cannot set the correct flow rate, check the sample line for obstructions or kinks.
4. If the flow cannot be set properly, contact RKI Instruments, Inc. for further instruction.
5. If the flow can be set and the calibration/response difficulties continue, replace the sensor as described later in this section.
6. If the calibration/response difficulties continue, contact RKI Instruments, Inc. for further instruction.

Replacing Components of the Model 1017-06S8

This section includes procedures to replace the sensor and sample fitting ferrules.

Replacing the Combustible Gas Sensor

1. Turn off the 24 VDC power supply and the controller power.
2. Unscrew the housing cover.
3. Unscrew the two captive panel screws that secure the retaining plate until they come out of the standoffs, then lift the plate with screws, connector, and sensor out of the sensor block.
4. Unplug the connector from the sensor.
5. Verify that you are using the correct replacement sensor, then plug the sensor into the connector.
6. Place the sensor in the sensor block, then position the retaining plate on the two standoffs.
7. Secure the retaining plate to the standoffs with the two panel screws.
8. Turn the 24 VDC power supply on and turn on the controller.

CAUTION: *Allow the replacement sensor to warm up for 15 minutes before you continue.*

9. Calibrate the replacement sensor as described in the "Calibration" section on page 10.

Replacing the Sample Fitting Ferrules

The inlet and exhaust fittings each include two ferrules that seal the incoming or exhaust tubing to the fitting. Replace the ferrules if the seal is bad or if you replace the sample tubing. Always replace the ferrules as a pair.

1. Disconnect the sample tubing from the fitting, then unscrew the nut from the fitting.
2. Verify that the ferrules did not remain in the nut. If necessary, remove the ferrules from the nut.
3. Position the nut so the threaded end is facing you, then insert the bottom (smaller) ferrule into the nut. Insert the ferrule so the flat side is facing down.

NOTE: Make sure the bottom ferrule is laying flat in the nut.

4. Insert the cone-shaped front ferrule on top of the bottom ferrule. Insert the ferrule so the smaller end of the cone is facing up.
5. Screw the nut onto the fitting, then connect the sample tubing to the fitting. Make sure you firmly tighten the tubing to the fitting.

Calibration

This section describes how to calibrate the Model 1017-06S8. It includes procedures to prepare for calibration, set the zero reading, set the response reading, and return to normal operation.

The standard calibration gas for the Model 1017-06S8 is isobutane.

NOTE: Calibrating the Model 1017-06S8 may cause alarms. Be sure to put the controller into its calibration program or disable external alarms before continuing.

NOTE: This procedure describes calibration using a demand flow regulator.

Preparing for Calibration

1. Follow the instructions in the controller's operator's manual for entering calibration mode.
2. Screw the regulator into a zero air calibration cylinder.

NOTE: If you can verify that the Model 1017-06S8 is in a fresh air environment, you do not need to apply zero air to the detector before setting the zero reading.

Setting the Zero Reading

1. Connect the sample tubing from the demand flow regulator to the Model 1017-06S8's inlet line. **This step is not necessary if you verified a fresh air environment earlier in this procedure.**
2. Allow the Model 1017-06S8 to draw sample for one minute.
3. Follow the directions in the controller's operator's manual for setting the zero reading. If you used a zero air calibration cylinder to set the zero reading, proceed to step 4. If you verified a fresh air environment, proceed to the next section, Setting the Response Reading.
4. Disconnect the sample tubing from the inlet line.
5. Unscrew the regulator from the zero air calibration cylinder.

Setting the Response Reading

1. Screw the regulator into the combustible gas calibration cylinder.
2. Connect the sample tubing from the demand flow regulator to the Model 1017-06S8's inlet line.
3. Allow the Model 1017-06S8 to draw sample for one minute.

4. Follow the directions in the controller's operator's manual for setting the span.
5. Disconnect the sample tubing from the inlet fitting.
6. Unscrew the regulator from the combustible gas calibration cylinder.

Returning to Normal Operation

1. Reconnect the incoming sample line.
2. Wait approximately one minute to allow the combustible gas reading to stabilize.
3. Follow the instructions in the controller's operator's manual to exit the calibration mode.
4. Store the components of the calibration kit in a safe and convenient place.

Parts List

Table 4 lists replacement parts and accessories for the Model 1017-06S8.

Table 2: Parts List

Part Number	Description
06-1200RK	Sample tubing, 4 x 6 mm, specify length (used for internal plumbing)
17-2595	Stainless steel tubing insert for 8 mm O.D. x 6 mm I.D. flexible tubing (used when flexible tubing is connected to inlet or exhaust fitting)
17-2665	Front ferrule (for inlet and exhaust fittings)
17-2666	Nut for ferrules
17-2667	Back ferrule (for inlet and exhaust fittings)
17-2668	Front and back ferrule set (for inlet and exhaust fittings)
30-1016RK	Pump, w/ cable and connector
33-3050RK	MC filter w/ cartridge & flow monitor (recommended for installation external to Model 1017-06S8 in inlet line)
81-0018RK-01	Calibration cylinder, 50% LEL isobutane in air, 34 liter
81-0018RK-03	Calibration cylinder, 50% LEL isobutane in air, 103 liter
81-0076RK-01	Zero air calibration cylinder, 34 liter
81-0076RK-03	Zero air calibration cylinder, 103 liter
81-1001RK	Dispensing valve (with knob)
81-1054RK	Regulator (demand flow)
81-1126RK	Gas collection bag (2 liter)
HW-6211	Combustible gas sensor, plug-in type, LEL